

## GENERAL MOTORS "H" BODY MODELS

**Buick**  
Skyhawk & Skyhawk S  
**Chevrolet**  
Monza & Monza Sport Coupe  
**Oldsmobile**  
Starfire  
**Pontiac**  
Sunbird & Sunbird Sport

### DESCRIPTION & OPERATION

Three instrument and gauge panels are used. A horizontal single piece speedometer and indicator warning light panel with an attached fuel gauge is standard on Monza and Sunbird. An optional six gauge (GT Cluster) is also available for Monza and Sunbird. A square instrument cluster with individual gauges is standard equipment on remaining "H" body models. Skyhawk has the same cluster design with the GT Cluster as an optional accessory. All gauges are removed from the front of the instrument panel

**Fuel Gauge** — Circuit consists of an electromagnetic gauge in instrument panel and a fuel tank sending unit incorporating a float, linkage, movable contact arm and a rheostat. As fuel level lowers, a balanced gauge pointer is moved by the changing resistance in the tank variable rheostat float mechanism. The decreasing resistance to gauge circuit allows gauge pointer to move towards the empty position. With ignition off, gauge pointer may rest anywhere. With ignition on, gauge pointer should indicate the correct fuel level.

**Temperature Indicator** — If equipped with an indicator light, engine temperature sending unit will close circuit to ground when temperature reaches about 258°F. When the ground circuit is completed, the indicator light will come on. If equipped with a gauge, the variable resistance type sending unit will allow more or less current to flow through gauge, thus varying the gauge reading.

**Oil Pressure Indicator** — Indicator light is actuated by a pressure operated sending unit. If oil pressure drops below a safe level, the sending unit will be allowed to close, completing the indicator light circuit to ground, turning on the light.

**Alternator Indicator** — Indicator light should come on with ignition on and engine not running. Light should go out after engine is started and accelerated above 900 RPM. Gauge should indicate a charge condition (plus side of gauge) whenever engine is running above an idle. Gauge may read a slight discharge at idle, and also when ignition is turned on and the engine is not running.

### TESTING

#### INDICATOR WARNING LIGHTS

**Temperature Indicator** — If "Hot" indicator light is inoperative when cranking engine, check for burned out light bulb, open in light circuit or a defective ignition switch. When light is on with engine running, check for coolant temperature above 258°F., short between light and switch, defective temperature or ignition switch.

**Oil Pressure Indicator** — Indicator light is inoperative with ignition switch on and engine not running. Check for burned out bulb, open light circuit or defective oil pressure switch. Indicator light is on and engine is running, indicates low oil pressure, defective oil pressure switch or short between light and switch.

**Charging System Indicator** — If light is inoperative with ignition in "On" position before starting engine, check for burned out bulb or short in wiring. If light is on with engine running, check for loose or missing belt, or short in the circuit. If good, check alternator (generator) and regulator for proper output.

#### FUEL GAUGE

Use a suitable Gas Gauge Tester (J-22344 or equivalent). Disconnect feed wire from the gas gauge tank terminal and connect one test lead to the wire and ground the other lead. Switch tester to "Empty" and "Full" positions and fuel gauge should read the same as the tester. If not, proceed with the following tests with ignition in "On" position.

**Gauge Never Reads Empty or Reads Full At All Times** — Check for disconnected or loose tank unit feed wire at tank. If good, check for proper connections at the printed circuit.

**Gauge Always Reads Empty** — Disconnect tank unit feed wire and gauge should indicate full. If not at "Full" position, check connections to printed circuit or for an open in the printed circuit.

**Gauge Never Reads Full** — Check system with Gas Gauge Tester, positioned in line between feed wire and tank terminal. If gauge reads full, fill the gas tank. Using an ohmmeter, check resistance of tank sending unit which should read between 88 and 92 ohms. If ohm reading is low, check tank mounting area for damage. If gauge does not read full, check connections to printed circuit or for an open within the printed circuit.

**Gauge Dead** — Check feed wire voltage to the tank which should read 3-4 volts. If it does not, check for open on hot side of the gauge, or proper connections at the printed circuit. If voltage is correct, remove and check fuel gauge.

#### OIL PRESSURE & TEMPERATURE GAUGE

Both gauges show actual readings and require a minimum of maintenance. The oil pressure gauge uses a direct tube from engine to gauge and if it becomes restricted, remove the tube at both ends and blow out the line. The temperature gauge is electric and uses a sending unit to transmit engine temperature. Do not repair either unit, replace the units when required.

#### AMMETER GAUGE

If gauge fails to read correctly, test charging system. See *Delco-Remy Alternators in ELECTRICAL Section for testing procedures.*

## GENERAL MOTORS "H" BODY MODELS (Cont.)

## STOP LIGHT SWITCH

If all stop lights fail to come on, or fail to turn off, check White wire terminal in turn signal connector using a test light, while depressing brake pedal. If test light fails to come on, check stop light switch adjustment. If adjustment is correct, replace stop light switch.

CLUTCH START SWITCH  
(MANUAL TRANSMISSION MODELS)

If engine will not start with clutch fully depressed, check switch for proper installation. If switch is properly installed, check switch circuit for an open or grounded condition. If circuit is good, replace clutch start switch. No adjustment is required.

## ADJUSTMENT

## STOP LIGHT SWITCH

With brake pedal fully depressed, push switch forward until it stops against pedal arm. Pull pedal rearward as far as possible to properly adjust switch. Stop lights should come on with brake pedal depressed  $\frac{3}{8}$ " to  $\frac{5}{8}$ ".

## REMOVAL &amp; INSTALLATION

## WINDSHIELD WIPER AND WASHER SWITCH

**Removal (Monza Sport Coupe & Sunbird Sport)** — Under instrument panel, remove the headlight switch multi-connector giving access to a wiper switch screw. Remove connector and seat belt buzzer (if equipped) from wiper switch. Remove mounting screws and wiper switch from behind the instrument panel.

**Installation** — To install, reverse removal procedure.

**Removal (All Models Exc. Monza Sport Coupe & Sunbird Sport)** — Disconnect ground cable from battery. Remove instrument panel insulator assembly and 2 screws securing switch and light shield. Remove 1 bottom screw and lower switch. Disconnect connector and remove switch.

**Installation** — To install, reverse removal procedure.

## HEADLIGHT SWITCH

**Removal (All Models)** — Disconnect ground cable at battery and pull switch control knob to "ON" position. Reach under instrument panel and depress switch control shaft knob. With a large blade screwdriver, remove light switch ferrule nut from front of instrument panel. Disconnect connector from side of switch, and remove switch.

**Installation** — To install, reverse removal procedure.

## INSTRUMENT PANEL PAD

**Removal (Monza & Sunbird)** — Remove screws from around edge of pad and on A/C equipped vehicles, disconnect left duct. Disengage clips and remove pad.

**Installation** — To install, reverse removal procedure.

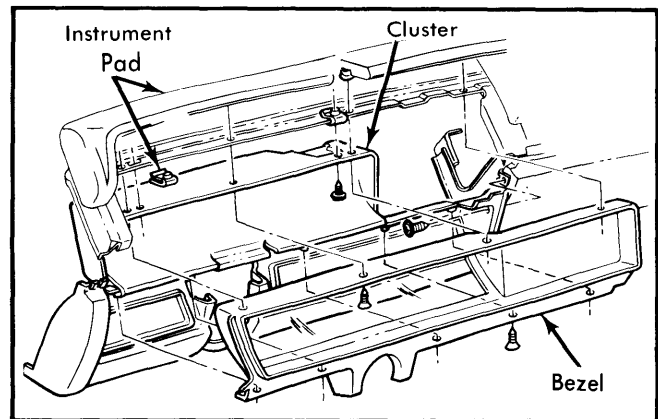

Fig. 1 Exploded View of Standard One Piece Instrument Panel Cluster — Monza and Sunbird

**Removal (Skyhawk & Starfire)** — 1) By removing 11 screws from around edge of pad, it is possible to remove pad without removing instrument cluster. Make sure A/C ducts are disconnected.

2) Disengage clips at rear of pad by prying up on pad. Remove pad.

**Installation** — To install, reverse removal procedure.

## INSTRUMENT CLUSTER &amp; GAUGES

**NOTE** — On all models, instruments, gauges and speedometer cable are removed from front of instrument cluster.

**Removal (Monza & Sunbird, Speedometer & Fuel Gauge)** — 1) Remove instrument cluster bezel, lens light shields, then tilt lens out at top. Lift and remove lens. Remove screws at bottom of speedometer face and remove speedometer. Disconnect speedometer cable.

2) To remove fuel gauge, remove 2 screws retaining gauge to cluster and using a small screwdriver release locking tab while rocking gauge. Pull gauge straight out and disconnect electrical lead.

**Installation** — To install, reverse removal procedure.

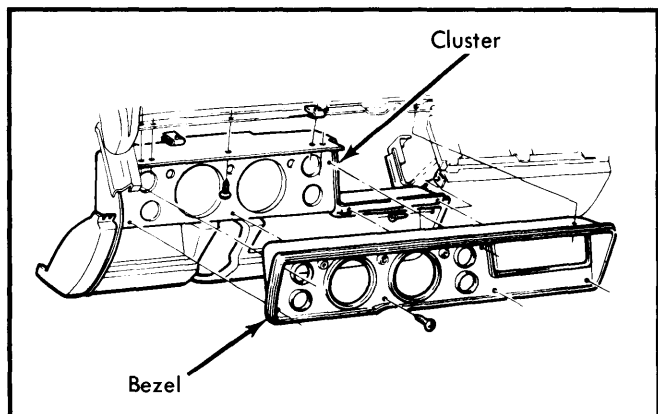

Fig. 2 Exploded View of GT Instrument Panel Cluster — Monza Sport Coupe and Sunbird Sport

## GENERAL MOTORS "H" BODY MODELS (Cont.)

**Removal (Monza & Sunbird, GT Cluster)** – Disconnect battery ground cable. Remove clock stem knob, cluster bezel and instrument panel pad. Remove 6 screws retaining light shield and lift shield straight out. Remove appropriate gauge retaining screws, pull gauge out, and disconnect electrical lead to gauge.

**Installation** – To install, reverse removal procedure.

### INSTRUMENT CLUSTER & GAUGES (ALL MODELS EXC. MONZA & SUNBIRD)

**Removal (All Gauges)** – Remove 4 screws retaining bezel and lens to instrument panel. Remove bezel and individual gauges from front of cluster. On Starfire, remove economy meter from back of cluster.

**NOTE** – Remove tachometer (if equipped) before removing fuel gauge.

**Installation** – To install, reverse removal procedure.

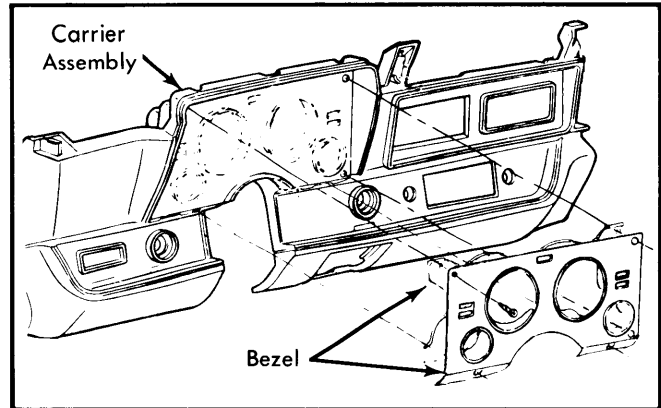

**Fig. 3 Exploded View of Instrument Panel Cluster – All Other "H" Body Models**