

## CHEVROLET

**Chevrolet**  
**All Models (Exc. Monza)**

**NOTE** — For Monza, see General Motors "H" Body in this section.

## DESCRIPTION &amp; OPERATION

**Fuel Gauge** — Circuit consists of an electrically operated indicator in instrument cluster and a float-type sending unit in fuel tank. Gauge pointer operation is controlled by the changing resistance in sending unit variable rheostat float mechanism.

**Oil & Temperature Indicator** — If oil pressure drops below a safe level or coolant temperature reaches 258°F, electrically operated sending units on engine will complete circuit to ground causing appropriate indicator light to come on.

**Oil Pressure & Temperature Gauge** — Both gauges show actual readings and require a minimum of maintenance. The oil pressure gauge uses a direct tube from engine to gauge and if it becomes restricted, remove the tube at both ends and blow out the line. The temperature gauge is electric and uses a sending unit to transmit engine temperature. Do not repair either unit, replace the units when required.

**Alternator Indicator** — Warning light circuit is designed to turn light on when ignition is on and engine is not running, or if a malfunction in the charging circuit occurs after engine has been started and accelerated above 900 RPM.

## TESTING

## FUEL GAUGE

Use suitable Gas Gauge Tester (J-22344 or equivalent). Disconnect feed wire from the gas tank terminal and connect 1 test lead to the wire and ground the other lead. Switch tester to "EMPTY" and "FULL" positions and fuel gauge should read the same as the tester. If not, proceed with the following tests with ignition in "ON" position.

**Gauge Never Reads Empty or Reads Full At All Times** — Check for disconnected or loose tank unit feed wire at tank. If good, check for proper connections at the printed circuit.

**Gauge Always Reads Empty** — Disconnect tank unit feed wire and gauge should indicate full. If not at "FULL" position, check connections to printed circuit or for an open in the printed circuit.

**Gauge Never Reads Full** — Check system with Gas Gauge Tester, positioned in line between feed wire and tank terminal. If gauge reads full, fill the gas tank. Using an ohmmeter, check resistance of tank sending unit which should read between 88 and 92 ohms. If ohm reading is low, check tank mounting area for damage. If gauge does not read full, check connections to printed circuit or for an open within the printed circuit.

**Gauge Dead** — Check feed wire voltage to the tank which should read 3-4 volts. If it does not, check for open on hot side of the gauge, or proper connections at the printed circuit. If voltage is correct, remove and check fuel gauge.

## INDICATOR WARNING LIGHTS

**Oil Pressure** — If light does not come on with ignition on and engine not running, check for burned out bulb, light circuit open, or defective sending unit. If light remains on when engine is running above idle speed, check for grounded wire between bulb and sending unit, defective sending unit, or low oil pressure.

**Coolant Temperature** — If "HOT" indicator fails to light when cranking engine, check for burned out bulb, open light circuit, or defective ignition switch. If indicator light remains on with engine running, check for ground in wire between bulb and sending unit, a defective sending unit or ignition switch, or excessive coolant temperature.

**Alternator Indicator** — If light remains on when ignition is off, check for shorted alternator positive diode. If light remains off when ignition is on, but the engine is not running, check for burned out indicator bulb, an open light circuit, or an open in alternator field. If light comes on with engine running above idle RPM, check alternator output, check for a shorted alternator negative diode or loose or broken alternator belt.

## STOP LIGHT SWITCH

If all stop lights fail to come on, or fail to turn off, check White wire terminal in steering column connector with test light. If test light does not come on, check switch for proper adjustment. If adjusted correctly, replace stop light switch.

## REMOVAL &amp; INSTALLATION

## STOP LIGHT SWITCH

**Removal** — Disconnect wiring harness from switch, remove switch retaining nut (if equipped), and unscrew switch from bracket.

**Installation** — To install, reverse removal procedure and adjust.

## CLUTCH START SWITCH

Vehicles with manual transmissions use a clutch start switch which prevents engine start unless the clutch pedal is depressed. The switch mounts on clutch pedal bracket.

**Removal (All Models Exc. Corvette)** — To remove switch, unplug electrical connector from switch, compress actuating shaft retainer and disconnect shaft from clutch pedal. Remove switch and/or bracket for service as required.

**Installation** — To install, reverse removal procedure, no adjustment necessary.

**Removal (Corvette)** — To remove switch unplug electrical connector from switch. Remove retainer from link on clutch arm. Remove screw fastening switch to pedal support and lift off switch.

**Installation** — To install, reverse removal procedure.

## CHEVROLET (Cont.)

### WINDSHIELD WIPER/WASHER SWITCH

**Removal (Chevrolet)** — Disconnect ground cable from battery. Remove screw and the control shroud (1 screw is hidden above headlight switch shaft and 1 screw is above the cigar lighter knob). Remove wiper switch from harness.

**Installation** — To install, reverse removal procedure.

**Removal (El Camino, Caballero, Malibu & Monte Carlo)** — Disconnect battery ground cable. Remove instrument panel bezel and screws securing switch to cluster assembly plate. Disconnect wiper switch from harness, remove bulb assembly from switch, then remove switch.

**Installation** — To install, reverse removal procedure.

**Removal (Nova)** — Disconnect battery. Remove connector and bulb at rear of switch. Remove 2 screws and switch.

**Installation** — To install, reverse removal procedure.

**Removal (Camaro)** — Remove trim plate, A/C lap cooler outlet and light switch. Remove connector from wiper switch, tilt carrier and remove screws and switch.

**Installation** — To install, reverse removal procedure and insure that all ground wire or straps are secure.

**Removal (Corvette) — 1** Disconnect battery ground cable. Remove left A/C duct, instrument panel-to-instrument cluster attaching screws and pull cluster rearward for access.

**2** Disconnect speedometer cable and electrical connector from cluster, then remove cluster.

**3** Remove screws attaching left door pillar-to instrument panel and pull left side of instrument panel rearward for access.

**4** Remove wiper switch mounting plate screws, then remove switch.

**Installation** — To install, reverse removal procedure.

**Removal (Chevette)** — Wiper/washer switch is located on left side of the steering column under the directional signal switch. Remove steering wheel and directional signal switch. Remove upper attaching screw on the ignition and dimmer switch, releasing the dimmer switch and actuating lever.

**NOTE** — Do not move the ignition switch.

Remove the wiper/washer switch and pivot assembly from the column housing.

**Installation** — To install, reverse removal procedure.

### HEADLIGHT SWITCH

**Removal (Chevrolet, Chevette & Nova)** — Disconnect battery. Place control knob in "ON" position. From under instrument panel release switch shaft retainer, pull knob and shaft assembly out. Remove ferrule nut and lift out switch assembly. Disconnect plug from light switch.

**Installation** — To install, reverse removal procedure.

**Removal (Malibu & Monte Carlo)** — Disconnect battery. Remove instrument panel pad. Remove left radio speaker and pull switch control knob to "ON" position. From behind instrument panel, release switch shaft retainer and remove shaft assembly. Remove ferrule nut and lift out switch assembly.

**Installation** — To install, reverse removal procedure.

**Removal (Camaro)** — Disconnect battery. Remove steering column lower cover. Reach up under panel and depress switch shaft retainer, while pulling on shaft. Remove nut securing switch to carrier. Remove cluster carrier, 4 screws in front, 2 screws from back of cluster lower edge (either side of steering column) and tilt right side of cluster out. Unplug connector from lighting switch and remove switch.

**Installation** — To install, reverse removal procedure and make sure all ground connections are refastened.

**Removal (Corvette) — 1** Disconnect battery. Remove screws securing mast jacket trim covers, remove covers for access. Unclip and remove left side console forward trim panel so that left side instrument cluster may be lowered for access to switch. Lower steering column.

**2** Remove screws and washers securing left instrument panel-to-door opening, top of dash and left side of center instrument panel. Pull cluster assembly down and then tip forward for access to switch. Depress switch shaft retainer and remove knob and shaft assembly.

**3** Remove switch retaining bezel. Disconnect vacuum hoses from switch (mark for reassembly). Pry connector from switch and remove switch.

**Installation** — To install, reverse removal procedure.

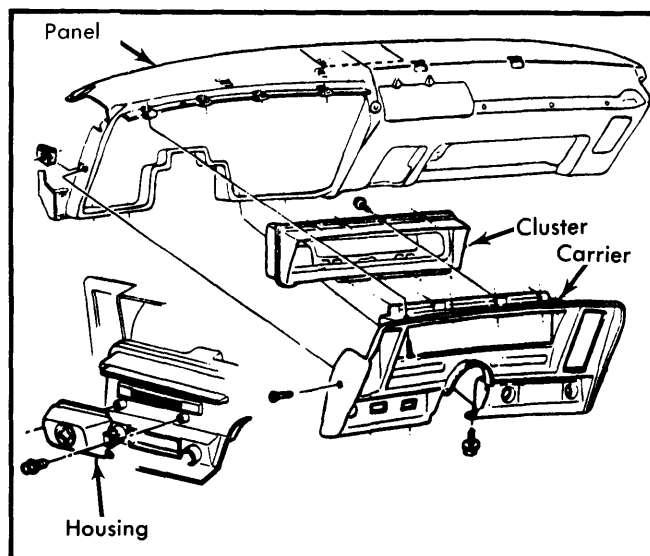

Fig. 1 Nova Instrument Cluster

## CHEVROLET (Cont.)

## INSTRUMENT CLUSTER

**Removal (Nova) — 1)** Disconnect battery. Lower steering column. Remove screws above front of heater control securing it to cluster. Remove radio control knobs, washers, bezel nuts and front support at lower edge of cluster (allows radio to remain in panel).

**2)** Remove screws at top, bottom and sides of cluster. Tilt console forward and reach behind to disconnect speedometer cable, speedminder and electrical plug connectors. After removing screws, lift cluster out of carrier.

**Installation —** To install, reverse removal procedure using caution not to kink cable housing.

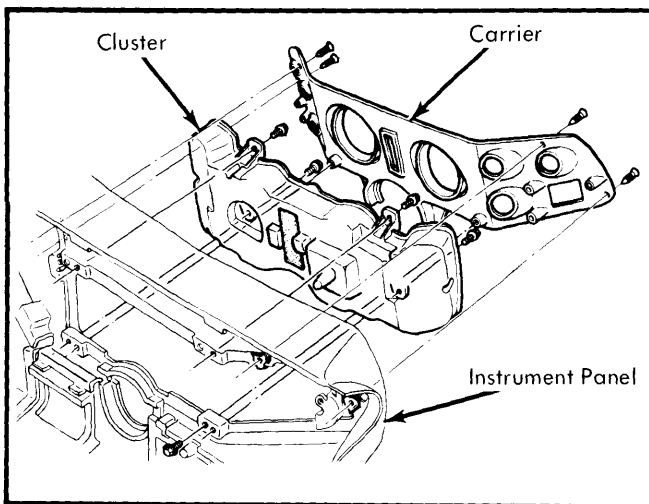

**Fig. 2 Camaro Instrument Cluster Assembly**

**Removal (Camaro) — 1)** Disconnect battery. Remove screws (2 above ash tray) securing trim cover beneath steering column. Reach under cluster left side and depress headlight switch shaft retainer button, while pulling on switch knob. Remove headlight switch retaining nut, cigar lighter and housing.

**2)** From rear of panel remove screw on either side of steering column. Remove 4 screws on front of carrier and 1 screw retaining ground wire for wiper switch. Tilt carrier out (for access) and remove connector plugs on wiper and headlight switches.

**3)** Remove 8 screws securing cluster lens and 4 screws securing cluster. Disconnect PRNDL indicator from steering column.

**4)** Reach behind cluster, depress speedometer cable housing tang on rear of cluster then tilt cluster forward.

**5)** Remove connectors from printed circuit and clock, then free harness from retainer clips and remove cluster.

**Installation —** To install, reverse removal procedure.

**Removal (Chevrolet) — 1)** Disconnect battery ground cable. Remove 4 screws from lower steering column cover and remove cover. If vehicle is equipped with automatic transmission, disconnect shift indicator cable from steering column. Remove 2 screws between steering column and instrument panel.

**2)** Remove remaining screws from front surface, disconnect speedometer cable and pull cluster outward.

**Installation —** To install, reverse removal procedure.

**Removal (Malibu) — 1)** Disconnect battery. Remove radio and clock stem knobs. Remove instrument bezel retaining screws. Pull bezel out and disconnect tailgate release, (Station Wagon), or defogger switch.

**2)** Remove retaining screws to speedometer head and lift head out. Remove clock mounting screws and lift out clock. Disconnect transmission shift indicator cable from steering column. Disconnect wiring and speedometer cable.

**3)** Remove instrument cluster case, fuel gauge and transmission shift indicator and cluster.

**Installation —** To install, reverse removal procedure.

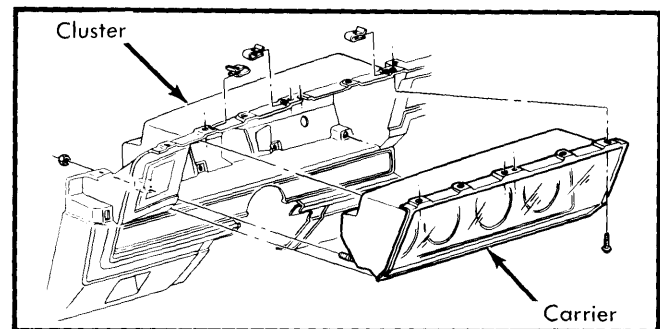

**Fig. 3 Chevrolet Instrument Cluster**

**Removal (Monte Carlo) —** Disconnect battery ground. Remove radio knobs and clock set knob. Remove instrument bezel retaining screws and pull bezel out. Disconnect transmission shift cable (if equipped). Remove speedometer retaining screws and speedometer. Remove cluster and gauges for service as required.

**Installation —** To install, reverse removal procedure.

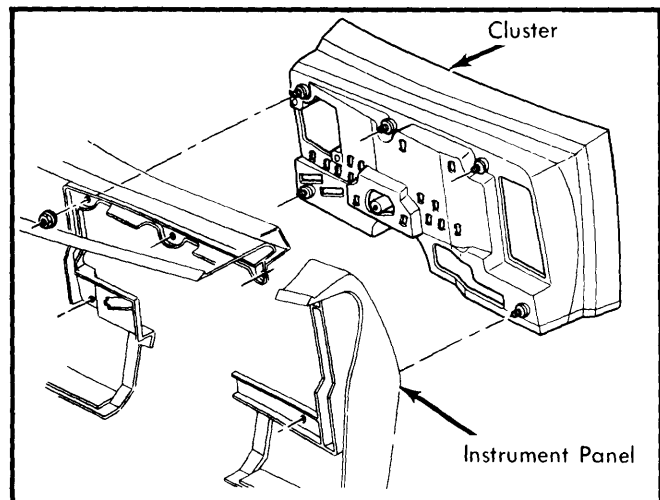

**Fig. 4 Malibu and Monte Carlo Instrument Cluster Assembly**

## CHEVROLET (Cont.)

**Removal (Corvette Left Side)** – 1) Disconnect battery. Lower steering column. Remove screws and washers securing left instrument panel to door opening, top of dash and left side of center instrument panel.

2) Unclip and remove floor console left forward from panel. Pull cluster assembly slightly forward (for access). Remove speedometer cable housing nut, tachometer cable housing nut, headlight and ignition switch connectors and instrument lights. Remove cluster.

**Installation** – To install, reverse removal procedure.

**Removal (Corvette Center Section)** – 1) Disconnect battery. Remove wiper switch trim plate screws, tip plate forward and remove connector. Lift trim plate out from cluster assembly. Unclip and remove right and left console forward trim pads.

2) Remove nuts from studs at lower edge of cluster. Remove remaining screws retaining cluster assembly to instrument panel. Remove right instrument panel pad.

3) Remove radio knobs, bezel retaining nuts and 1 radio support bolt (behind cluster assembly). Slide radio back towards firewall and pull cluster forward. Reach behind cluster, disconnect oil pressure line, wiring harness and bulbs.

**CAUTION** – Center cluster trim plate is designed to collapse under impact.

4) Lift cluster assembly up and forward for removal.

**Installation** – To install, reverse removal procedure.

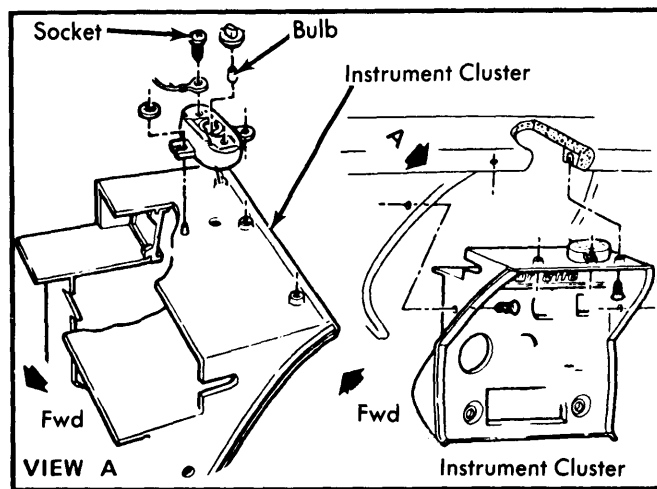

Fig. 5 Corvette Instrument Cluster

**Removal (Chevette)** – Disconnect battery ground cable. Remove clock stem knob and 4 screws retaining cluster bezel and lens. Remove 2 nuts retaining cluster to panel, pull cluster outward, disconnect electrical connectors and speedometer cable, then remove cluster.

**Installation** – To install, reverse removal procedure.

### GAUGES & SPEEDOMETERS

**Removal (Nova Fuel Gauge)** – Disconnect negative battery cable. Reach behind cluster and remove cluster lights and

gauge wiring terminal nuts. Move printed circuit away from gauge and remove screws retaining gauge to cluster. Remove gauge assembly from housing and separate gauge from cover plate.

**Installation** – To install, reverse removal procedure.

**Removal (Nova Speedometer)** – With instrument cluster removed, separate rear cover from cluster assembly by removing retaining screws and bending ground strap away. Remove screws retaining speedometer and remove speedometer from rear cover.

**Installation** – To install, reverse removal procedure.

**Removal (Camaro)** – Remove instrument cluster, screws retaining speedometer to cluster or nuts retaining gauge to printed circuit.

**Installation** – To install, reverse removal procedure.

**Removal (Chevrolet)** – Remove instrument cluster shroud, screws retaining gauge or speedometer and electrical or cable connections to gauge.

**Installation** – To install, reverse removal procedure.

**Removal (Malibu & Monte Carlo)** – Remove instrument panel bezel, screws retaining gauge or speedometer, and electrical or cable connections to gauge.

**Installation** – To install, reverse removal procedure.

**Removal (Corvette Speedometer or Tachometer)** – Remove left cluster assembly, odometer reset and speedometer connectors from rear of speedometer head, and retaining screws securing speedometer or tachometer to back of cluster.

**Installation** – To install, reverse removal procedure.

**Removal (Corvette All Other Gauges)** – Remove center instrument cluster, then remove screws retaining appropriate gauge to cluster housing.

**Installation** – To install, reverse removal procedure.

**Removal (Chevette)** – Remove instrument cluster as previously described, then remove screws retaining appropriate gauge and remove gauge from cluster.

**Installation** – To install, reverse removal procedure.

### PRINTED CIRCUITS

**Removal (Nova)** – Remove instrument cluster and illumination and indicator lights. Remove fuel gauge and clock terminal nuts retaining printed circuit to housing. Remove 4 screws retaining printed circuit to cluster housing and remove printed circuit.

**Installation** – To install, reverse removal procedure.

**Removal (Camaro, Chevette, Malibu & Monte Carlo)** – Remove instrument cluster, lights, light sockets, mounting slugs and printed circuit.

**Installation** – To install, reverse removal procedure.