

FORD MOTOR CO.

Ford Motor Co.

DESCRIPTION

Speed control system consists of an "ON-OFF" switch, a "SET-ACCEL" and "COAST" switch, a "RESUME" switch (Ford, Mercury, Fairmont, Zephyr, Mustang and Capri only), a servo assembly, a speed sensor, a vacuum dump valve (Ford, Mercury, Fairmont, Zephyr, Mustang and Capri only), an amplifier, a vacuum reservoir (all exc. Ford, Mercury, Fairmont, Zephyr, Mustang and Capri), a wiring harness and vacuum hoses to connect components.

The switches are located in steering wheel spokes. Servo assembly and vacuum reservoir (if equipped) are located in engine compartment. Amplifier assembly is located under instrument panel. Speed sensor is located in engine compartment on Continental Mark V, Lincoln Continental, Fairmont, Zephyr, Mustang and Capri and in passenger compartment on all other models.

OPERATION

This system is operational at speeds above 30 MPH. When the "ON - OFF" switch is set to the "ON" position and the driver depresses and releases the "SET - ACC" button, the vehicle speed will be maintained until a new speed is set by the driver, until the brake pedal is depressed, or until the system is turned off. On Ford, Mercury, Fairmont, Zephyr, Mustang and Capri, if system is deactivated by depressing brake or clutch pedal, driver may re-establish set speed by depressing and releasing "RESUME" switch.

TESTING

CONTROL SWITCHES

1) Disconnect six-way connector at amplifier assembly. Connect voltmeter between Lt. Blue-Black lead and ground. Depress "ON" button and check for battery voltage with ignition switch on. Turn ignition off.

2) Connect ohmmeter between Lt. Blue-Black lead and ground. Rotate steering wheel and make the following tests:

Depress "OFF" button and check for a reading between zero and one ohm.

Depress "SET" button and check for a reading of 646 to 714 ohms.

Depress "COAST" button and check for a reading of 114 to 126 ohms.

Depress "RESUME" button (if equipped) and check for a reading of 2090 to 2310 ohms.

If resistance values are okay but meter needle fluctuates, remove steering wheel and clean contact surfaces of speed control ground brush and turn signal brush. If resistance readings are high, check switch assemblies and ground circuit in steering column.

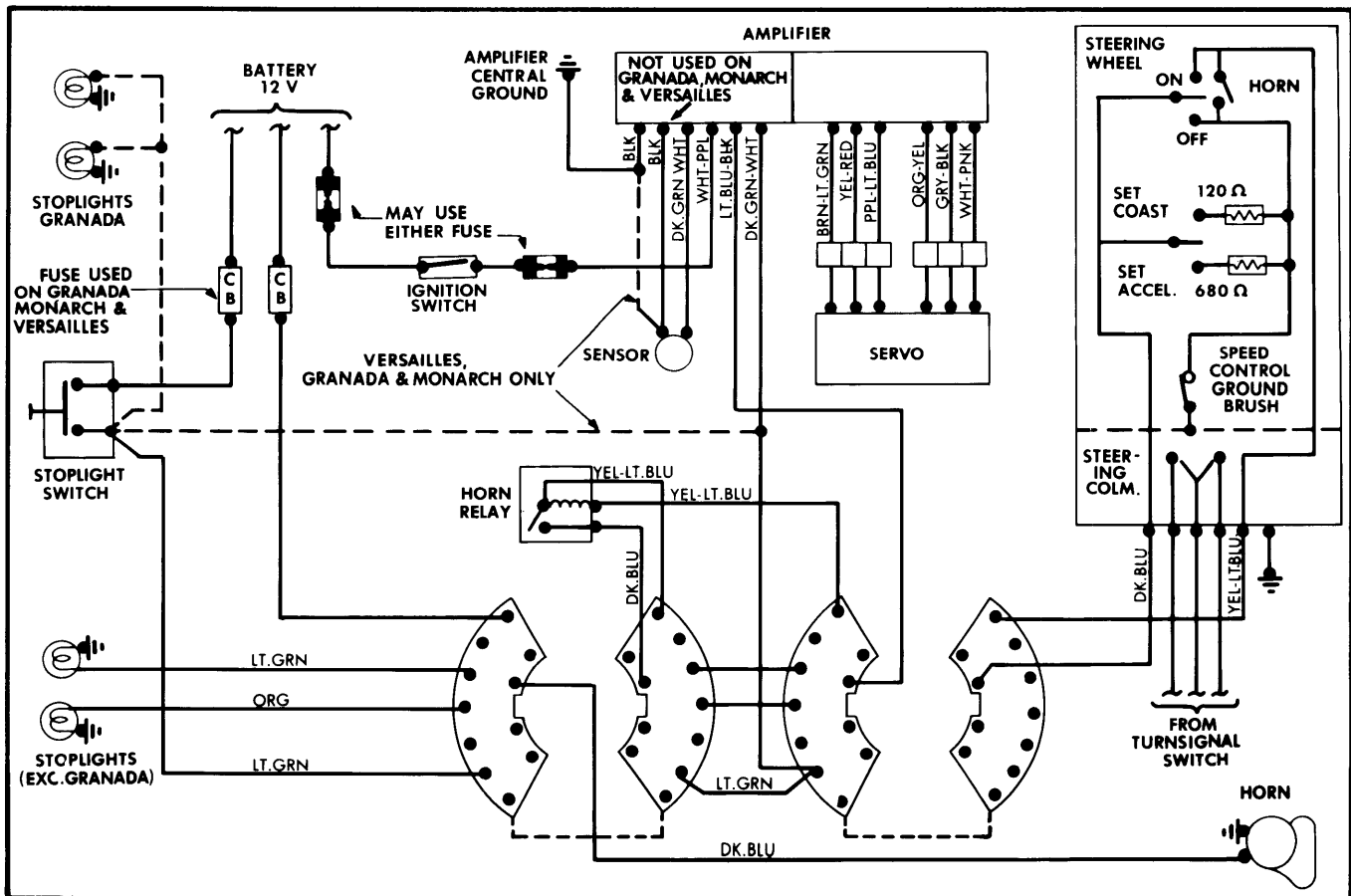

Fig. 1 Wiring Diagram for Ford Motor Co. Automatic Speed Control System (All Except Ford, Mercury, Fairmont, Zephyr, Mustang and Capri)

FORD MOTOR CO. (Cont.)

SPEED SENSOR

Disconnect connector containing speed sensor wires from amplifier and connect an ohmmeter between wire connector terminals (green/white stripe and black) at speed sensor end. A reading of about 40 ohms should be obtained. A reading of 0 ohms indicates a shorted coil and a maximum reading indicates an open coil. Replace sensor in either case. If reading is 40 ohms and speedometer operates properly, speed sensor is probably good. A new sensor should be substituted in place of old sensor to check for proper operation.

SERVO ASSEMBLY

CAUTION — If Orange-Yellow lead is shorted to either White-Pink or Grey-Black leads it may be necessary to replace the amplifier.

1) Disconnect ball chain from throttle linkage. Separate servo-to-amplifier connector. Connect an ohmmeter between Orange-Yellow and Grey-Black wires at servo connector. Resistance should be approximately 85 ohms.

2) Connect ohmmeter between Orange-Yellow and White-Pink wire leads. Resistance should be approximately 85 ohms. Reconnect ball chain.

3) Start engine. Jumper Orange-Yellow lead of servo connector to battery positive post and White-Pink lead of servo connector to ground. Momentarily touch Grey-Black lead of servo connector to ground. Servo throttle actuator should tighten bead chain to open throttle. Throttle should hold in that position, or slowly release chain tension. If White-Pink wire is removed from ground, servo should immediately release tension on chain.

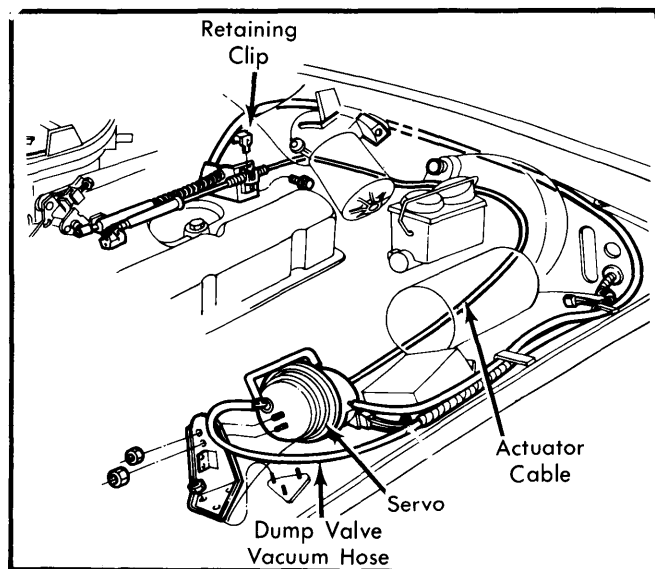

Fig. 2 Engine Compartment Speed Control Components for Ford and Mercury Models (All Fairmont, Zephyr, Mustang and Capri, Except 302" Engine Models, are Similar)

AMPLIFIER

CAUTION — DO NOT use a test light to perform amplifier tests because too much current draw will damage electronic components. Use only a voltmeter of 5000 ohm/volt rating or higher.

Make the following tests at the amplifier six-way harness connector.

"ON" Circuit Test — 1) Turn ignition on and connect voltmeter to Lt. Blue-Black wire and ground. Depress and hold "ON" switch in steering wheel. Meter should read 12 volts. If voltage is not available, check horn relay circuit and perform Control Switch Test.

2) Release the "ON" switch. Voltmeter should now read approximately 7.8 volts on Ford, Mercury, Fairmont, Zephyr, Mustang and Capri, 12 volts on all other models. If voltage is incorrect, check for good ground on amplifier, blown fuse and/or circuit breaker. Install a known good amplifier and recheck "ON" circuit if necessary.

"OFF" Circuit Test — Turn ignition on and connect voltmeter to Lt. Blue-Black wire and ground. Depress "OFF" switch in steering wheel. Voltage should drop to zero when switch is depressed showing that the "ON" circuit has been turned off. If voltage does not drop, perform Control Switch Test. If "OFF" circuit test okay, install a known good amplifier and retest.

"SET-ACCELERATE" Circuit Test — Turn ignition on and connect voltmeter to Lt. Blue-Black wire and ground. Depress "ON" button on steering wheel then hold down on "SET-ACCEL" button. Voltmeter should read approximately 4.5 volts on Ford, Mercury, Fairmont, Zephyr, Mustang and Capri, 10 volts on all other models. Rotate steering wheel and watch voltmeter for variation. If voltage varies more than 0.5 volt, perform Control Switch Test.

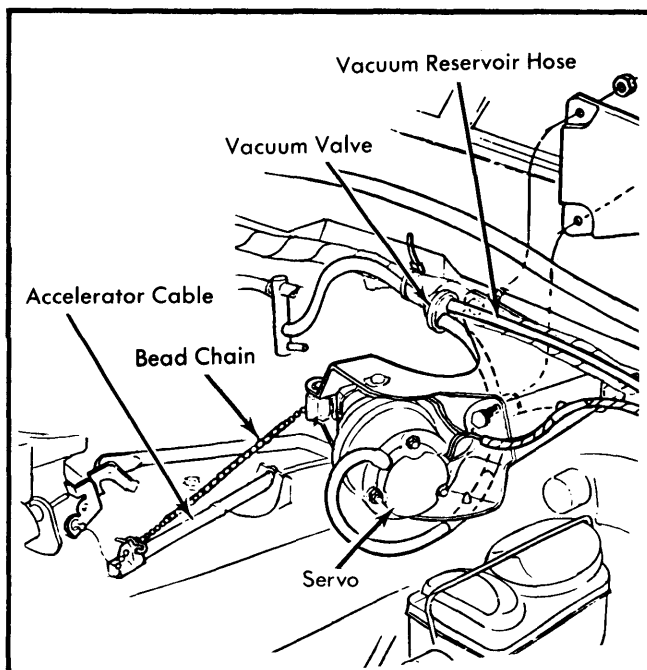

Fig. 3 Engine Compartment Speed Control Components for Cougar, LTD II, Ranchero and Thunderbird with 351" and 400" Engines

FORD MOTOR CO. (Cont.)

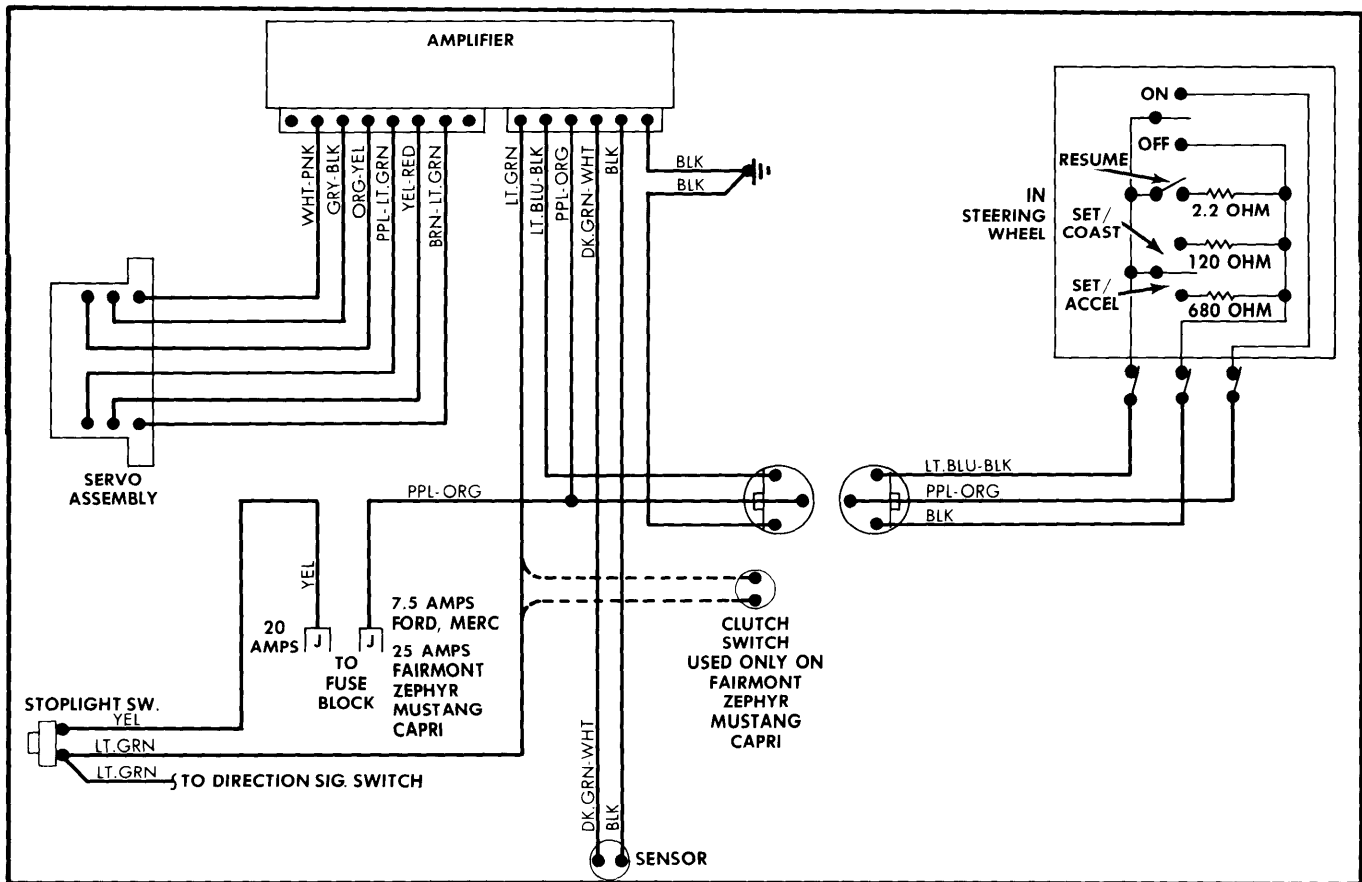

Fig. 4 Wiring Diagram for Ford Motor Co. Automatic Speed Control System (Ford, Mercury, Fairmont, Zephyr, Mustang and Capri)

"COAST" Circuit Test — Turn ignition on and connect voltmeter to Lt. Blue-Black wire and ground. Depress "ON" switch in steering wheel and hold down on "COAST" button. Voltmeter should read approximately 1.5 volts on Ford, Mercury, Fairmont, Zephyr, Mustang and Capri, 6 volts on all other models. If all functions check good, perform Servo Test and Sensor Test, and install a known good amplifier and recheck.

CAUTION — Do not substitute a new amplifier until actuator coils have been tested as described in Servo Assembly Tests.

"RESUME" Circuit Test (If So Equipped) — Turn ignition on and connect voltmeter to Lt. Blue-Black wire and ground. Depress "RESUME" button on steering wheel. Voltmeter should read approximately 6.5 volts. If function checks good, perform Servo Test, and install a known good amplifier and recheck.

VACUUM DUMP VALVE (IF SO EQUIPPED)

Vacuum dump valve is a redundant safety feature which releases servo vacuum whenever brake pedal is depressed. To test, disconnect dump valve vacuum hose at servo, connect hand vacuum pump to hose and apply vacuum. If vacuum will not hold, hose or dump valve leaks and should be replaced or adjusted. Step on brake pedal. If vacuum is not released, adjust or replace dump valve.

ADJUSTMENTS

LINKAGE

Bead Chain Type — On Fairmont, Zephyr, Mustang and Capri, adjust bead chain so chain is tight when engine is at hot idle speed. On all other models, adjust chain to obtain 1/8-1/4" actuator arm free travel at hot idle speed. On vehicles with solenoid throttle positioner, turn ignition "ON" and open throttle slightly before performing adjustment.

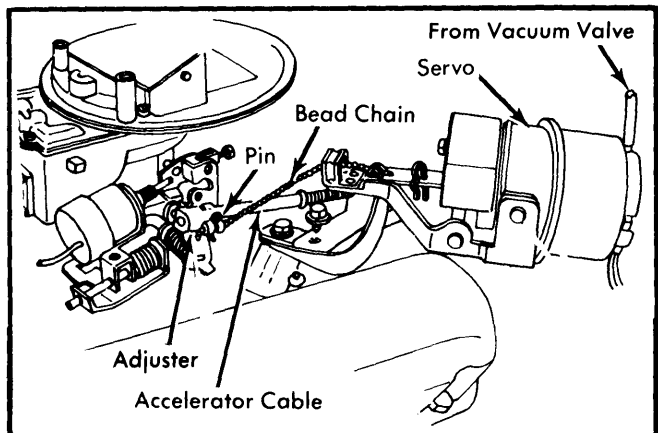

Fig. 5 Engine Compartment Speed Control Components for Versailles and Granada, Monarch V8 (All Models with 302" Engine are Similar)

Speed Control Systems — Automatic 5-57

FORD MOTOR CO. (Cont.)

Actuator Cable Type — Disengage throttle positioner and set carburetor at hot idle speed. Remove cable retaining clip, pull on actuator cable to take up any slack and insert cable retaining clip.

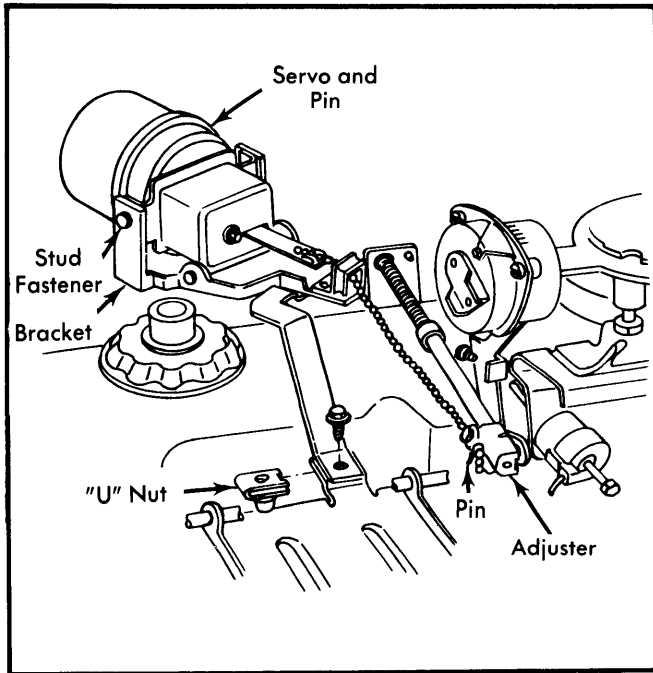

Fig. 6 Engine Compartment Speed Control Components for Continental Mark V (Lincoln Continental is Similar)

VACUUM DUMP VALVE (IF SO EQUIPPED)

Adjust dump valve (located at brake pedal) by moving it in its mounting bracket so there is no vacuum leak when brake pedal is in non-depressed position and vacuum leak when pedal is depressed. Apply vacuum with hand vacuum pump.

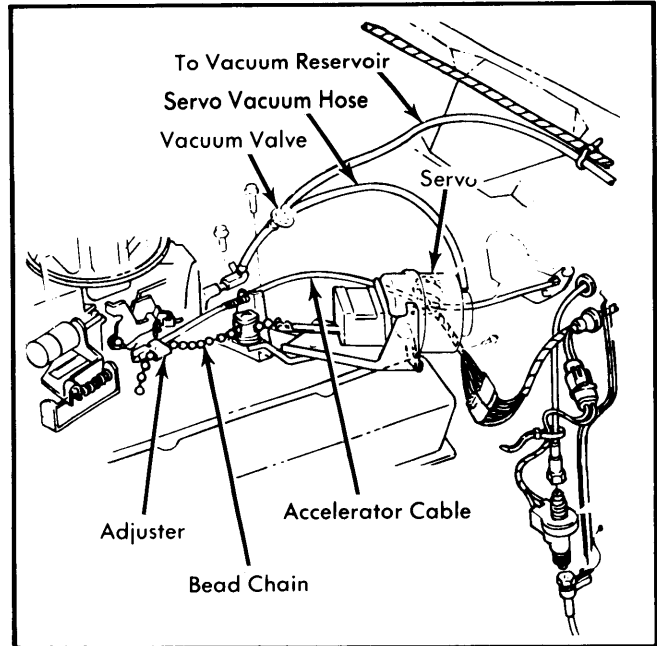

Fig. 7 Engine Compartment Speed Control Components for Granada and Monarch Six Cylinder Engine