

AMERICAN MOTORS CRUISE COMMAND

American Motors

DESCRIPTION

System senses car speed through speedometer cable and uses engine intake manifold vacuum to regulate accelerator and to automatically maintain any pre-set cruising speed above 30 MPH as selected by the driver.

OPERATION

Cruise Command control is an integral part of the directional switch lever and consists of two separate switches. The first is "OFF-ON" and "RES" (resume) slide switch located on the flat of the directional control lever. Second is a push button "SET" switch on the end of the lever. To engage system, move slide switch to "ON" position, accelerate to desired speed (at least 30 MPH) and depress and release "SET" button. System will now maintain speed until brake pedal is depressed or slide switch is moved to "OFF" position. If disengaged by brake pedal, system may be re-engaged to previously selected speed by accelerating to 30 MPH and moving slide switch to "RES" position, then releasing switch.

NOTE — "OFF" position erases memory and cancels pre-set speed of "RES" function.

A higher speed can be set by pressing on accelerator until new speed is reached, then press and release "SET" button. A lower speed can be achieved by depressing "SET" button until car slows to desired speed, then releasing button to maintain new speed. Individual components operate as follows:

Sensor — The electronic speed sensor is installed between the upper and lower speedometer cables and provides electrical signals to the regulator.

Regulator — The regulator prevents operation below 30 MPH and supplies electrical signals to the vacuum operated servo which controls the throttle position. Regulator is suspended from the instrument panel harness by straps on Pacer and is mounted on a bracket behind the headlight switch on Spirit, AMX and Concord. Service is limited to centering adjustment.

Release System — The release system de-energizes Cruise Command in two ways. By depressing the brake pedal, an electrical signal is sent through the regulator to the servo where the vacuum supply valve closes and the dump valve opens.

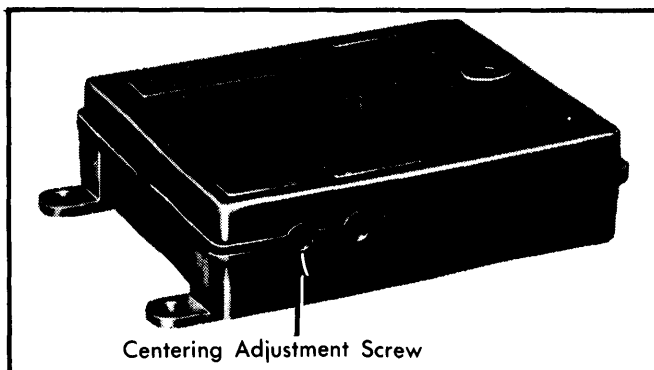

Fig. 1 Regulator Showing Centering Adjustment

A mechanical dump valve operated by the brake pedal admits atmospheric pressure into the servo ensuring immediate servo release. Pushing the slide switch to "OFF" position also deactivates Cruise Command.

TROUBLE SHOOTING & DIAGNOSIS

SYSTEM WILL NOT ENGAGE IN "ON" POSITION — Restricted or no vacuum. Control switch, regulator or speed sensor defective.

RESUME FEATURE INOPERATIVE — Bad ground to servo.

SYSTEM RE-ENGAGES WHEN BRAKE RELEASED — Defective regulator, dump valve not opening or kink in dump valve hose.

DOES NOT RETURN TO IDLE — Improper linkage or chain adjustment.

ROAD SPEED CHANGES MORE THAN 2 MPH WHEN SETTING SPEED — Centering adjustment on regulator set wrong.

ENGINE ACCELERATES WHEN STARTED — No slack in bead chain. Vacuum hoses reversed. Defective servo.

DISENGAGES ON LEVEL ROAD WITHOUT APPLYING BRAKE — Loose wiring connection, loose vacuum connection. Servo linkage broken. Defective stop light switch.

ERRATIC OPERATION — Speed sensor wires reversed. Defective servo or regulator.

VEHICLE CONTINUES TO ACCELERATE WHEN PUSH BUTTON RELEASED — Defective servo or regulator.

SYSTEM ENGAGES BUT LOSES SET SPEED SLOWLY — Vacuum leak at brake pedal dump valve.

TESTING

The following diagnostic tests determine the cause of the malfunction and corrective steps required.

CONTROL SWITCH CONTINUITY

Using a 12-volt test lamp with 12-volt feed applied to the RED terminal of the control switch, check control switch continuity.

Control Switch Continuity Conditions

Application	Switch Position	Condition
Red-to-Brown	"OFF"	Open
Red-to-Green	"OFF"	Open
Red-to-Yellow	"OFF"	Open
Red-to-Brown	"ON"	Closed
Red-to-Green	"ON"	Closed
Red-to-Yellow	"ON"	Open
Red-to-Brown	"RES"	Closed
Red-to-Green	"RES"	Closed
Red-to-Yellow	"RES"	Closed
Red-to-Brown	"ON"⓪	Closed
Red-to-Green	"ON"⓪	Open
Red-to-Yellow	"ON"⓪	Closed

⓪ — Pushbutton depressed.

AMERICAN MOTORS CRUISE COMMAND (Cont.)

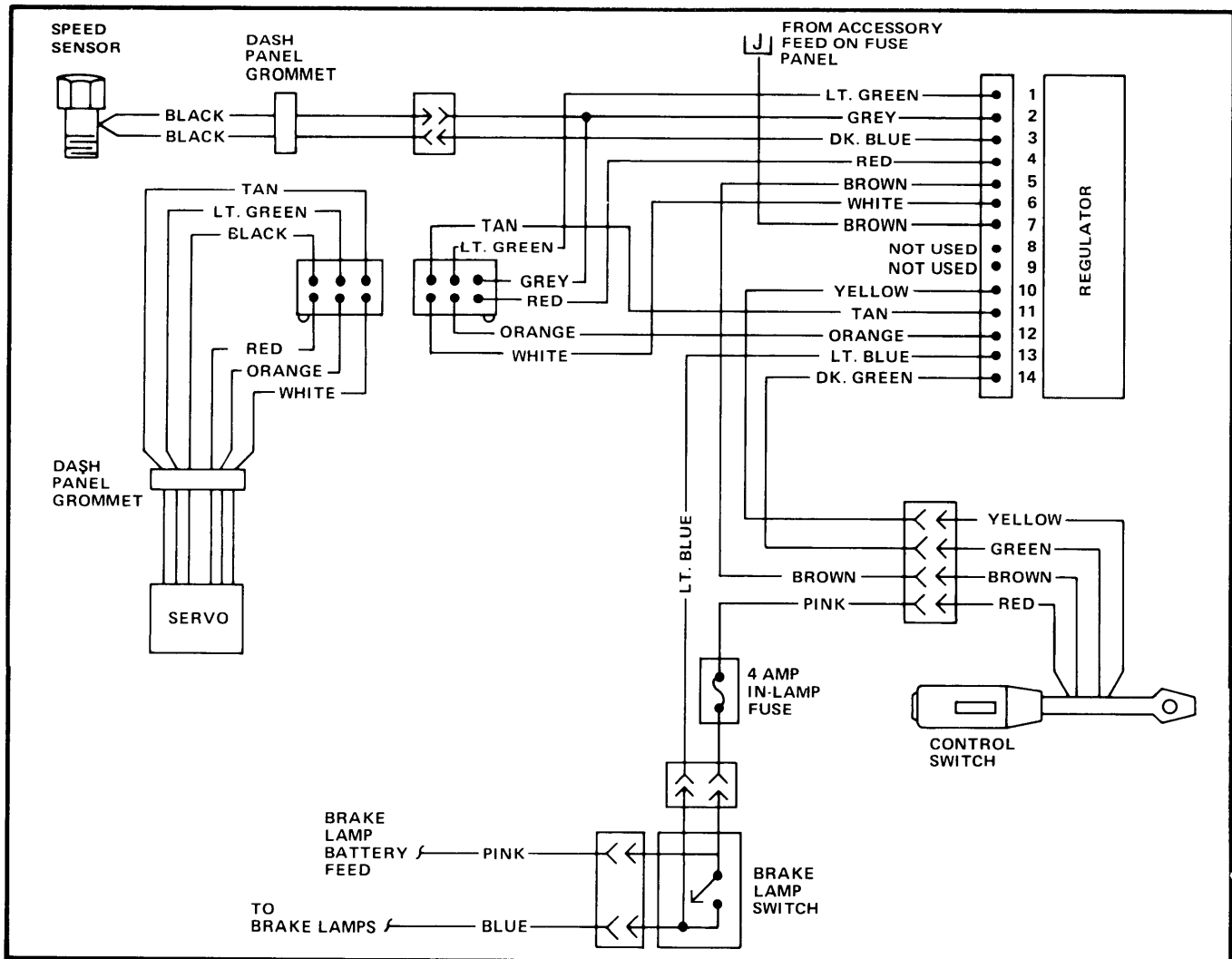

Fig. 2 Cruise Command Schematic

CIRCUITRY TESTS

Using test lamp, check following terminals of regulator connector. See Fig. 2. Verify each terminal is installed in correct location.

Switch OFF—Key OFF – Should have NO light at all terminals.

- If light at 14, 10 or 5, check control switch.
- If light at 13, reverse pink and blue wire connection at brake light switch.
- If light at 7, wire is connected to wrong fuse. Connect to accessory fuse.

Switch OFF – Key ON – Should light at 7.

- If no light at 7, check accessory fuse and connections.

Switch ON – Key ON – Light at 5, 7 and 14.

- If no light at 5 and 14, check control switch.
- If no light at 7, check accessory fuse and connection.

Switch ON – Key OFF – Light at 5 and 14.

- If no light, check control switch.

Switch in RES – Key OFF – Light at 5, 10 and 14.

- If light at 10 does NOT go out when RES released, replace control switch.

SET button depressed – Key OFF – Should light at 5 and 10, go out at 10 when SET released.

- If not, verify wire positions.
- If correct, check control switch.

Brake pedal depressed – Should light at 13.

- If no light, check for loose connector at brake switch, blown fuse or defective brake switch.

ADJUSTMENTS

CENTERING ADJUSTMENT

Adjustment is made by turning centering adjustment screw on regulator. See Fig. 1.

1) Turn screw counter-clockwise a small amount if speed control engages at two or more MPH higher than selected speed.

2) Turn screw clockwise a small amount if speed control engages at two or more MPH below selected speed.

NOTE – Check for proper centering on level road after each adjustment.

VACUUM DUMP VALVE

To adjust dump valve, depress brake pedal and move valve toward bracket on pedal as far as possible.