

## FORD MOTOR CO. AUTOLAMP

Lincoln Continental  
Continental Mark V

### DESCRIPTION

Autolamp system provides light sensitive automatic on-off control of headlights in conjunction with normal headlight switch operation. A light delay feature is also used to keep headlights on for a preselected time period after ignition is turned off and occupant has left vehicle. Time lapse can be varied up to 4½ minutes before lights turn off automatically. Autolamp system consists of a light sensitive photocell assembly, transistorized amplifier, and time delay control which includes an on-off switch.

### OPERATION

Autolamp wiring parallels the regular light switch wiring, and headlight switch must be turned "OFF", and autolamp control turned "ON" for system to operate automatically. Autolamp control switch is located behind headlight switch knob. In normal operation, system will turn headlights on when natural outside light available to photocell decreases below a predetermined level, such as at sunset. Also, lights will automatically turn off if level of outside light exceeds a predetermined level during daylight hours. System photocell is mounted under a group of perforated holes in upper instrument finish panel on left side. Turning the autolamp control away from "OFF" position will increase lapsed time before headlights turn off after turning ignition switch off. If vehicle is equipped with headlight covers, system will synchronize and control cover opening and closing.

### TESTING

#### SYSTEM OPERATIONAL CHECK

**NOTE** – When a system malfunction is unknown, perform following checkout procedure to isolate problem to a specific condition.

- 1) Check possibility that control unit may be turned "OFF", photocell may be covered or unit is being operated with regular light switch turned "ON".
- 2) Cover photocell and turn ignition "ON". With autolamp control "ON", headlights should come on within 10 seconds. Uncover photocell and lights should turn off.
- 3) Cover photocell and allow time for lights to turn on. Now turn ignition "OFF", lights should remain on for 1½ to 4½ minutes, depending on control setting, and then turn off.

### CIRCUIT TESTS

**Quick Check** – Turn Autolamp control off and headlight switch on. If headlights fail to come on, check headlight circuits. If lights come on, check Autolamp fuse. If fuse is good, check "Sensor Amplifier Adjustment". If fuse and adjustment are good, proceed with tests.

**NOTE** – Refer to illustrations for connector and terminal identification.

**Autolamp (Control Switch) Headlight Circuit Breaker** – Connect test light between ground and terminal 6 or 7. If test light fails, check headlight switch operation. If test light comes on, check continuity of terminal 6 or 7 wire back to headlight switch.

**Taillight Circuit Breaker** – Connect test light between ground and terminal 9. If test light fails, check taillight circuits. If test light comes on, check continuity of terminal 9 wire to headlight switch.

**Autolamp (Control Switch) Ignition Run** – Connect test light between ground and terminal 12. Turn ignition on. If test light fails, check fuse and/or continuity of terminal 12 wire back to fuse panel.

**Headlight Circuit** – Connect test light between ground and terminal 12 or 13. Turn headlights on. If test light fails check continuity of terminal 12 or 13 wire to headlight switch.

**Autolamp (Control Switch) Taillight Circuit** – Connect test light between ground and terminal 4 or 5. Turn headlights to parking or on position. If test light fails, check continuity of terminal 4 or 5 wire to the common connector for taillights.

**Photocell** – Connect ohmmeter between terminals 8 and 11. With photocell in darkness, resistance should not exceed 100K ohms. With light on photocell, resistance should be less than 1K ohms. If test fails, replace photocell and sensor amplifier as a unit.

**Control Switch** – Connect self-powered test light between ground and terminal 3. **CAUTION** – Do not allow test light probe to contact any other terminal. Turn control switch on. If test light fails, perform "Potentiometer Resistance" test. If potentiometer tests good, check continuity of terminal 3 wire to potentiometer connector.

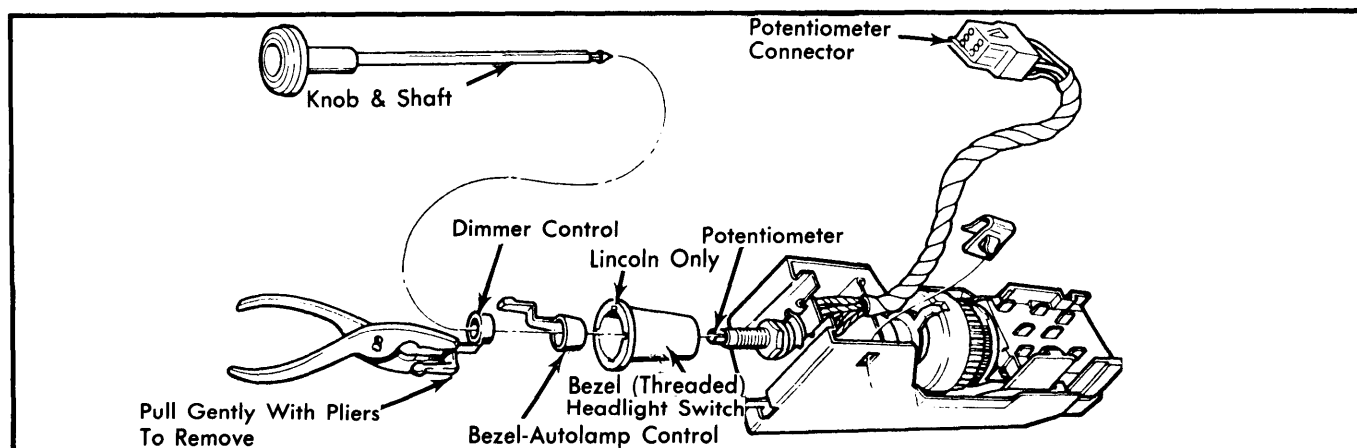

Fig. 1 Ford Motor Co. Autolamp Headlight Switch Assembly

# Headlights – Automatic

## FORD MOTOR CO. AUTOLAMP (Cont.)

**Potentiometer (Off-On)** – Connect ohmmeter between terminals 1 and 2 of amplifier connector. Turn control switch to "MAX" delay. If resistance is not about 200K ohms, perform "Step 2" of "Potentiometer Resistance" test. If potentiometer is good, check continuity of terminal 1 and 2 wires to potentiometer connector. Replace potentiometer if it failed step 2 of resistance test.

**NOTE** – If the preceding tests checked out good and the Autolamp system still has a malfunction, replace sensor amplifier and photocell as an assembly.

**Potentiometer Resistance Test – 1)** Using self-powered test light, check continuity of potentiometer connector terminal 5 to switch bracket. Also check continuity between terminals 5 and 2 while turning control switch from off to on position.

**2)** Using an ohmmeter, check resistance at terminals 1 and 6 while rotating control knob from "OFF" to "MAX" position. Resistance should be 2.5-4.5K ohms at "OFF", up to 140-260K ohms at "MAX".

**3)** If either step 1 or step 2 tests fail, replace potentiometer.

**NOTE** – Terminal 3 and 4 are for the Automatic Headlight Dimmer.

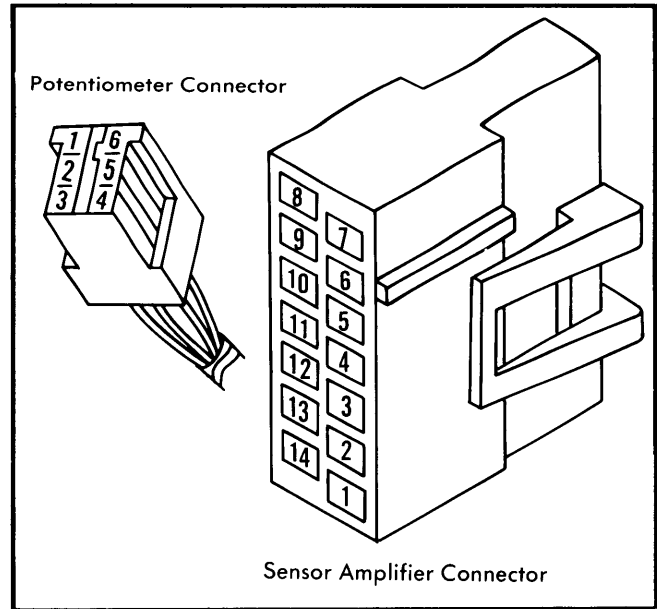

Fig. 2 Autolamp Circuit Connector Terminal Identification

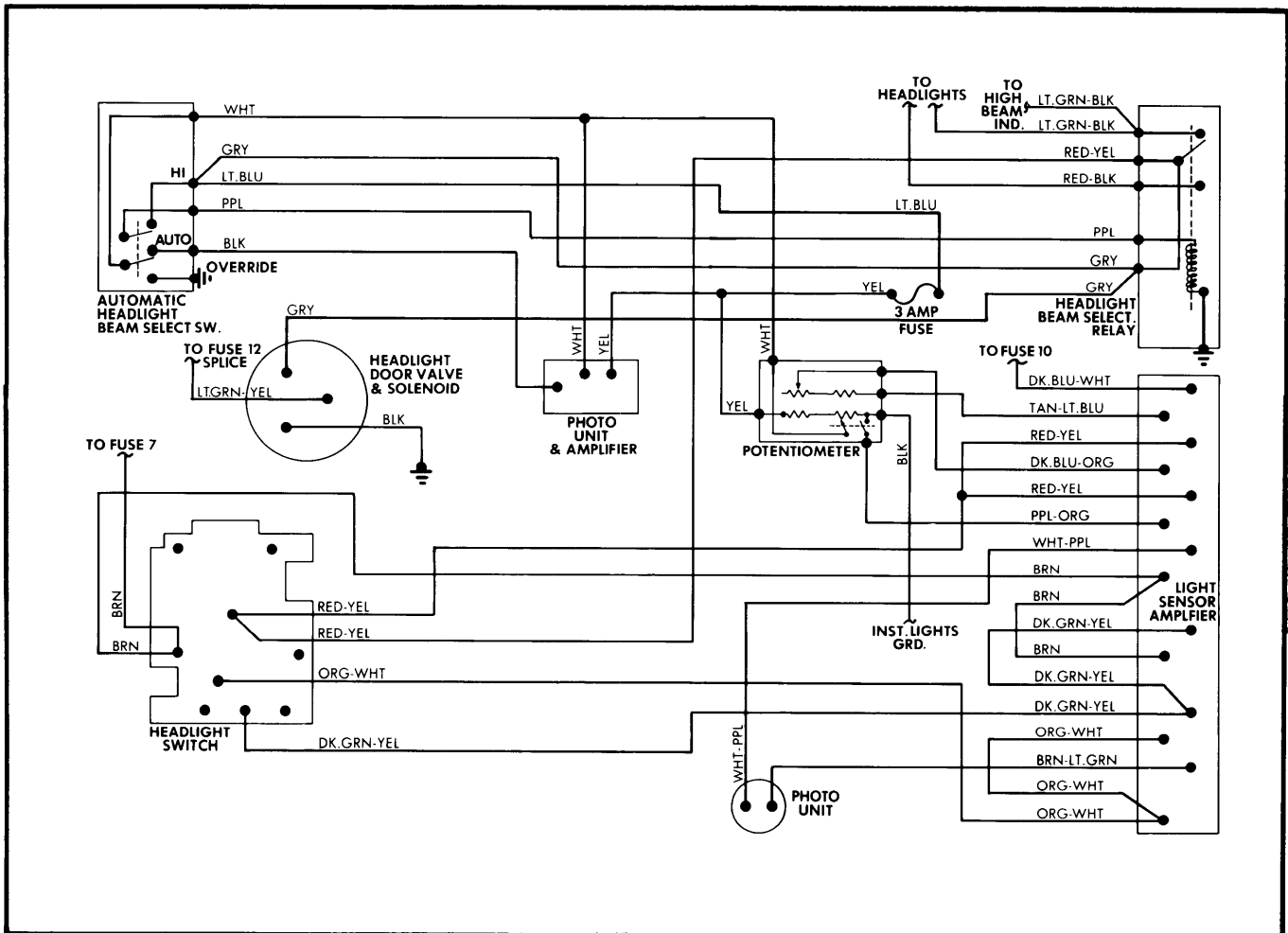

Fig. 3 Continental Mark V Autolamp Wiring Diagram

## FORD MOTOR CO. AUTOLAMP (Cont.)

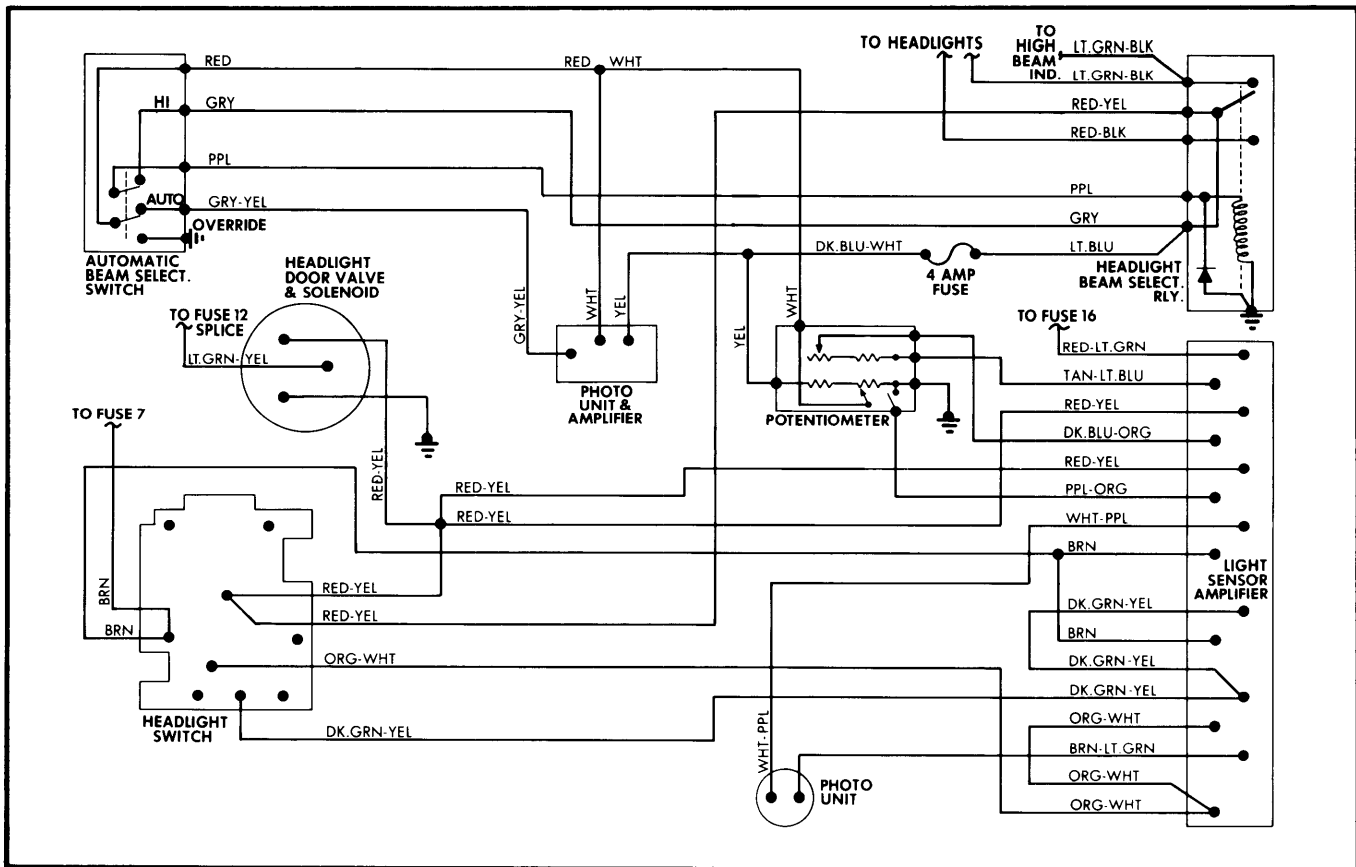

Fig. 4 Lincoln Continental Autolamp Wiring Diagram

### ADJUSTMENT

#### SENSOR AMPLIFIER

There are two different amplifiers utilized. Both amplifiers have a label attached to the case providing adjustment instructions.

### REMOVAL & INSTALLATION

#### SENSOR AMPLIFIER

Remove screws holding sensor amplifier bracket to lower instrument panel support bracket. Remove sensor amplifier wire connector. Remove screws holding bracket to amplifier. To install, reverse removal procedure.

#### HEADLIGHT SWITCH & POTENTIOMETER

**NOTE** – Either headlight switch or potentiometer can be replaced separately. Both units must be removed as an assembly.

1) Disconnect battery ground. Remove headlight switch knob and shaft. Pull both autolamp control bezels off using pliers. Remove threaded headlight switch bezel. On Lincoln, remove single screw in rear corner of bracket. On Mark V, remove cluster opening finish panel. Disconnect all wires and vacuum hoses, then remove switch.

2) Remove bracket from headlight switch (Mark V only). Remove nut and washer from potentiometer. **NOTE** – Before separating potentiometer from bracket, notice how potentiometer is positioned in bracket; reassemble in same position. To install, reverse removal procedure.