

GENERAL MOTORS WINDOW DEFOGGER GRID

DESCRIPTION

The heated rear window system (electric defogger) is an electrically heated grid fused to the inside of the back glass. Window heat is controlled by a switch and relay/timer which will provide heat for approximately 10-15 minutes. System may be turned off at any time by placing the ignition or control switch in "Off" position. **NOTE** – Corvette has "On" and "Off" defogger control switch only, (no relay/timer) and will remain heating until turned off. All systems are designed to operate with engine running and may be re-activated if engine is turned off and re-started.

OPERATION

The heated rear window system is controlled by the ignition switch and a defogger control switch. Both switches must be positioned "ON" to operate system. With switches "ON", current is supplied to the relay/timer and to the rear window.

NOTE – Corvette rear window will heat until ignition or control switch is turned to "OFF" position.

TESTING

SYSTEM TEST

1) Check that all in-line fuses or circuit breakers are operational. Turn ignition and defogger control switch to "On" position. Rear window glass should feel warm to touch after three minutes of operation. If glass does not warm, use a test lamp or ohmmeter and check for 12 volts at feed wire to window grid at rear connector. The location of feed wire connector varies. It will be found either near the left or right upper

corner of glass or in the rear compartment by the rear seat back, and will be either a Purple or Black wire depending on model. If voltage is correct, and window is not warm, check rear window grid wires as described in this story. If voltage is not correct, check wiring harness, control switch or timer/relay.

2) Test defogger control switch for shorts and replace switch if it is shorted. Some switches must be removed from panel to perform check. Check system for correct operation. If system is inoperative install a new relay/timer (locations vary) and check operation of system. If system does not operate, locate and repair short in the wiring circuit.

WINDOW GRID WIRES

1) Shine a strong light through grid from inside vehicle. Check for broken grids which will appear as brown spots.

2) Run engine at idle, turn control switch to "On", the indicator light should come on.

3) Using a 12 volt DC voltmeter, contact wide silver strips on back window. Reading should be 10-13 volts. If voltage is lower, window grid ground connection (pigtail on passengers side) is loose.

4) Contact a known good ground with meter negative lead. Reading should not change.

5) With negative lead connected to ground, touch each grid line at its midpoint with meter positive lead. A reading of about 6 volts indicates grid line is good. A zero volts reading indicates the grid is broken between the mid-point and the hot side. A 12 volts reading indicates the grid is broken between the mid-point and ground, or that ground connection is loose.

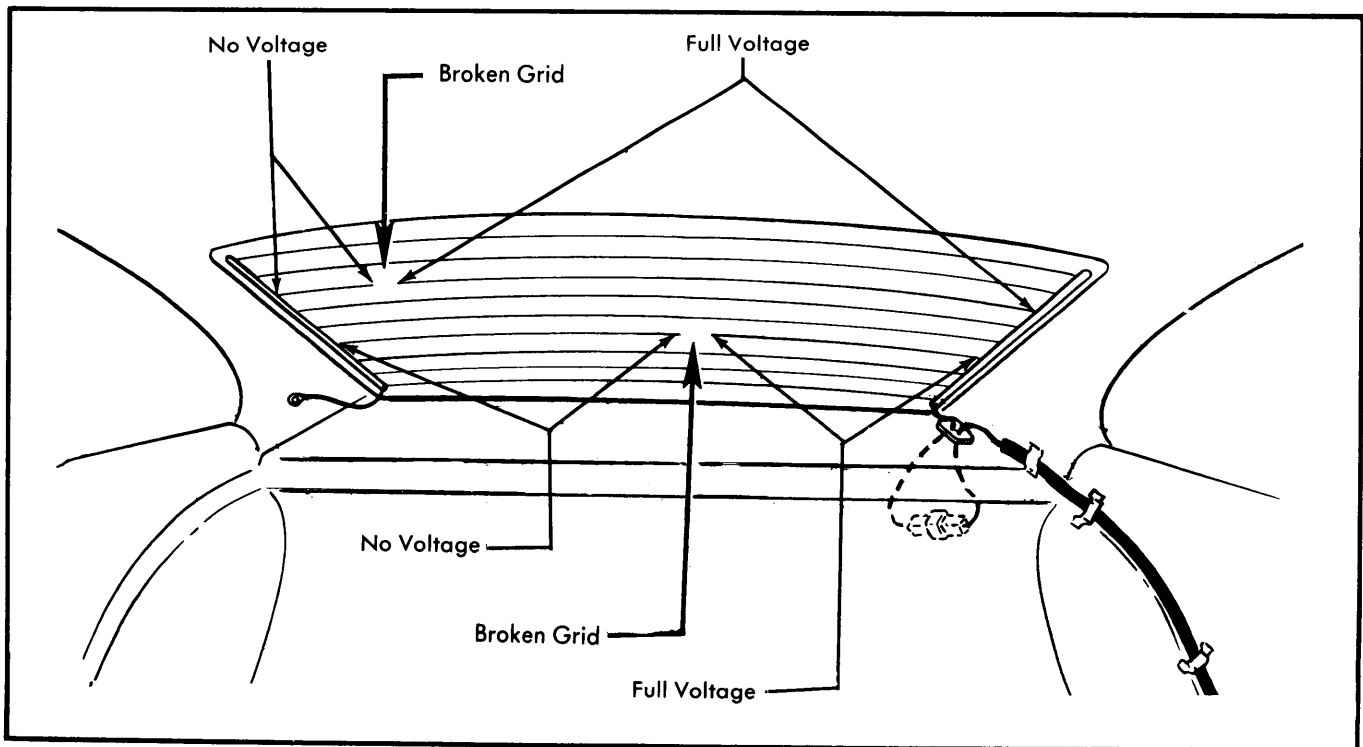

Fig. 1 Voltage Test with Broken Grid Wires

Defoggers — Rear Window

GENERAL MOTORS WINDOW DEFOGGER GRID (Cont.)

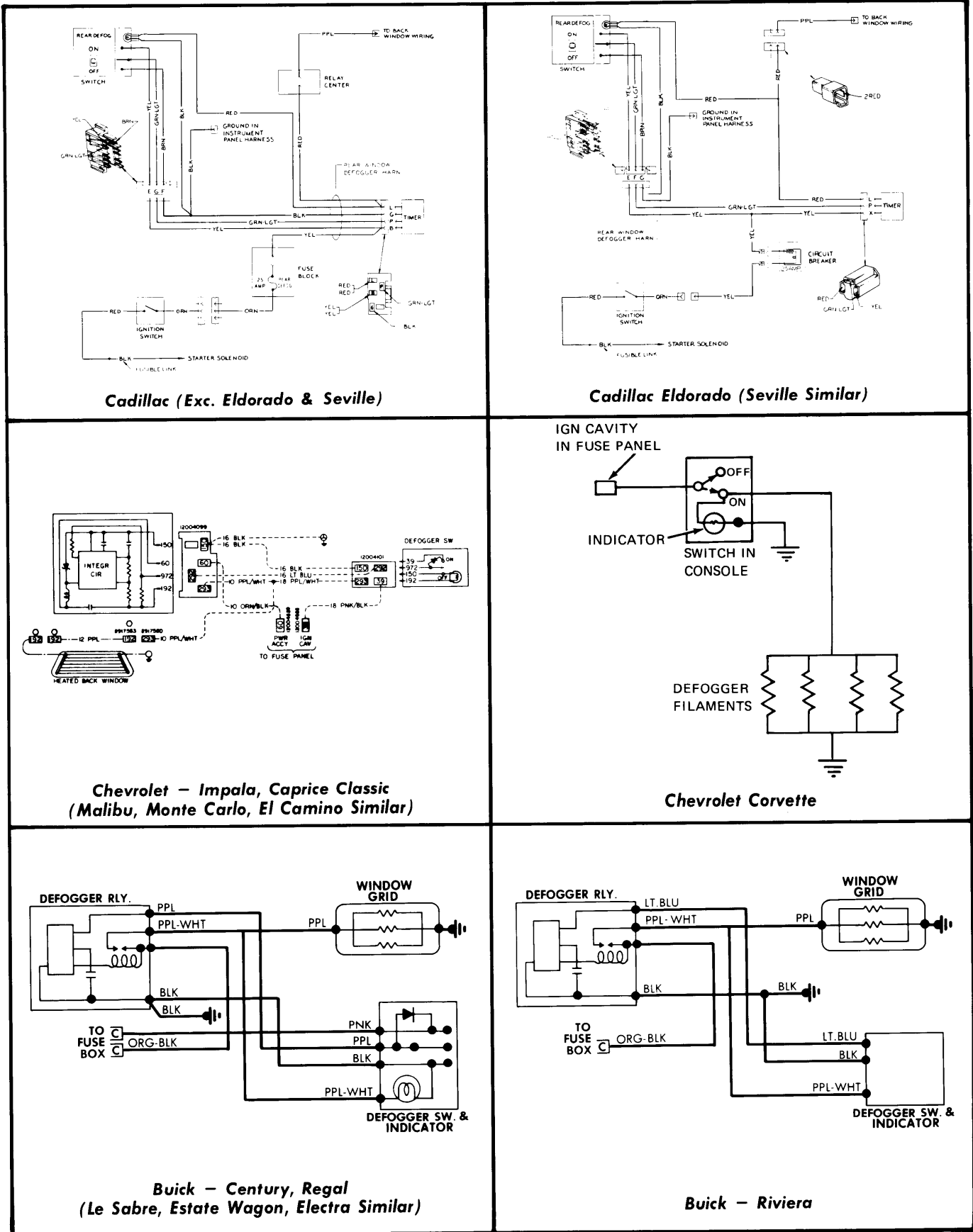

Fig. 2 General Motors Electric Window Defogger Wiring Diagrams

GENERAL MOTORS WINDOW DEFOGGER GRID (Cont.)

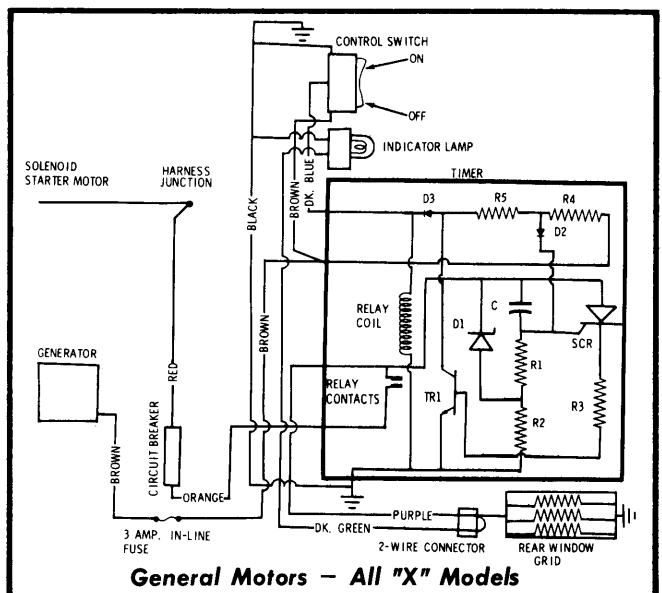
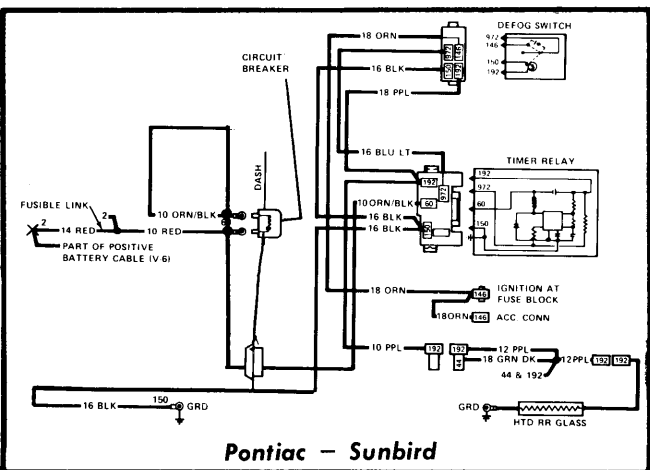
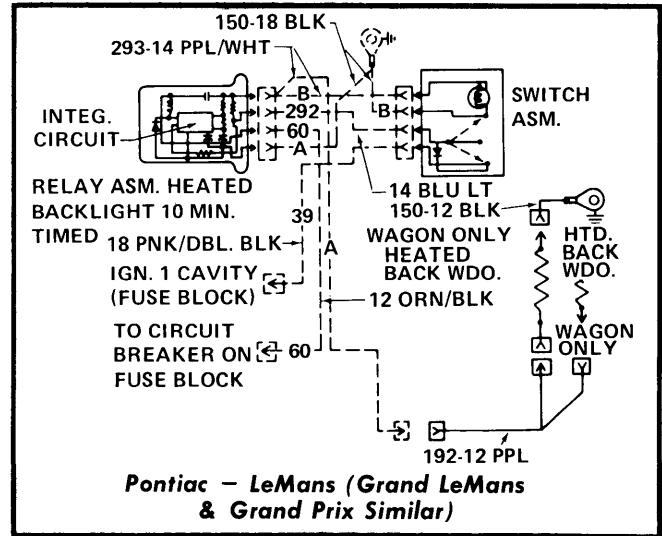
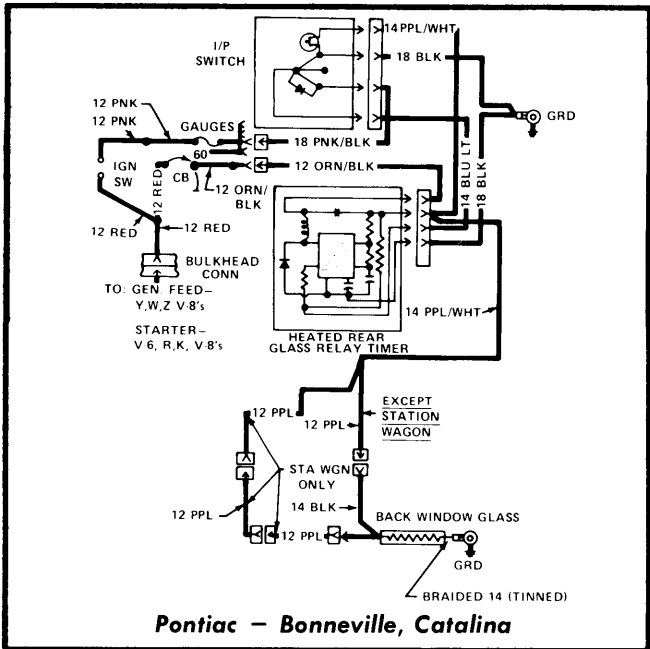
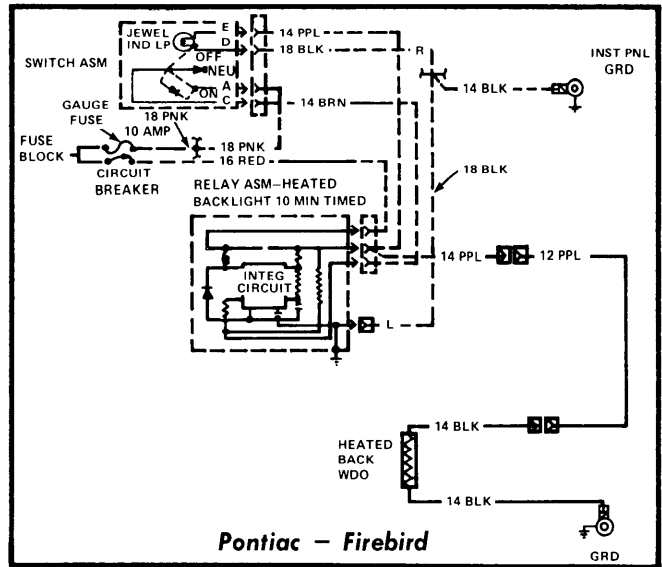
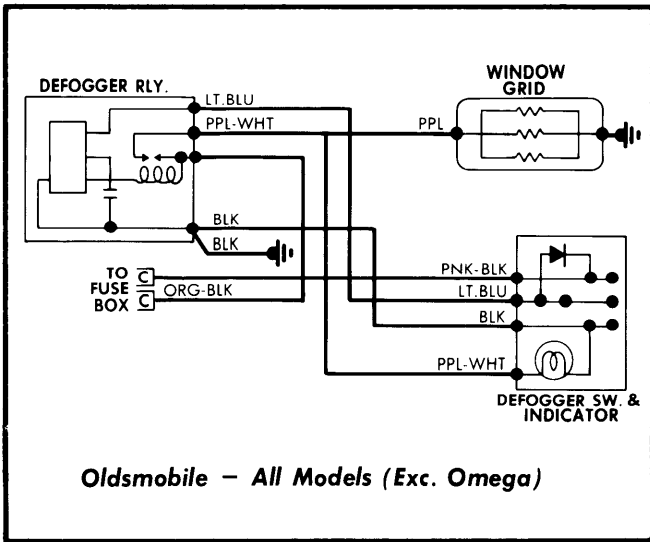

Fig. 3 General Motors Electric Window Defogger Wiring Diagrams