

MOTORCRAFT WITH SEPARATE REGULATOR

Ford Motor Co.

TESTING

DESCRIPTION

Alternator is belt driven from engine. Current is supplied from Alternator-Regulator system, to rotating field of alternator through two brushes to two slip rings. Power is produced in form of alternating current which is rectified to direct current by six diodes. Alternator regulator automatically adjusts alternator field current to maintain alternator output voltage within prescribed limits to correctly charge battery. Regulator is electronic all solid state and consists of transistors, diodes and resistors. The electronic regulator is used on all charging systems.

IDENTIFICATION & SPECIFICATIONS

Alternator is color-ink stamped with "Motorcraft" trademark. Color stamp is code for rated amperage output. Rated amperage is also stamped on end frame (40A, 60A, etc.). Color code is as follows.

Application	Amperage @ 15V.	Rated Output Speed (Engine RPM)
-------------	-----------------	---------------------------------

Orange	40	2900
Green	60	2900
Black	70	① 1640
Red	100	② 2900

① — Rated cold output.

Specifications

Alternator	Specification
Field Current at 12 volts (All)	4.0 Amps.
Slip-Rings (All)	
Minimum Diameter	1.22"
Maximum Runout0005"
Brush Length Wear Limit (All)	5/16"
Pulley Nut Torque (All)	60-100 ft. lbs.

SERVICE

CAUTION — When testing or servicing alternator or regulator, take following precautions to avoid damage to components:

Battery — Do not reverse battery connections. Negative terminal must be connected to ground. When charging battery, cables must be disconnected from battery before connecting charger. Do not use charger as a booster for starting engine. If booster battery is used to start engine, negative cable of booster must be connected to negative cable of vehicle battery.

Alternator — Do not ground field circuit between alternator and regulator, or operate alternator on an open circuit with field winding energized. Do not ground output terminal or attempt to polarize alternator as polarization is not required.

Regulator — Turn ignition switch off when working on regulator. Use care to prevent a short circuit between regulator relay and regulator base while working on components.

VOLTMETER TEST PROCEDURES

NOTE — When performing charging system test with a voltmeter, turn off all lights and electrical components. Be sure battery specific gravity is at least 1.200.

1) Connect negative lead of voltmeter to negative battery post and positive lead to positive battery post. Record battery voltage.

2) Attach suitable tachometer and start engine. Operate at 1500 RPM with no electrical load, voltmeter reading should increase 1-2 volts above battery voltage. Reading should be taken when voltmeter needle stops moving.

3) With engine operating, turn on heater or A/C blower motor to "high" position and turn on headlights to high beam. Increase RPM to 2000, voltmeter should indicate a minimum of .5 volt increase over battery voltage. If system conforms to these readings, operation is normal.

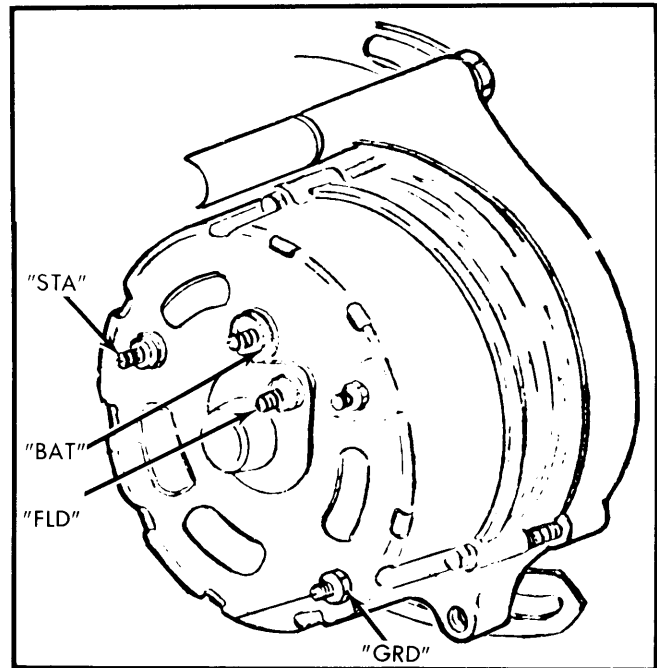

Fig. 1 View Showing Terminal Location for Rear Terminal Type Alternators

TEST RESULTS

1) If voltmeter reading indicates over-voltage (more than two volts above battery voltage), shut off engine and check ground connections between regulator and alternator and/or regulator and engine. Clean and tighten connections, then repeat tests.

2) If over-voltage condition still exists, disconnect regulator wiring plug and repeat test. If condition is corrected, replace regulator and repeat test.

MOTORCRAFT WITH SEPARATE REGULATOR (Cont.)

3) If over voltage still exists with regulator disconnected, a short is indicated in wiring harness between alternator and regulator. Repair short circuit, then replace voltage regulator and repeat tests with regulator plug connected.

4) If voltmeter reading does not increase at least one volt, check for presence of battery voltage at alternator "BAT" terminal, and at regulator plug "A" terminal. If no voltage is present, an open wire is indicated. Repair wire and repeat tests.

FIELD CIRCUIT & ALTERNATOR TESTS

1) Voltmeter does not indicate more than $\frac{1}{2}$ volt above base voltage. Disconnect wiring plug from regulator and connect an ohmmeter from "F" terminal to ground. Ohmmeter should indicate more than 3 ohms. If less, repair grounded field circuit and repeat tests.

2) Field circuit should be checked with regulator wiring plug disconnected and suitable ohmmeter connected from "F" terminal of regulator wiring plug to battery ground. Ohmmeter should indicate between 4 and 250 ohms.

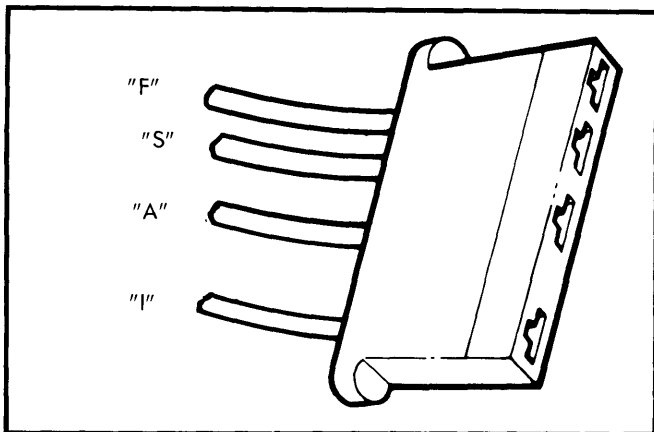

Fig. 2 Regulator Plug Wire Connections

3) If field circuit is satisfactory, disconnect regulator wiring plug at regulator and connect jumper wire between "A" and "F" terminals on regulator wiring plug. Repeat voltmeter test procedures. If problem of under-voltage still exists, remove jumper wire at regulator plug and leave plug disconnected from regulator, connect jumper wire to "FLD" and "BAT" terminals on alternator. Repeat voltmeter test procedures. If results are now satisfactory, repair wiring harness from alternator to regulator. If voltmeter tests still indicate under-voltage, repair or replace alternator.

REGULATOR CIRCUIT TESTS

"S" Circuit With Ammeter — Connect positive voltmeter lead to regulator wiring plug "S" terminal position. Turn ignition "ON", but do not start engine. Voltmeter should indicate battery voltage. If there is no voltage, the "S" wire lead from ignition switch is open. Repair and retest system.

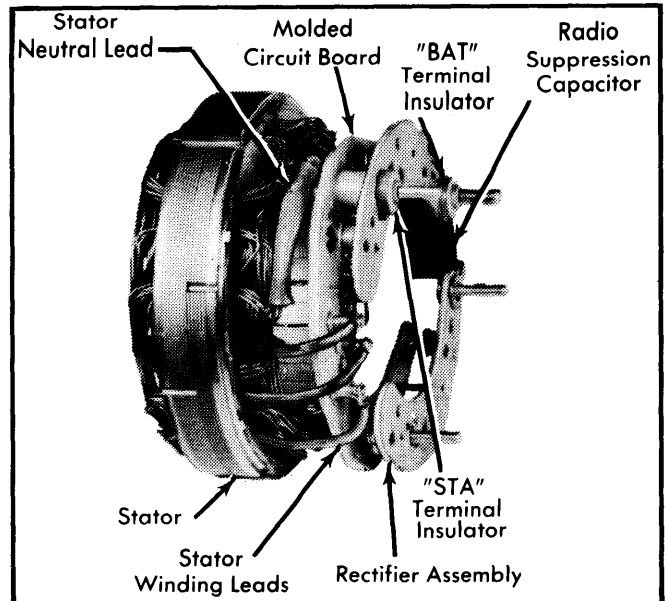

Fig. 3 View Showing Stator Components and Lead Connections

"S" & "I" Circuit With Indicator Light — Disconnect regulator wiring plug and install a jumper wire between "A" and "F" terminals. With engine idling, connect positive lead of voltmeter to "S", and then "I" terminals of regulator wiring plug. Voltage of "S" circuit should be about $\frac{1}{2}$ of "I" circuit. If no voltage is present, repair alternator or wiring circuit at fault. If circuit tests are satisfactory, install a new regulator.

DIODE TEST (ON VEHICLE)

Disconnect electric choke (if equipped) and voltage regulator plug. Connect jumper wire between "A" and "F" terminals of voltage regulator wiring plug. Connect voltmeter to battery posts, start and run engine at idle speed, then record voltmeter reading. Move positive voltmeter lead to "S" terminal of alternator and note voltmeter reading. If meter reads $\frac{1}{2}$ of battery voltage, diodes are in working order. If meter reads approximately 1.5 volts, alternator has shorted negative diode or grounded stator winding. If meter reads approximately 1.5 volts less than battery voltage, alternator has shorted positive diode. If meter reads approximately 1.0-1.5 volts less than $\frac{1}{2}$ of battery voltage, alternator has an open positive diode. If meter reads about 1.0-1.5 volts more than $\frac{1}{2}$ battery voltage, alternator has an open negative diode. Reconnect electric choke (if equipped) back into circuit after test is completed.

BENCH TESTS

Rectifier Shorted Or Grounded and Stator Grounded Test

— 1) Use a calibrated ohmmeter and set knob at 10. Connect one ohmmeter probe to alternator "BAT" terminal and other probe to "STA" terminal (rear blade terminal), then reverse terminal probes and repeat test.

2) Reading of 60 ohms or less in both directions indicates bad negative diode, grounded positive diode, or grounded "BAT" terminal.

MOTORCRAFT WITH SEPARATE REGULATOR (Cont.)

3) Perform same test using "STA" or "GND" terminals of alternator. Readings in both directions indicate either bad negative diode, grounded stator winding, grounded stator terminal, grounded positive diode plate, or grounded "BAT" terminal. Infinite reading (no needle movement) in all four probe positions in the preceding tests indicates an open "STA" terminal lead connection inside alternator.

Field Open or Short Circuit Test — Set ohmmeter knob at 1 and calibrate meter as directed by manufacturer. Contact alternator "FLD" terminal with one probe and "GRD" terminal with other probe, then spin alternator pulley. Ohmmeter should read between 2.4 and 250 ohms, and should fluctuate while pulley is spinning. Infinite reading (no needle movement) indicates open brush lead, worn or stuck brushes, or bad rotor assembly. Meter reading of less than 2.4 ohms indicates grounded brush assembly, grounded field terminal, or bad rotor.

Diode Test — Remove rectifier assembly from alternator. Set meter knob at 10 and calibrate instrument. To test one set of diodes, contact one probe to terminal bolt and contact each of three stator lead terminals with other probe. Reverse probes and repeat test. All diodes should show readings of about 60 ohms in one direction, and infinite readings with probes reversed. Repeat test for other set of diodes, moving first probe to other terminal screw. If meter readings are not as specified, replace rectifier assembly.

Stator Coil Open Or Grounded Test — Following tests are to determine if stator coil is operating properly. Disassemble stator from alternator. Set ohmmeter knob at 1000. Contact meter probe to one stator lead and other probe to stator laminated core. Meter should show infinite. If meter needle moves, stator winding is shorted to core and must be replaced. Repeat test for each one of stator leads.

Rotor Open or Short Circuit Test — Disassemble front housing and rotor from rear housing. Set ohmmeter knob at 1 and calibrate meter. Contact each probe to a rotor slip ring. Meter should read 2.4-4.9 ohms. Higher reading indicates damaged slip ring solder connection, or broken wire. Lower reading indicates shorted wire or slip ring. Replace rotor if damaged. Contact one meter probe to slip ring and other probe to rotor shaft. Meter reading should be infinite (no needle deflection), reading other than infinite indicates rotor is shorted to shaft. If shorted replace rotor.

NOTE — Slip ring terminals or solder touching rotor shaft will cause shorted condition.

ADJUSTMENTS

ALTERNATOR REGULATORS

Electronic Type — Electronic regulator is used on all charging systems and is factory calibrated and cannot be adjusted.

OVERHAUL

DISASSEMBLY

Rear Terminal — 1) Mark both housings and stator with scribe for reassembly. Remove through bolts. Separate front housing and rotor from stator and rear housing. Remove all nuts and insulators from rear housing and remove rear housing from stator.

2) Remove brush holder mounting screws, holder, brushes, springs, insulator, and terminal. If replacement is necessary, press bearing from rear housing, supporting housing on inner boss. If rectifier assembly is being replaced, unsolder stator leads from rectifier terminals and separate stator from rectifier assembly. **NOTE** — Use suitable 100 watt soldering iron.

3) Original Production alternators will have one of two types of rectifier assembly circuit boards; one has circuit board spaced away from diode plates with diodes exposed, the other is a single circuit board with built in diodes. If alternator rectifier has exposed diode board, remove screws from rectifier by rotating bolt heads $\frac{1}{4}$ turn clockwise to unlock, and then remove screws. Push stator terminal straight out, on a rectifier with diodes built into circuit board. Avoid turning screw while removing to make certain straight knurl will engage insulators when installing. Do not remove the grounded screw.

4) Remove drive pulley nut using suitable tool, then pull lock washer, pulley, fan, fan spacer, rotor and rotor stop from rotor shaft. Remove screws holding front end bearing retainer and remove retainer. If bearing has lost lubricant or is damaged, support housing close to bearing boss and press out old bearing.

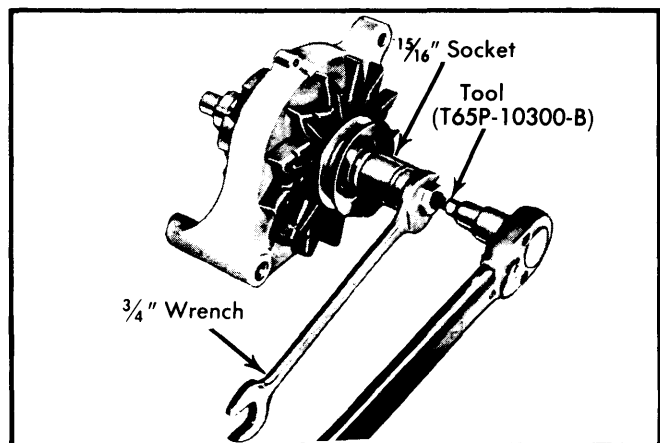

Fig. 4 View Showing Proper Tools for Removing Pulley

REASSEMBLY

1) Rotor, stator, and bearings must not be cleaned with solvent. Wipe these parts off with suitable clean cloth. Press front bearing in front housing bearing boss, putting pressure on bearing outer race only. Install bearing retainer. If stop-ring on rotor drive shaft is damaged, install new stop-ring. Push new ring on shaft and into groove. **NOTE** — Do not open ring with snap ring pliers as permanent damage will result.

MOTORCRAFT WITH SEPARATE REGULATOR (Cont.)

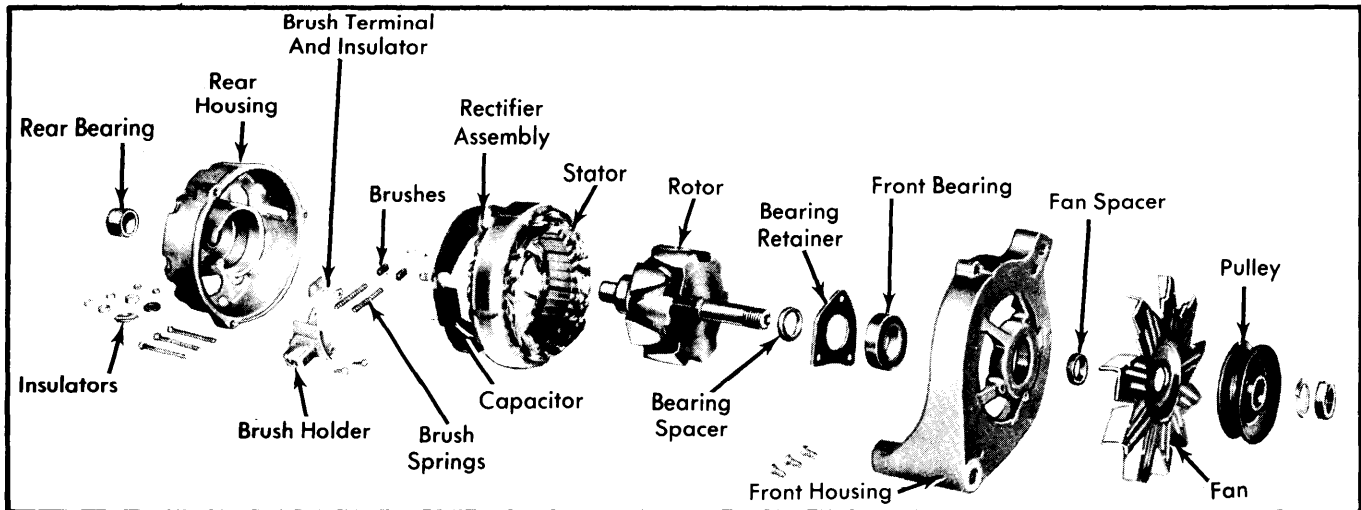

Fig. 5 Exploded View of Rear Terminal Alternator

2) Position rotor stop on drive shaft with recessed side against stop-ring. Position front housing, fan spacer, fan, pulley, and lock washer on drive shaft and install retaining nut. Tighten retaining nut using suitable tool.

3) If rear housing bearing was removed, support housing on inner boss and press in new bearing flush with outer end surface. Place brush springs, brushes, brush terminal, and terminal insulator in brush holder and hold brushes in position by inserting small piece of stiff wire in brush holder. Position brush holder assembly in rear housing and install mounting screws. Position brush leads in holder.

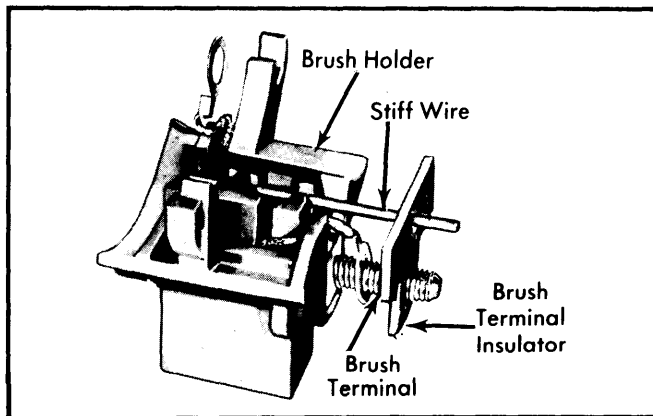

Fig. 6 Brush Holder Assembly with Wire for Retaining Brushes in Place Inserted Through Holes

4) Wrap three stator winding leads around rectifier terminals and solder using suitable 100 watt soldering iron and rosin-core solder. Position stator neutral lead eyelet on stator terminal screw and install screw in rectifier assembly.

5) For rectifier with diodes exposed, insert special screws through wire lug, dished washers, and circuit board. Turn screw ¼ turn counterclockwise to lock. For single circuit boards with built-in diodes, insert screws straight through wire lug, insulating washer and rectifier, into insulator.

Flat insulating washers are to be used between stator terminal and board when single circuit board is used.

NOTE — Dished washers are to be used only on circuit board with exposed diodes. If dished washers are used on single circuit board, short circuit will occur.

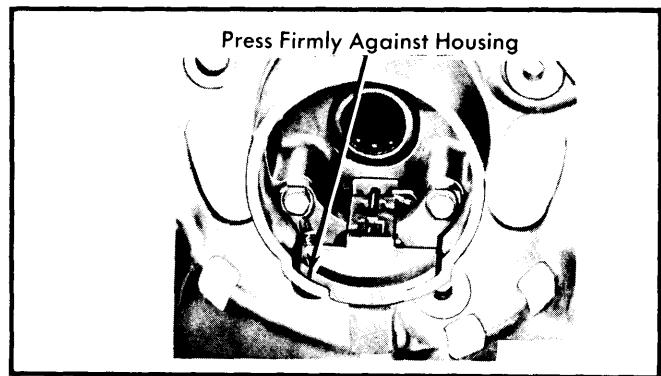

Fig. 7 View Showing Proper Positioning of Brush Leads

6) Position capacitor on rectifier terminals. On circuit board with exposed diodes, install "STA" and "BAT" terminal insulators. On single circuit board, position square stator terminal insulator in rectifier assembly. Position "BAT" terminal insulator on "BAT" terminal. Position stator and rectifier assembly in rear housing. Make certain all terminal insulators are seated properly in appropriate recesses. Position "STA" (black), "BAT" (red), and "FLD" (orange) insulators on terminal bolts and install retaining nuts.

7) Wipe rear end bearing of rotor shaft with clean, lint free cloth. Position rear housing and stator assembly over rotor and align scribe marks made during initial disassembly. Seat machined portion of stator core into step in both end housings. Install housing through bolts. Remove brush retracting wire, and put small amount of water-proof cement over hole to seal from moisture.

MOTORCRAFT WITH SEPARATE REGULATOR (Cont.)

DISASSEMBLY

Side Terminal — 1) Remove brush holder and cover assembly from rear end housing. Mark both end housings and stator with scribe for reassembly. Remove housing through bolts and separate front housing and rotor from stator and rear housing.

2) Remove drive pulley nut, lock washer, flat washer, pulley, fan, fan spacer and rotor from front housing. Remove screws holding front bearing retainer and remove retainer. If bearing is damaged or has lost lubricant, support housing close to bearing boss and press out bearing from housing.

3) Remove all nut and washer assemblies and insulators from rear housing, remove rear housing from stator and rectifier assembly. If replacement is necessary, press bearing from rear housing, supporting housing on housing inner boss. Unsolder stator leads from rectifier assembly and separate stator from assembly. **NOTE** — Use suitable 200 watt soldering iron.

REASSEMBLY

1) If front bearing is being replaced, press new bearing into bearing boss putting pressure on outer race only. Install bearing retainer and tighten retainer screws until tips of retainer touch housing. Position rectifier assembly to stator, wrap stator leads around rectifier terminals and solder connections using 200-watt soldering iron and rosin core solder.

2) If rear housing bearing was removed, press in new bearing from inside of housing until bearing is flush with outer end surface. Put pressure on bearing outer race only. Install "BAT"- "GRD" insulator. Position stator and rectifier assembly in rear end housing. Install "STA" (purple) and "BAT" (red) terminal insulators on terminal bolts and install nut and washer

assemblies. **NOTE** — Make certain that shoulders of all insulators, both inside and outside of housing, are seated properly before tightening nuts.

3) Position front housing over rotor and install fan spacer, fan, pulley, flat washer and lock washer, and nut on rotor shaft. Wipe rear end bearing surface of rotor shaft with clean cloth. Position rotor with front housing into stator and rear housing assembly, and align scribe marks made during disassembly. Seat machined portion of stator core into step in both housings and install through bolts.

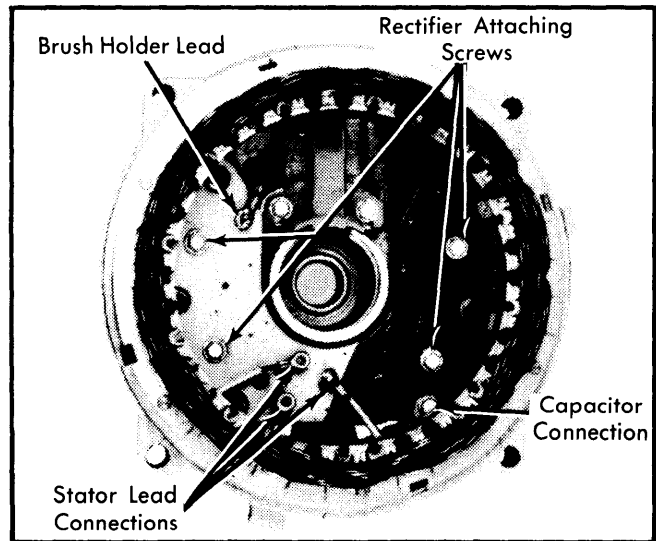

Fig. 8 Side Terminal Alternator Lead Connections

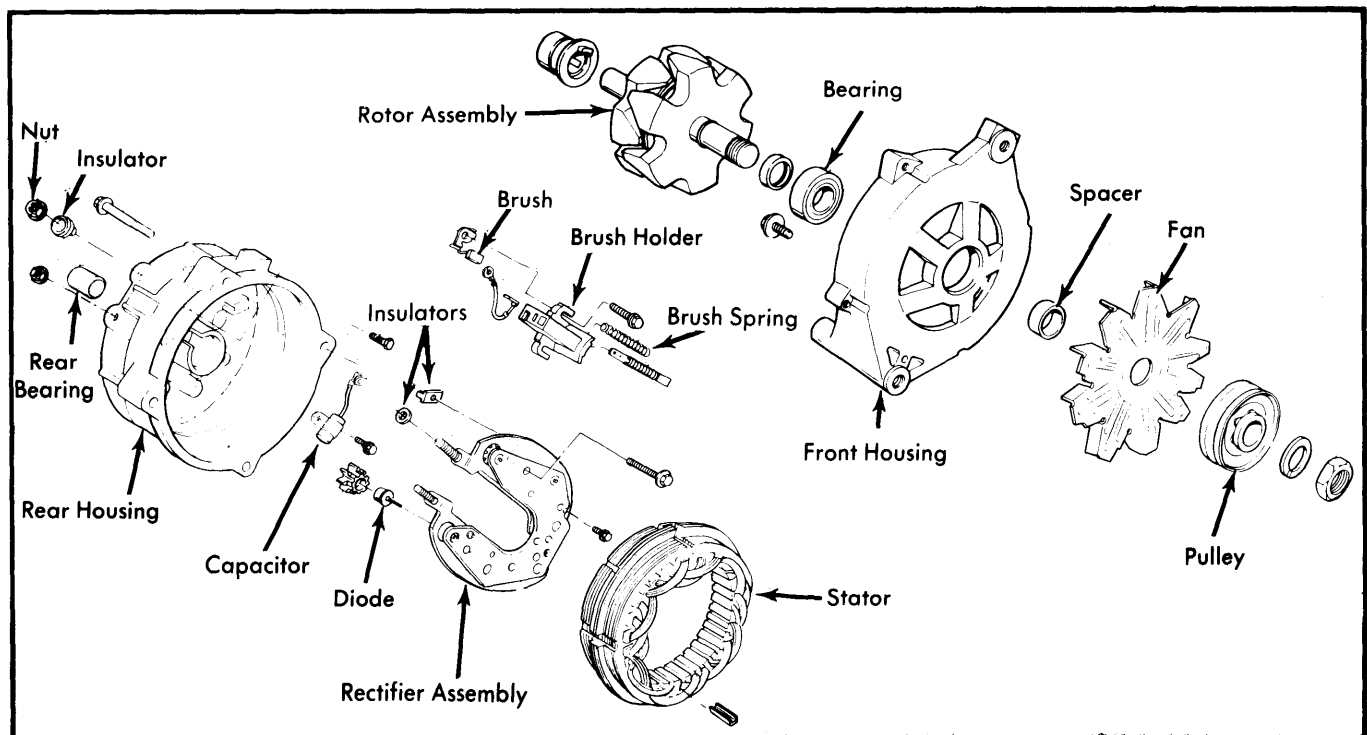

Fig. 9 Exploded View of Side Terminal Alternator

MOTORCRAFT WITH SEPARATE REGULATOR (Cont.)

4) Hold brushes in position by inserting stiff wire into brush holder. Position brush holder and cover assembly to rear housing and install mounting screws. Remove brush retracting wire and seal hole with small amount of water-proof cement.

BRUSH REPLACEMENT

Brush Replacement – 1) Remove brush holder and cover assembly from rear housing. Remove terminal bolts from brush holder and cover assembly and remove brush assemblies. Position new brush terminals on terminal bolts and assemble ter-

minals, bolts, and brush holder washers, and nuts. Insulating washer mounts under "FLD" terminal nut. Entire brush and cover assembly is also available from service.

2) Depress brush springs in brush holder cavities and insert brushes on top of springs. Hold brushes in position by inserting a stiff wire in brush holder. Position brush leads as required. Install brush holder and cover assembly to rear housing. Remove brush retracting wire and seal with small amount of water-proof cement.

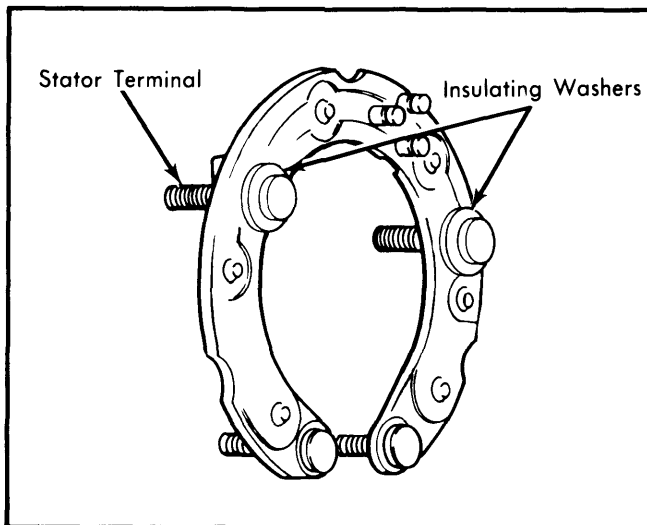

Fig. 10 Rectifier Assembly with Built-in Diodes

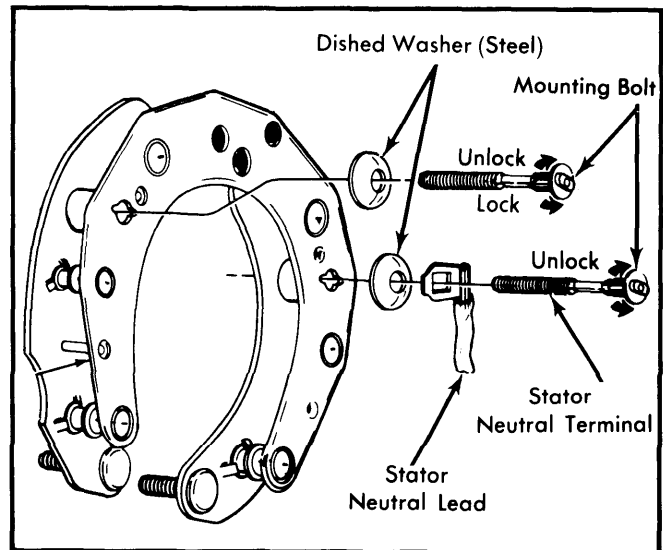

Fig. 11 Rectifier Assembly with Exposed Diodes