

DELCO-REMY WITH INTEGRAL REGULATOR

American Motors
4 & 6 Cylinder Models
General Motors
All Models

DESCRIPTION

The Delcotron 10 SI, 15 SI and 27 SI alternators with integral regulators feature a solid state regulator mounted inside the alternator. The 10 SI model is available with different outputs at idle and different maximum outputs. The 15 SI and 27 SI models put out 50 amps at idle with an 80 amp continuous output. The construction and operation of all models is basically the same. Delcotrons consist primarily of two end assemblies, rotor, stator, brushes, slip rings and diodes. Rotor is supported in drive end frame by ball bearings and in slip ring end frame by roller bearings. Bearings contain enough lubricant to eliminate the need for periodic lubrication.

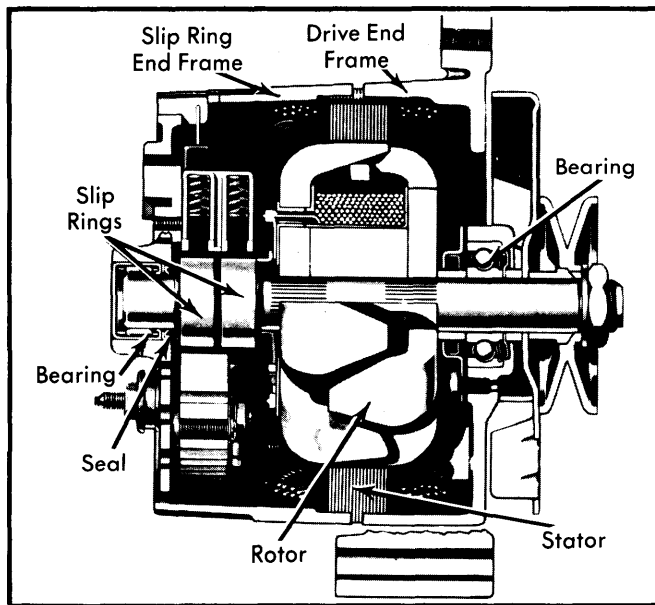

Fig. 1 Cross-sectional View Showing Internal Components of Delcotron Integral Alternator Regulator

OPERATION

Two brushes carry current through the slip rings to the field coil mounted on the rotor. The stator windings are assembled on the inside of a laminated core that forms part of the alternator frame. A rectifier bridge connected to the stator windings contains 6 diodes (three positive and three negative) molded into an assembly. This rectifier bridge changes stator a.c. voltage into d.c. voltage which appears at output terminal. The blocking action of the diodes prevents battery discharge back through the alternator. Because of this blocking action the need for a cutout relay is eliminated. Generator field current is supplied through a diode trio which is also connected to the stator windings. A capacitor is mounted in the end frame and protects rectifier bridge and diodes from high voltages.

ADJUSTMENTS

No periodic adjustments or maintenance of any kind is required on entire generator assembly. Regulator voltage is preset and no adjustment facility is provided.

CAUTION — Do not attempt to polarize alternator. Do not short or ground any terminals except as instructed. Never operate alternator with battery out of circuit or output terminal open. Alternator and battery must share same ground polarity.

TESTING

NOTE — Before making electrical checks, visually inspect all terminals for clean and tight connections. Check alternator mounting bolts and drive belt tension. Do not ground No. 2 lead wire. Battery must be in good condition to test charging system.

UNDERCHARGED BATTERY

1) With ignition switch at "ON" position, connect a voltmeter from, alternator "BAT" terminal to ground, then from No. 1 terminal to ground, (see illustration) and No. 2 terminal to ground. A zero reading indicates an open between connection and battery. An open No. 2 lead will cause uncontrolled voltage. This may cause overcharge and possible damage to accessories. Opens in this circuit may be between terminals at the crimp between harness wire and terminal, or in wire.

NOTE — If preceding test is satisfactory, continue to next step.

2) Disconnect battery ground cable. Connect an ammeter in the circuit at the "BAT" terminal of alternator. Reconnect battery ground cable. Turn on all available accessories. Connect a carbon pile across battery. Operate engine at moderate speed and adjust carbon pile as required to obtain maximum current output. If ampere output is within 10 amps of rated output as stamped on alternator case, alternator is good. If output is not within 10 amps of rated output, ground the field winding by inserting a screwdriver into test hole. See Fig. 3. **CAUTION** — Tab is within $\frac{3}{4}$ " of casting surface, do not force screwdriver deeper than one inch into end frame.

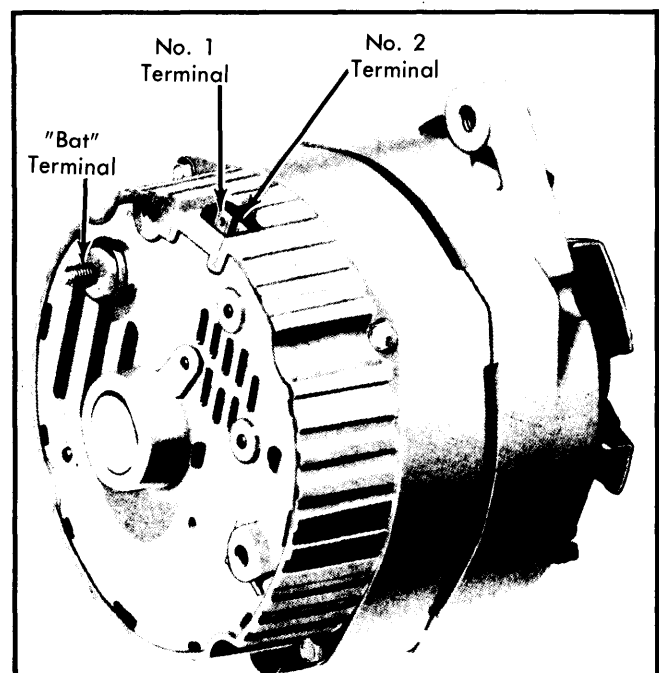

Fig. 2 Identification of Delcotron Terminal Locations

DELCO-REMY WITH INTEGRAL REGULATOR (Cont.)

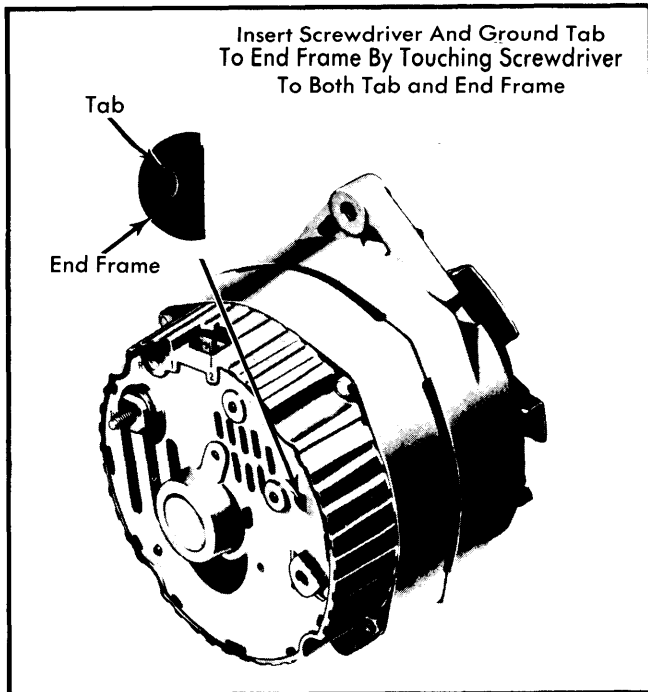

Fig. 3 View Showing Field Ground Tab Accessible through Hole in End Frame

GENERATOR OUTPUT TEST

1) To bench check alternator proceed as follows: Make connections as shown in illustration, except leave carbon pile disconnected. Use a fully charged battery, and a 10 Ohm resistor rated at 6 watts or more between alternator No. 1 terminal and battery. Slowly increase alternator speed and observe voltage. If voltage is uncontrolled with speed and increases above 16 volts, check for a grounded brush lead clip. If brush lead clip is OK replace regulator.

2) Connect carbon pile. Operate alternator at moderate speed and adjust carbon pile to obtain maximum output. If output is within 10% of rated output as stamped on alternator frame, alternator is good. If not, ground generator field with a screwdriver. If output is now within 10% of rated output, regulator is defective.

OVERCHARGED BATTERY

Connect a voltmeter from alternator No. 2 terminal to ground. If reading is zero, No. 2 lead circuit is open. If No. 2 lead circuit checks out good, alternator will have to be disassembled for further checks (see OVERHAUL).

OVERHAUL

DISASSEMBLY

1) Hold alternator in a vise, clamping mounting flange lengthwise. Remove thru bolts and separate slip ring end frame and stator assembly from drive end and rotor assembly by prying apart with a screwdriver at stator slots.

2) Place a piece of tape over slip ring end frame bearing to prevent entry of dirt. At this point brushes may drop onto rotor shaft and become contaminated with bearing lubricant, clean brushes as soon as possible with a suitable cleaner (acetone) to keep them from becoming grease soaked.

3) Remove stator lead attaching nuts and separate stator from end frame. Remove screw attaching diode trio to brush holder and remove diode trio from end frame. Remove rectifier bridge attaching screw and "BAT" terminal screw, and disconnect capacitor lead. Remove rectifier bridge from end frame. Remove brush holder and regulator. Note that two insulators are assembled over top of brush retaining clips, and that the two screws have special insulating sleeves.

4) Remove capacitor from end frame. Remove slip ring end frame bearing if necessary. Remove pulley nut by holding shaft with an Allen wrench. Remove pulley. Remove rotor and spacers from drive end frame assembly. If necessary remove drive end frame bearing retainer plate, then gasket and bearing.

INSPECTION

Wash all metal parts except bearings and stator, and rotor. Inspect rotor slip rings, they may be cleaned with 400 grain polishing cloth. Slip rings may be lathe turned to a .002" indicator reading. Slip rings are not replaceable, excessive damage will require rotor replacement. Inspect brushes for wear, if they are worn halfway, replace them.

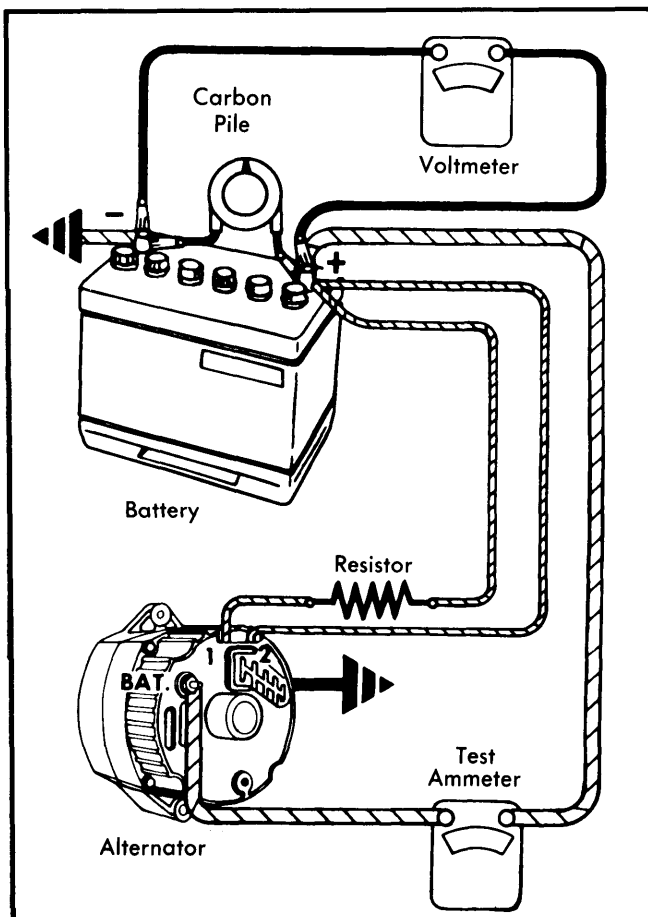

Fig. 4 Alternator Bench Test Connections

DELCO-REMY WITH INTEGRAL REGULATOR (Cont.)

TESTING (ON BENCH)

Rotor Field Winding — Check rotor for grounds or an open circuit with a 110 volt test lamp or ohmmeter (see illustration). Test for grounds between slip ring and rotor shaft; no continuity should exist. Test for an open field by connecting test leads across slip rings, continuity should be obtained. Test for shorts by connecting a 12 volt battery and ammeter in series with both slip rings, or an ohmmeter may be used. Current draw should be 4.0-5.0 amps. or resistance should be about 2.2-3.0 ohms. Excessive amperage draw or low resistance indicates shorted windings. If rotor tests okay, but alternator output is low, continue tests.

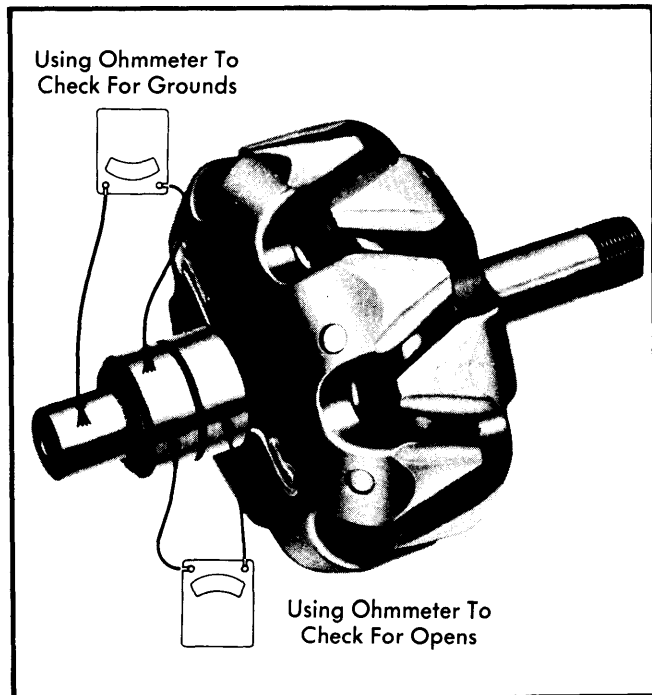

Fig. 5 Bench Testing Rotor for Opens or Grounds Using an Ohmmeter

Stator Checks for Grounds — Connect a 110 volt test lamp or an ohmmeter from any stator lead to stator frame. IF test lamp lights or if resistance is not infinity, stator is grounded and must be replaced.

NOTE — Delta windings on 15 SI and 27 SI series alternators cannot be checked for open circuits.

Stator Checks For Shorts — Refer to Fig. 7 and make test connections as shown using an Ohmmeter. **NOTE** — Ohmmeter should read in tenths (0.1) of an ohm. Results of all three tests should indicate equal resistance in all three winding phases. If not, a short exists and stator must be replaced.

Diode Trio — **NOTE** — One of two different diode trios may be used. Both are tested the same and can also be interchanged. With diode trio removed from end frame, connect an Ohmmeter to the single contact and to one of the three connectors. Observe reading, then reverse leads on the same con-

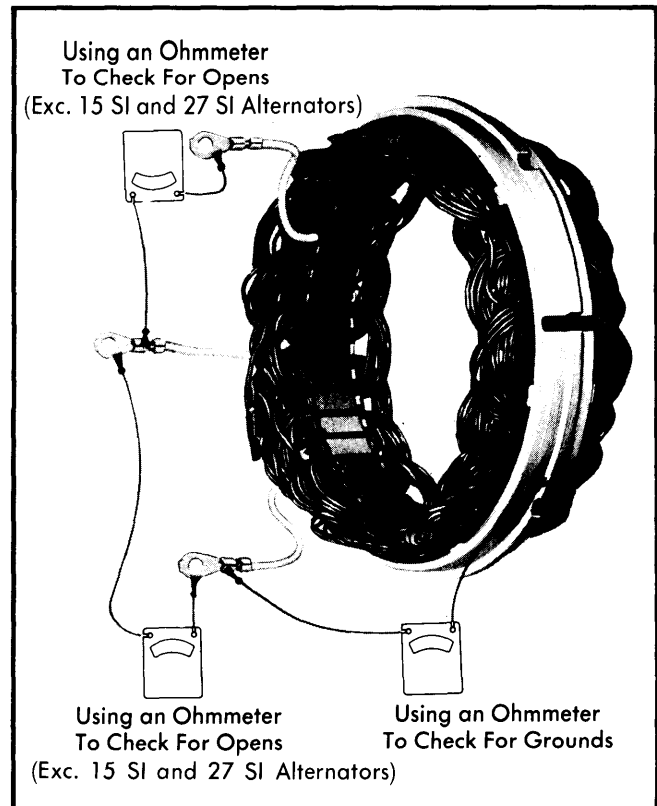

Fig. 6 Bench Testing Stator for Open or Grounded Circuits Using an Ohmmeter

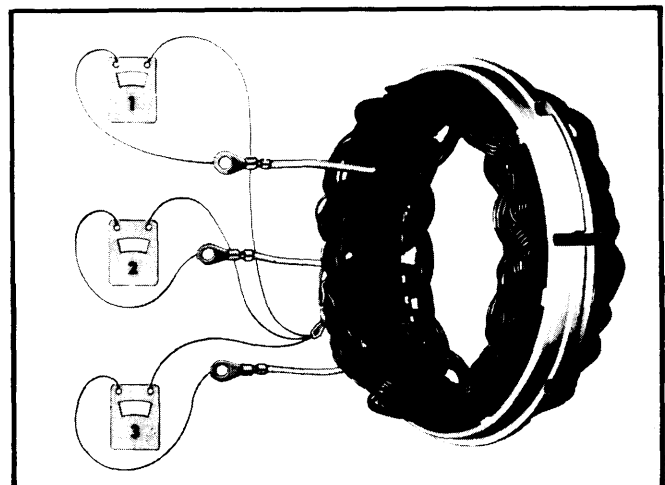

Fig. 7 Bench Testing Stator Windings for Shorts Using an Ohmmeter

nectors. A good diode trio will give one high and one low reading. If both readings are the same, replace diode trio. Repeat tests between single connector and each of the other two connectors.

NOTE — Before replacing diode trio, also check rectifier bridge. Do not use high voltage, such as 110 volt test lamp, to check diode trio.

DELCO-REMY WITH INTEGRAL REGULATOR (Cont.)

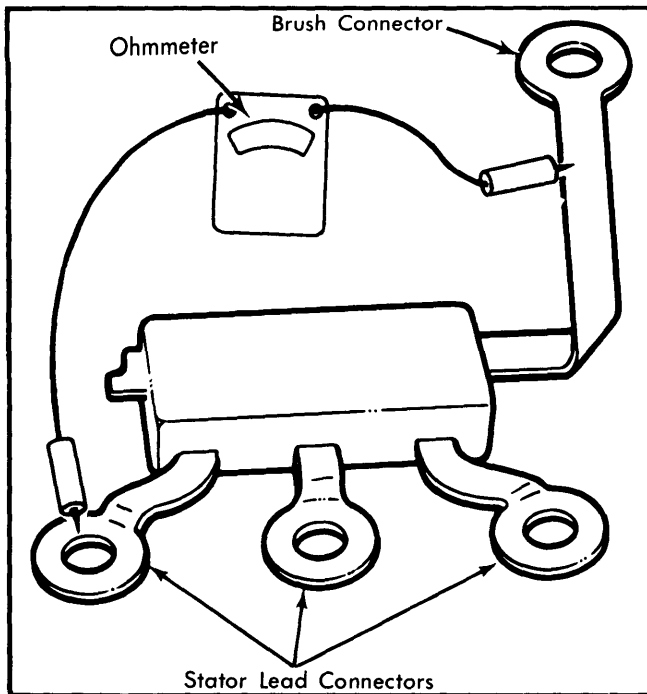

Fig. 8 Bench Testing Typical Diode Trio Using an Ohmmeter

Rectifier Bridge Check – Connect an Ohmmeter to the grounded heat sink and one of the three terminals. Then reverse lead connections to heat sink and same terminal. If both readings are the same replace the bridge. A good rectifier bridge will give one high and one low reading. Repeat test on all terminals. When this is done you will have checked all six diodes with two readings taken for each diode. Do not use high voltage such as a 110 volt test lamp to check bridge.

NOTE – Do not replace diode trio or rectifier bridge unless at least one pair of readings is the same.

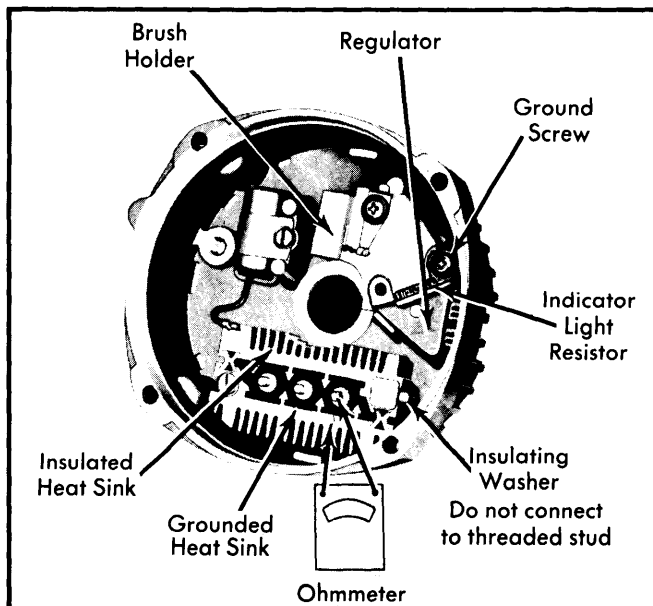

Fig. 9 Bench Testing Rectifier Bridge and Identification of End Frame Components

Voltage Regulator Brush Lead Clip Check – Connect an Ohmmeter from brush lead clip to end frame (see illustration). Then reverse leads, if both readings are zero, either the brush lead clip is grounded or the regulator is defective. A grounded brush lead clip can result from omission of the insulating washer, insulating sleeve on screw, or a damaged insulating sleeve. Remove screw and inspect insulating sleeve if it is satisfactory, replace regulator unit.

REASSEMBLY

1) Install rotor in drive end frame and attach spacer, fan and pulley. Using an Allen wrench, hold shaft and tighten nut. Install capacitor in slip ring end frame. Position brush holder and regulator assemblies in end frame, install retaining screws. Note the screws retaining brush clips have insulating washers over top of brush clips and special insulating sleeves over screw body above threads. Use wood or plastic toothpicks to retain brushes prior to installing slip ring end frame to drive end frame.

NOTE – When installing new bearing in 15 SI, support inside frame with a hollow cylinder to prevent breakage of end frame. Avoid misalignment or placing undue stress on the bearing.

2) Position rectifier bridge to end frame. Install attaching screw and "BAT" terminal screw. Connect capacitor lead to bridge. Position diode trio on rectifier bridge terminal and install screw attaching brush lead clip to brush holder. Insulating washer must be assembled over top of connector. Position stator in end frame. Connect stator leads to rectifier bridge terminals and install attaching nuts. Position slip ring end frame to drive end frame and install through bolts.

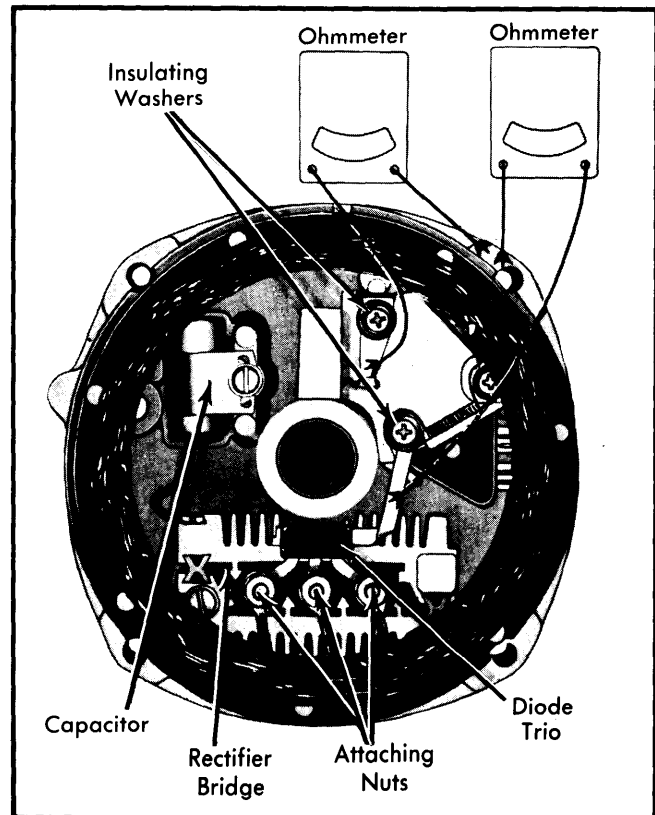

Fig. 10 Bench Testing Voltage Regulator Brush Lead Clips Using an Ohmmeter

Alternators & Regulators

DELCO-REMY WITH INTEGRAL REGULATOR (Cont.)

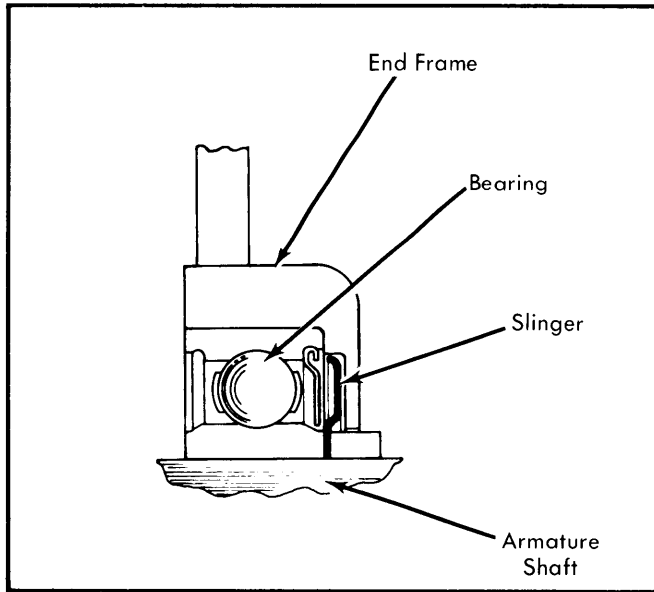

Fig. 11 Drive End Bearing Assembly
(10 SI and 27 SI Series)

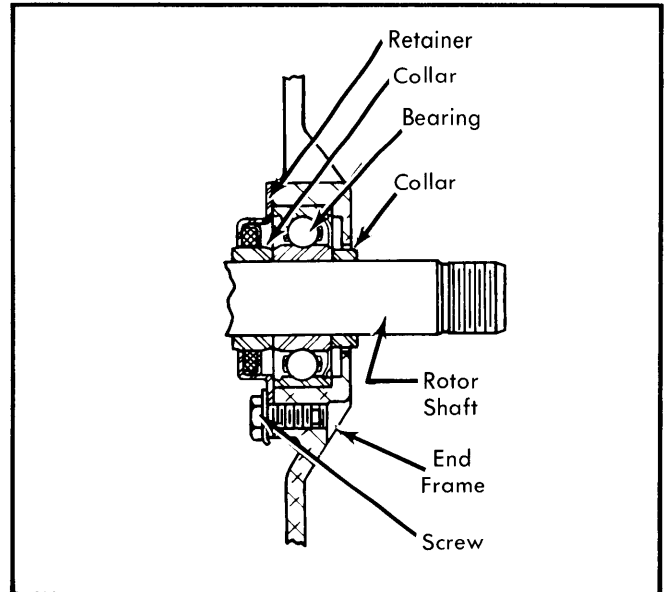

Fig. 12 Drive End Bearing Assembly
(15 SI Series)

| DELCO-REMY DELCOTRON SPECIFICATIONS | | | | | |
|-------------------------------------|-------------------------------------|------|-------|------|---|
| Stamped Rated Amp. Output | Test Specifications (At 14.0 Volts) | | | | Field Current (Amps.) 12 Volts @ 80°F |
| | Amps. | RPM | Amps. | RPM | |
| 37 | 22 | 2000 | 33 | 5000 | 4.0-4.5 |
| 42 | 25 | 2000 | 38 | 5000 | 4.0-4.5 |
| 55 | 30 | 2000 | 51 | 5000 | 4.0-4.5 |
| 61 | 30 | 2000 | 57 | 5000 | 4.0-4.5 |
| 63 | 32 | 2000 | 60 | 5000 | 4.0-4.5 |
| 80 | 55 | 2000 | 76 | 5000 | 4.0-4.9 |