

OLDSMOBILE**Oldsmobile
All Models (Exc. Starfire)**

NOTE — For Starfire, see General Motors "H" Body in this section.

DESCRIPTION & OPERATION

Fuel Gauge — Circuit consists of an electrical indicator in instrument panel and a float controlled rheostat in fuel tank. The raising and lowering of fuel in tank varies the circuit resistance through the rheostat, changing the indicator reading.

Temperature Indicator — When engine coolant temperature reaches 258°F (260" & 455" engines), 253°F (350" Omega), 260°F (L-6 engines with sender in thermostat housing), or 285°F (L-6 engines with sender in cylinder head), sending unit on engine will close the circuit to ground, allowing indicator lamp on instrument panel to light.

Oil Pressure Indicator — If engine oil pressure is not satisfactory, sending unit on engine will close completing the indicator lamp ground circuit. Oil pressure light should come on when ignition is on and engine is not running.

Alternator Indicator — Indicator light should be on when engine is not running and ignition is turned to "ON". Light should go off and remain off once engine has been started and accelerated above 900 RPM.

TESTING**FUEL GAUGE**

Insure battery is fully charged. Disconnect electrical lead at fuel tank sending unit. Connect gauge tester (BT-6508) to sending unit wire and to ground. Set tester at "FULL" and turn ignition to "ON" position. If gauge responds to tester, check sending unit ground. If sender ground is good, replace sender. If gauge does not respond to tester, leave sender disconnected and connect tester to left terminal of gauge (viewed from back of gauge) and to ground. If gauge responds to tester, check printed circuit. If gauge does not respond, replace gauge.

INDICATOR WARNING LIGHTS

Temperature Indicator — If indicator light remains on with engine running, check for excessive coolant temperature, a grounded wire between bulb and sending unit, or a defective sending unit or ignition switch. If light fails to come on when cranking engine, check for burned out bulb, open light circuit or defective ignition switch.

Oil Pressure Indicator — If light remains on when engine is running above idle speed, check for low oil pressure, a grounded wire between bulb and sending unit or a defective sending unit. If light fails to come on with ignition on and engine stopped, check for burned out bulb, open light circuit or a defective sending unit.

Alternator Indicator — If light comes on with engine running above idle RPM, check alternator output, check for a shorted alternator negative diode or loose or broken alternator belt. If light remains on when ignition is off, check for shorted alter-

nator positive diode. If light remains off when ignition is on but the engine is not running, check for burned out indicator bulb, an open light circuit or an open in alternator field.

STOP LIGHT SWITCH

If all stop lights fail to come on, or fail to turn off, check White wire terminal in turn signal connector using a test light, while depressing brake pedal. If test light fails to come on, check stop light switch adjustment. If adjustment is correct, replace stop light switch. **NOTE** — On Toronado, check relays to upper level tail lights before replacing stop light switch.

ADJUSTMENT**STOP LIGHT SWITCH**

Insert switch into tubular clip until switch body is seated. Pull pedal rearward until it contacts stop. Switch will move in clip for proper adjustment, allowing stop lights to be off with brake pedal in released position.

REMOVAL & INSTALLATION**INSTRUMENT PANEL PAD
88, 98 & TORONADO**

Remove panel lights, pry speakers from clips and disconnect wires. Remove pad screws from speaker cavities. Remove pad screws from lower left side, in glove box and above speedometer. Grasp front center edge of pad and pull to release from clips at windshield edge.

**INSTRUMENT PANEL COVERS
88, 98 & TORONADO**

Remove right hand cover before left hand cover. Remove cover end screws and pull cover from lower trim panel. Cover is retained by studs pushed through clips in trim panel.

**UPPER TRIM PANEL
88, 98 & TORONADO**

Remove panel pad and right hand panel cover. Remove glove box door and disconnect right hand air duct if equipped. Disconnect wiring from clock, trunk release and glove box light. Remove trim panel screws and panel. To install, reverse removal procedure.

**LOWER TRIM PANEL
88, 98 & TORONADO**

Remove panel covers. With air conditioning, disconnect lower outlet duct. Remove cigar lighter by pulling case out. Remove center vent if equipped and disconnect parking brake cable. Remove trim panel screws, lower panel, disconnect wires and remove trim panel.

HEADLIGHT SWITCH

88, 98 & Toronado — Remove heater or air conditioning controls. Remove headlight switch escutcheon using suitable tool (BT-6817-3). Pull switch through opening in panel to disconnect wiring. To install, reverse removal procedure.

Cutlass — Disconnect battery cable. Remove cluster pad assembly and two headlight mounting screws. Pull switch from panel and remove connector.

OLDSMOBILE (Cont.)

Omega — Disconnect battery cable. Put switch at "ON" position. Reach under instrument panel and depress the switch shaft retainer and remove shaft assembly. To install, reverse removal procedure.

WINDSHIELD WIPER/WASHER SWITCH

88, 98 & Toronado — Remove headlight switch. Remove wiper switch knob and fasteners. Pull switch through panel to disconnect wiring. To install, reverse removal procedure and reconnect ground wire.

Cutlass — Disconnect negative battery cable. Remove cluster pad assembly, switch mounting screws and remove switch from rearward. To install, reverse removal procedure.

Omega — Pull wire connector from rear of switch, remove screws and switch from rear of panel. To install, reverse removal procedure.

HEATER OR AIR CONDITIONER CONTROL

88, 98 & TORONADO

With heater only, disconnect defroster and temperature cables at heater. With air conditioning, remove lower trim panel and fastener attaching temperature cable to control. Remove headlight switch knob from shaft by releasing knob retainer. Remove applique from clips by prying under lower edge. Remove control assembly screws and disconnect hose and electrical connections. To install, reverse removal procedure. If necessary to adjust temperature control cable, adjust so knob has $\frac{1}{8}$ " spring back from right side.

INSTRUMENT CLUSTER

88, 98 & Toronado — Remove upper trim panel and panel covers. Disconnect upper left hand air duct. Disconnect temperature and defroster cables at heater. Remove nut from rear of radio support brace. Remove cluster screws and pull out to disconnect speedometer cable. Disconnect electrical connectors necessary to remove cluster. Disconnect vacuum hoses from temperature control units. Disconnect antenna lead-in, connector, and speaker connectors from radio. Carefully pull fiber optic element from lens. Disconnect harness fasteners and remove cluster from panel. To install, reverse removal procedures.

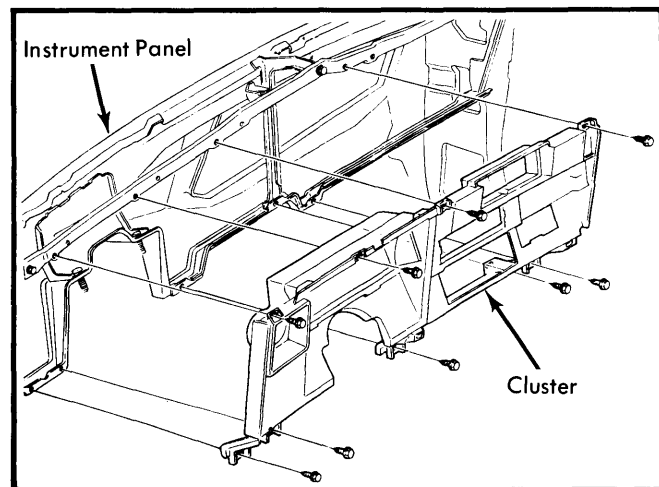

Fig. 1 Instrument Cluster Panel
(88, 98-Toronado Similar)

Cutlass — Remove speedometer cluster, fuel gauge and telltale cluster assemblies as follows: With column shift automatic transmission, remove lower trim cover below steering column and disconnect shift indicator clip on shift bowl. Disconnect speedometer cable. Lower steering column. Remove speedometer screws and pull speedometer out so shift indicator needle is not damaged; then disconnect wire connectors. To install, reverse removal procedure.

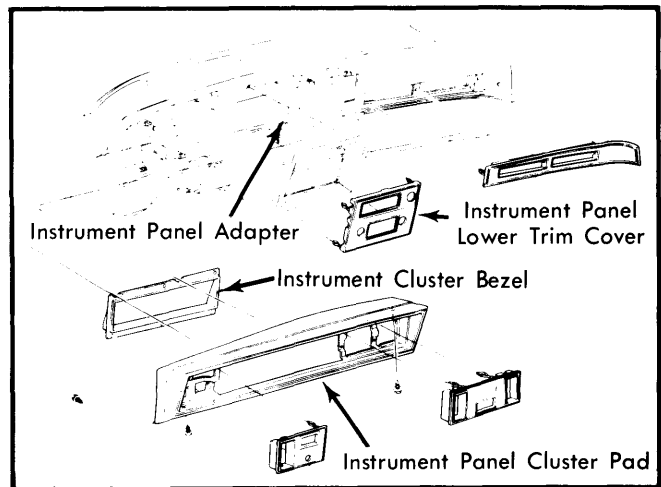

Fig. 2 Instrument Panel Trim Covers
(Cutlass)

Omega — With column shift automatic transmission, remove shift indicator needle from shift bowl. Lower steering column. Remove heater control panel screws. Remove radio knobs, bezel nuts and front support at lower edge of instrument cluster. Remove screws at top, bottom and side of cluster. Tilt cluster and reach behind to disconnect speedometer cable, speedometer, electrical connectors and remove cluster. To install, reverse removal procedure.

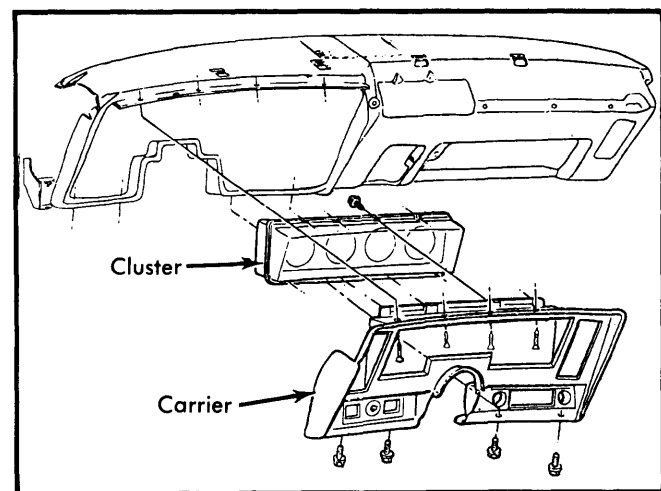

Fig. 3 Instrument Cluster Panel (Omega)

SPEEDOMETER & GAUGES

88, 98 & Toronado — Remove cluster lens screws and pull lens out at top and lift from bottom edge tabs. Remove screws and bezel from cluster. Lift face plate over shift indicator needle. Remove speedometer or gauge face screws, remove cable

OLDSMOBILE (Cont.)

or electrical connections and remove speedometer or gauge. To install, reverse removal procedure.

Cutlass — See *Instrument Cluster Removal & Installation*.

Omega Speedometer — Remove instrument cluster and screws retaining rear cover to cluster. Bend ground strap away and remove cover. Remove speedometer-to-housing retaining screws and speedometer from rear cover. To install, reverse removal procedure.

Omega Fuel Gauge — Remove instrument cluster and printed circuit. Remove gauge assembly from cluster housing, three terminal nuts attaching gauge to cover plate, then remove gauge. To install, reverse removal procedure.

PRINTED CIRCUITS

88, 98 & Toronado — Remove instrument panel pad, upper left side A/C hose, and main harness from printed circuit connectors and instrument panel flange. Position harness towards windshield. Remove light sockets and three nuts attaching low

fuel warning circuit board (if equipped) to main printed circuit. Lift low fuel circuit board from the studs, pull light sockets from cluster and remove warning system. Remove three studs from cluster. Remove low coolant warning circuit board (if equipped), by turning it 1/8 turn counterclockwise. Remove six screws retaining main circuit board to cluster, and pull lower edge of board down and outward to disengage it from tabs at top edge of cluster. To install, reverse removal procedure.

Cutlass — Remove speedometer printed circuit after removing speedometer cluster, light sockets from printed circuit and three retaining screws. Remove fuel gauge printed circuit or fuel economy meter (if equipped), after removing gauge assembly, light sockets from printed circuits, plastic cover and resistor, and printed circuit attaching screws or meter retaining nuts. To install, reverse removal procedure.

Omega — Remove instrument cluster, illumination and indicator lights, and terminal nuts from fuel gauge and clock which retain printed circuit to housing. Remove four screws retaining printed circuit board to housing and remove circuit board. To install, reverse removal procedure.