

# Sun & Moon Roofs — Electric

CHRYSLER CORP., FORD MOTOR CO., GENERAL MOTORS

## DESCRIPTION

Both Sunroof and Moonroof are operated by a two position switch, which is operable only with ignition switch on. When activated, sliding panel moves down and retracts rearward, moving on guide rails to storage place between headlining and roof. Sliding panel may be left partially open by releasing control switch at any position in either direction of travel.

## ELECTRICAL SYSTEM

**Chrysler Corp.** — Sunroof is actuated by a two-way electric motor mounted near center of windshield header area. Motor and wiring are protected by a circuit breaker.

**Ford Motor Co.** — Sun roof is actuated by a two-way electric motor mounted at center of windshield header area. Motor is operated by a two-way control switch on roof panel.

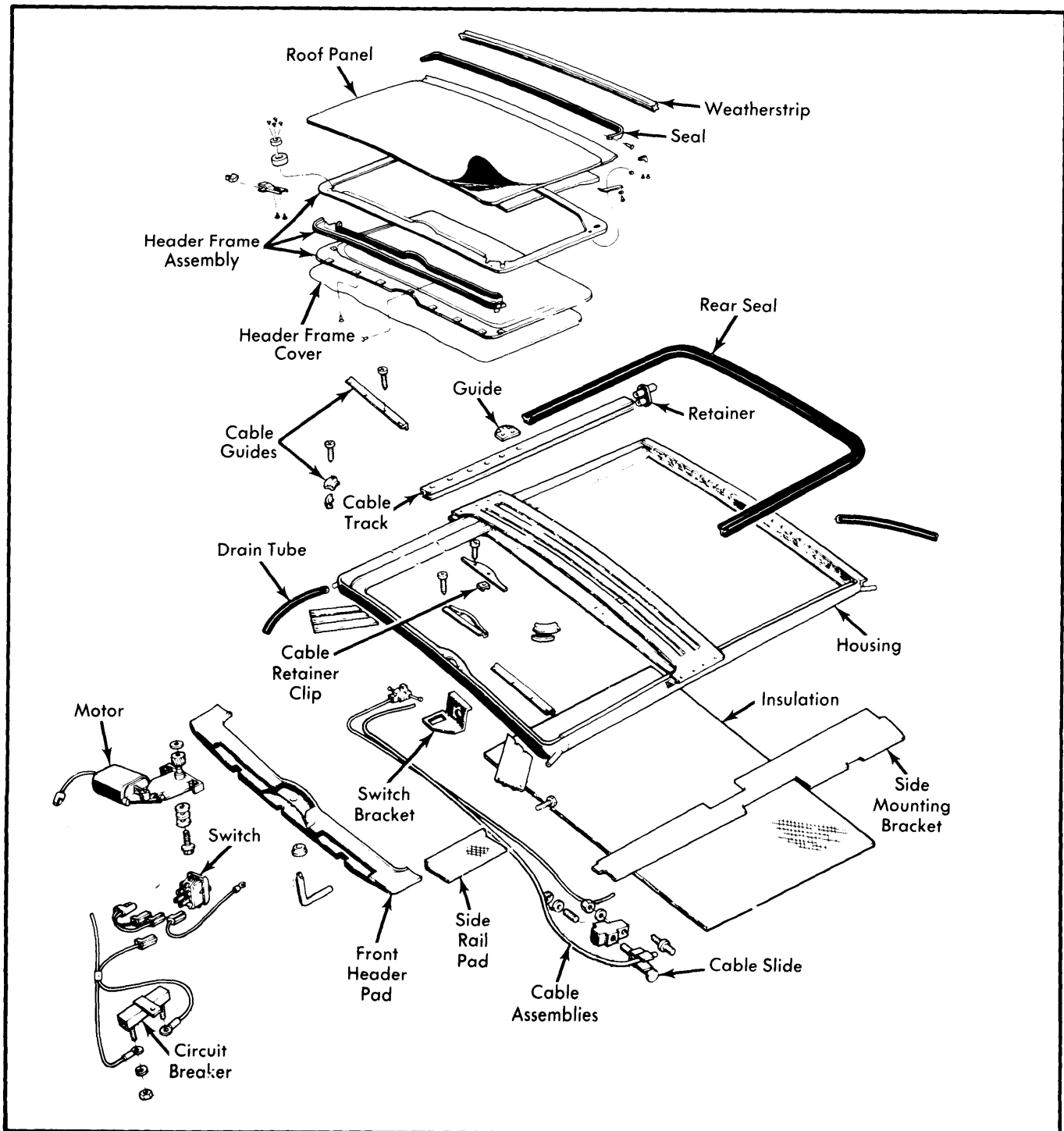

**Fig. 1 Exploded View of Sun Roof Assembly  
Moon Roof Assemblies Similar**

## CHRYSLER CORP., FORD MOTOR CO., GENERAL MOTORS (Cont.)

**General Motors** — Electric power is supplied from a fuse block mounted circuit breaker, then wiring leads to an accessory junction block and ignition relay. Wiring is then routed from relay up through left pillar and across headliner to control switch.

### MANUAL OPERATION

Sunroof can be closed manually in the event of power failure as follows: Remove auxiliary drive cover (small round plug in center of headliner near front edge of roof opening) by grasping with fingers and pulling outward. Using hex head auxiliary crank tool, remove Allen screw from motor drive assembly noting number and type of washers removed with the screw. Screw and washers provide drive clutch adjustment. Insert threaded end of crank in socket in winding gear, and turn crank clockwise to close sunroof. After closing, install screw with washers in proper order, tighten screw securely and replace plug.

### TROUBLE SHOOTING & ADJUSTMENT

#### SLIPPING CLUTCH

If motor runs freely and panel fails to close completely, clutch in auxiliary drive is slipping and requires adjustment. Remove auxiliary drive cover and tighten adjusting screw. If clutch still slips, remove screw and add washer(s), supplied with operating handle in glove box. Tighten screw and check operation.

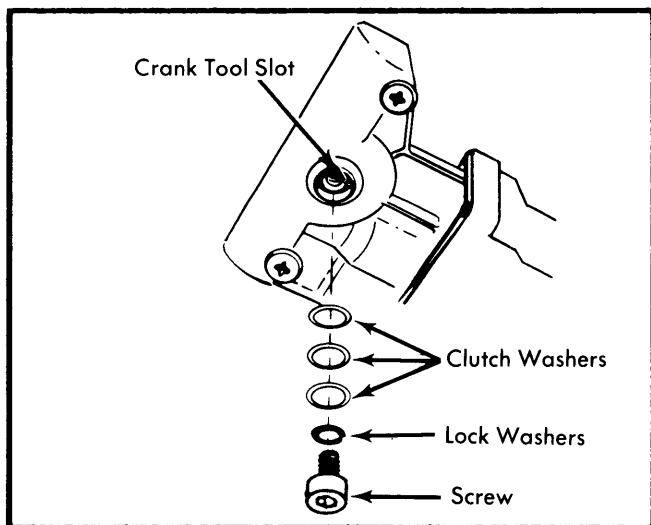

Fig. 2 Clutch Screw and Adjusting Washers

#### ROOF PANEL DOES NOT RUN TRUE

Close roof panel to determine side that jams. Open roof panel, remove drive housing center cover and pry off cable retaining clip. **CAUTION** — Clip is made of spring steel, hold hand over clip to prevent rapid spring up. To move right side forward, lift right cable at front of pinion and pull one or more teeth to left. Install retaining clip and drive housing cover, and check operation. Follow same procedure on left side to move left side forward.

**CAUTION** — DO NOT accidentally move panel while cable is off pinion.

#### CABLE GUIDE ALIGNMENT

If roof panel jams during operation, check both front corner lower cable guides for alignment with front and side guides. If necessary, shim lower corner guides for alignment with adjacent guides. If panel fails to rise, joints of cable slides are out of alignment and are jamming cable drive. Loosen guide rail, corner and connector rails, and cable drive housing retaining screws a few turns. Retighten screws one by one, continually activating the drive mechanism. Where necessary, realign points where resistance is felt.

### REMOVAL & INSTALLATION

#### MOTOR & DRIVE GEAR

**Chrysler Corp.** — 1) Remove visors and bracket, and upper front and side garnish moldings. Remove both left and right "A" post moldings. Pull switch bezel down gently to remove from header. Pull headliner down gently to remove from spurs and cemented area. Remove cable guide cover and drive cable retaining clip.

2) Remove front cable guide mounting screws (both left and right) and cable guide retainer. Remove fabric around motor mounting screws (if necessary). Disconnect both harness leads to motor, marking connectors and switch for correct installation. Remove motor mounting screws and remove motor from under header and lining. To install, reverse removal procedure.

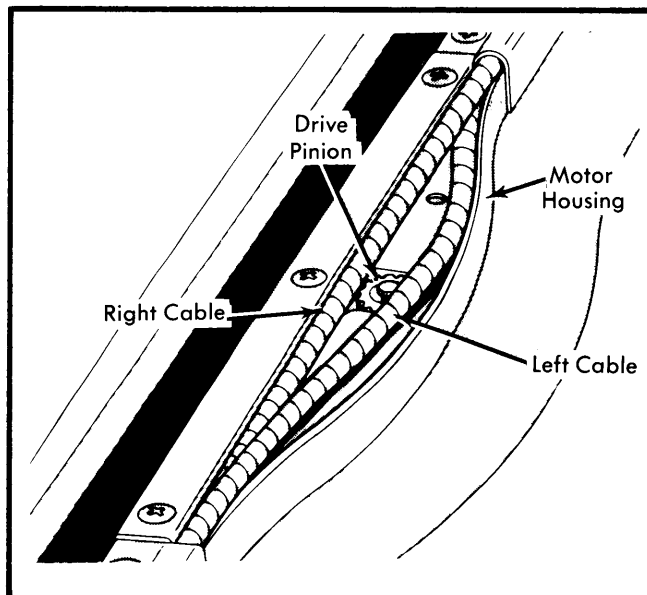

Fig. 3 View Showing Roof Drive Cable Removal

**Ford Motor Co.** — 1) Slide sunroof panel fully open and disconnect battery ground cable. Remove cable drive housing cover, drive cable retaining clip and disengage drive cables from pinion.

2) If only drive pinion is being replaced, remove snap ring flat washer and pinion from shaft. Install new pinion, secure with flat washer and snap ring. Re-engage cables to pinion, install retaining clip and cable drive housing cover.

3) Remove both sun visor assemblies, center bracket, motor and drive assembly. Pull control switch down from roof and remove windshield upper and side garnish molding and rail garnish moldings. To install, reverse removal procedure.

## CHRYSLER CORP., FORD MOTOR CO., GENERAL MOTORS (Cont.)

**General Motors** — 1) Open sunroof and disconnect battery cable. Disconnect headlining trim lace across front of sunroof opening and remove windshield garnish moldings, side rail garnish moldings, both sun visors and center sun visor bracket. Remove drive pinion cover button and access hole trim. Carefully grip control switch bezel and pull switch out from retainer in headlining.

2) Pull harness through opening and disconnect connector. Carefully detach headlining across front of sunroof opening and windshield header. Remove front cable guide cover and header pad. Remove electrical connectors from motor. Remove motor retaining screws and remove motor from under header lining. To install, reverse removal procedure. **NOTE** — Before installing motor, check sunroof alignment with opening and adjust as necessary.

## SLIDING PANEL, HALO MOULDING OR SUN SHADE

**Chrysler Corp.** — Remove panel headlining and trim molding. Remove both left and right front guides. Pry spring loaded guide pin out of mounting in sunroof panel and remove rear cable guide assemblies. Raise panel slightly and remove leaf spring from slider spool on rear guide assembly. Remove panel out through top of roof. To install, reverse removal procedure.

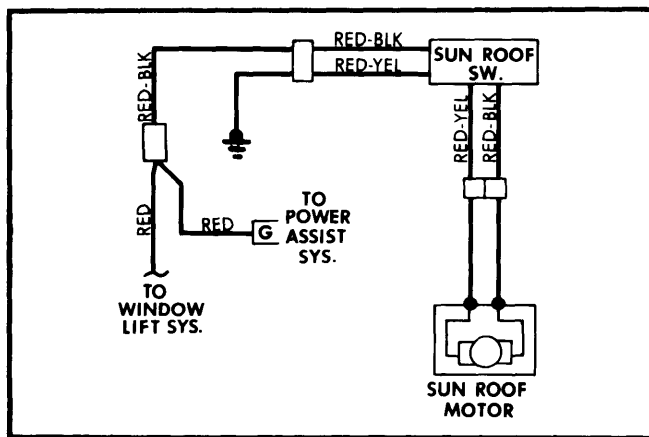

Fig. 4 Chrysler Corp. Sunroof Wiring Diagram

**Ford Motor Co.** — 1) If equipped with Moon Roof, halo moulding must first be removed. Push sun shade to rear and open roof panel half way. Remove screws on forward portion of moulding.

2) On Lincoln and Mark V, lower front edge of halo moulding and cycle sliding panel fully closed. Turn halo moulding sideways and down to remove.

3) On all models except Lincoln & Mark V, cycle roof to a nearly closed position. Pull the forward center of halo moulding downward until the horizontal tabs are removed from track. **NOTE** — Place a shop towel over front horizontal tabs to prevent them from tearing headliner. Cycle roof to fully closed position. Slide moulding forward. Pull rearward on center section so horizontal track slide is removed from track. Slide halo moulding forward and out. To install halo moulding, reverse removal procedure.

4) To remove the sun shade on Lincoln and Mark V, place sliding panel in rearmost position (with halo moulding removed). Pull shade forward, bow shade upward at center, then lift shade out of tracks.

5) To remove sun shade on all models except Lincoln and Mark V, first remove halo as previously described and sliding panel as follows, then from outside the vehicle push center of shade upward to disengage shade from track and slide shade forward and out of vehicle.

6) To remove sliding panel (metal or glass) first remove halo moulding. Detach sliding panel from both left and right front slide assemblies by removing outboard retaining screw from guide shoe. Loosen inboard screw, rotate guide shoe so slide portion is disengaged from track, then proceed as follows.

7) On Lincoln, Mark V, Versailles, Thunderbird and Cougar, rotate rear slide tension springs to inboard position to release them. Detach panel from rear slide assemblies by removing the two retaining screws (hex nuts on Thunderbird and Cougar) and removing mounting bracket to panel retainers from both tabs in panel.

8) On all except above models, grasp panel rear retainer pins and slide pins inboard to disengage from pivot bracket. Rotate pins away from pivot bracket and from outside of vehicle, remove sliding panel.

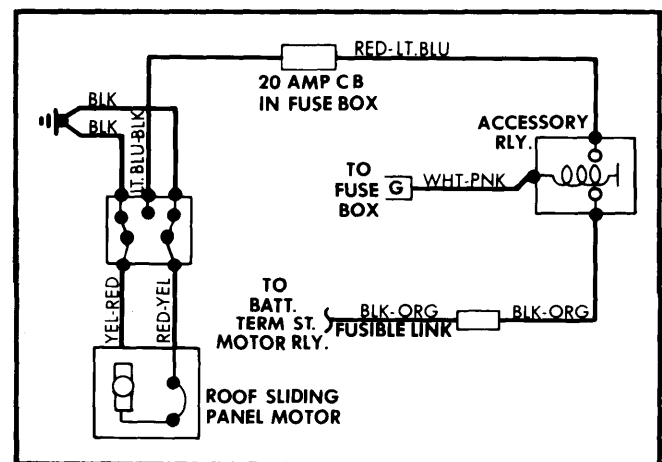

Fig. 5 Ford Motor Co. Moonroof Wiring Diagram

**General Motors** — 1) If equipped with Astrorooft, halo moulding must be removed first. Slide sunshade completely to rear and open roof panel half way. Remove three screws on forward portion of halo moulding. Close roof panel to within 3" of fully closed position and deflect front center of halo moulding down so that tabs at front of moulding are removed from track mechanism. Fully close roof and slide molding forward. Deflect center rear of molding so track slide surface is removed from track. Slide halo moulding forward to remove.

2) On regular sunroof models, open roof panel slightly and pry down front portion of headlining panel. Open sunroof to within 3" of fully open position to allow headlining frame to fall free of roof panel rear hooks. Pull headlining panel forward out of side guide rail tracks. Close sunroof and push headlining panel as far rearward as possible.

## CHRYSLER CORP., FORD MOTOR CO., GENERAL MOTORS (Cont.)

3) On all sunroof models, remove outer and loosen inner retaining screws at both front guide shoe assemblies. Rotate guide assemblies so that slide portion is disengaged from track. Pull both rear slide and cable assemblies inward and out of retainer hole. Lift and remove sunroof up and out through top of vehicle. To install, reverse removal procedure.

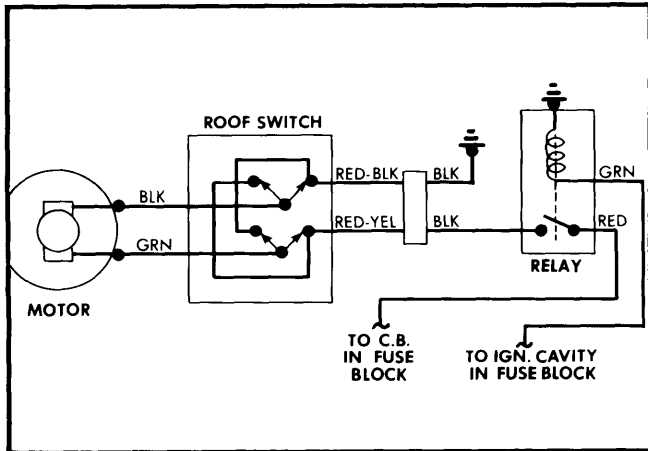

Fig. 6 General Motors Sunroof Wiring Diagram

### REAR GUIDE AND CABLE ASSEMBLY

**Chrysler Corp.** — 1) Remove sliding panel headlining, front trim panel, and sliding panel as previously described.

2) Remove left and right corner tracks and center cable retainer cover. Pry off drive cable retaining clip.

**CAUTION** — Clip is made of spring steel. Hold hand over clip for protection when removing.

3) Free cables from pinion gear and slide cable and rear guide forward until its free of side tracks. Remove assembly out of front cable guides.

4) To install, reverse removal procedure installing the left cable first and using the fifth side track screw from front as a cable centering guide. Lubricate cables at areas of corner tracks and drive pinion teeth with Lubriplate or equivalent grease.

**NOTE** — Both cables must be replaced even though only one cable is defective to assure parallel travel of roof panel.

**Ford Motor Co.** — 1) Remove halo moulding and sliding panel as previously described. Remove front cable cover and side track retainers on Lincoln, Mark V, Versailles, Thunderbird and Cougar, or remove cable drive cover plate, track extension, and corner cover housing on all other models.

2) On Lincoln, Mark V, Versailles, Thunderbird and Cougar, remove cable retainer at drive gear (two screws) and slide cable assembly forward and out of track. On all other models, remove cable retainer clip, lift cable from drive housing, and slide cable forward and out of side track.

**NOTE** — If required, remove track retaining screws and lift track so cable will slide out.

3) To install, reverse removal procedure. To insure proper initial alignment, pull cables as far forward as possible before laying them in the track and securing them to drive gear.

**General Motors** — 1) Remove motor, drive gear, and sliding panel as previously described. Disconnect trim lace and headlining at sides of roof panel opening.

2) Working at top edge of sunroof opening, remove screws retaining each side guide rail, front stop, and front guide cover.

3) Remove center cable guide. Disengage side guide rail from front guide rail. Pull rear guide and cable assembly forward out of side guide rail. Remove opposite cable in same manner.

4) To install, reverse removal procedure after lubricating cables and channels at front cable guides. To insure proper alignment, pull both cable and guide assemblies against the ramps (rear edge) of side guide rail retainers before installing cable center guide.