

Seat Controls — Electric

GENERAL MOTORS

DESCRIPTION

Power seats are operated by toggle type switches on the left side of the seat or in the left door arm rest. Seat adjusters are actuated by a 12 volt reversible motor with an internal circuit breaker. An external 30 ampere plug-in type circuit breaker is also used to protect power seat wiring and is mounted on fuse panel.

OPERATION

2-Way Seats — These seats operate in forward and rearward directions only. Control switch energizes motor and at each end of the motor shaft is a jack screw which turns the seat adjusters in the desired directions through a horizontal gear nut attached to the seat adjuster.

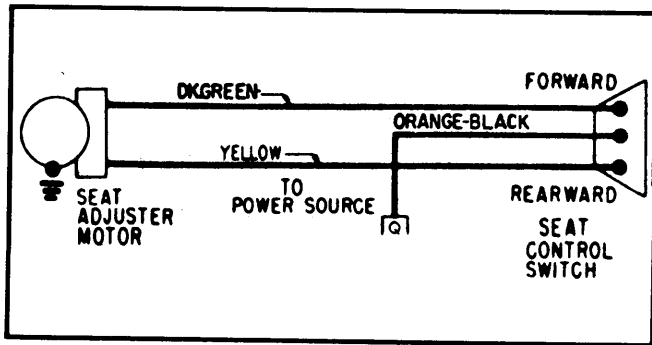
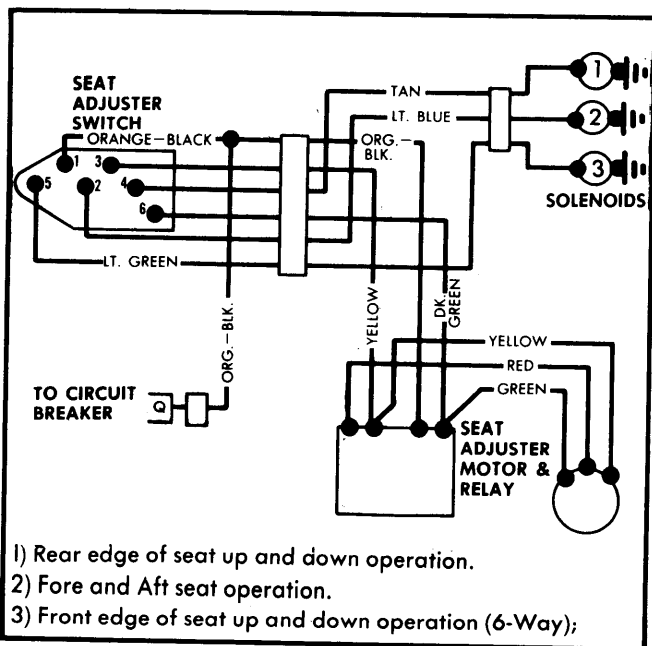

Fig. 1 2-Way General Motors Power Seat Wiring Diagram

6-Way Seats — Operating mechanism consists of a transmission assembly which incorporates three solenoids and six drive cables to seat adjusters. One solenoid controls front of seat vertical movement, second controls horizontal movement and third controls rear vertical movement. When the control



- 1) Rear edge of seat up and down operation.
- 2) Fore and Aft seat operation.
- 3) Front edge of seat up and down operation (6-Way);

Fig. 2 6-Way General Motors Power Seat Wiring Diagram (Exc. C-69 Style Cadillac)

switch is actuated, a double contact first energizes solenoid selected engaging plunger dog and driving gear, then motor is energized. The solenoid driving gear rotates drive cables and operates both seat adjusters moving seat in desired direction.

NOTE — 6-Way Seats for Cadillac Brougham (6CB69 style) use a different seat adjuster assembly. Assembly is basically the same but uses different parts. Removal and installation are the same as the standard seat adjuster assembly.

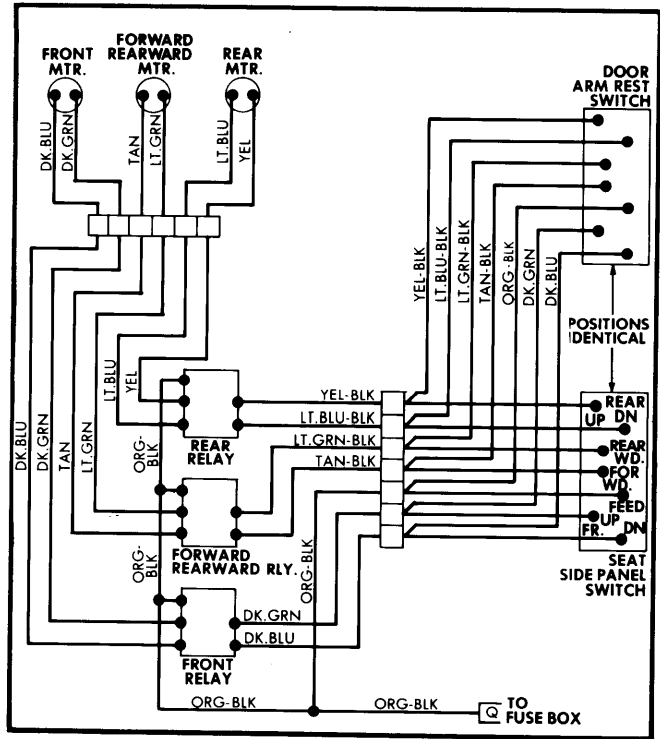

Fig. 3 6-Way General Motors Power Seat Wiring Diagram (Cadillac C-69 Styles Only)

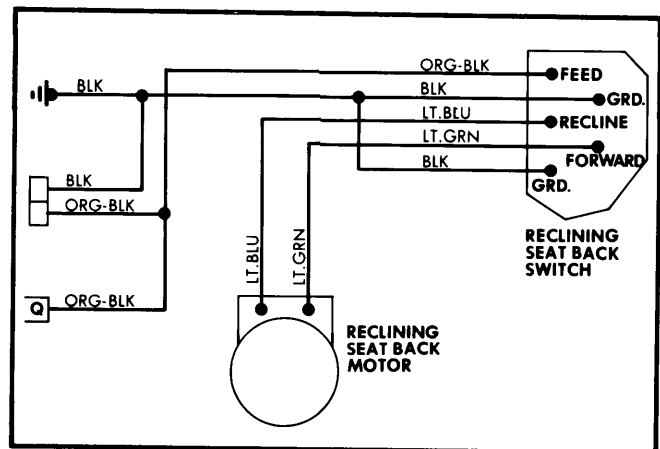

Fig. 4 General Motors Power Reclining Seat Back Wiring Diagram

Power Reclining Seat Back — Available in all Cadillacs (exc. Limousine) and Buick LeSabre, Riviera, and Electra models. Electrically the power reclining seat back system consists of a

GENERAL MOTORS (Cont.)

permanent magnet motor, relay assembly and a three position switch. This function is additional to the 6-way power seat system. Switch is located at the outboard side of the seat cushion or front door arm rest, and can be used in conjunction with seat control switch.

TROUBLE SHOOTING

MECHANICAL

Jerky Horizontal Operation – Improper lubrication of adjuster shoes and channels. Adjuster shoes too tight in upper channels.

Horizontal Chuck or Looseness – Horizontal actuator improperly adjusted.

One Adjuster Will Not Operate Horizontally – Horizontal drive cable damaged or disconnected. Horizontal actuator inoperative.

One Adjuster Will Not Operate Vertically – Vertical drive cable disconnected or damaged. Vertical gear nut inoperative.

Vertical Chuck or Looseness – Excessive clearance at vertical gear nut tension spring.

ELECTRICAL

Inoperative Adjuster Motor – Check for shorted or open circuit between power source, switch, and/or motor. Check for a defective motor.

Motor Operates But Adjusters Will Not Operate – Check for a shorted or open circuit between switch and solenoid. Check solenoid for defects.

Motor Operates But Adjusters Or Recliner Only Operate In One Direction – Check for a shorted or open circuit between one of the motor fields and control switch. Check for a defective field coil.

ADJUSTING

Horizontal Actuator Adjustment – Chucking can be corrected by adjusting the horizontal actuator and pinion gear to full mesh with the lower adjuster lower track rack-gear as follows:

Operate seat to full up position, and approximately a 3/4 full forward position. Loosen horizontal actuator screws.

Using a large screw driver as shown in illustration, apply outward pressure on horizontal actuator (about 15-25 lbs.) and at the same time energize horizontal switch to move seat fore and aft slightly. This helps seat the horizontal actuator pinion gear teeth tight to the lower track rack gear teeth and eliminate free play between gear teeth. While maintaining outward pressure against horizontal actuator, tighten actuator screws.

If chucking or looseness is found during vertical movement, grind down top of vertical gearnut shoulder nut $\frac{1}{4}$ " to $\frac{3}{4}$ " maximum.

REMOVAL & INSTALLATION

SEAT ASSEMBLY

All Seats – Remove seat belt-to-floor anchor plate attaching bolts. Where required, remove door sill plates and turn carpet to gain access to adjuster-to-floor pan attaching bolts.

Operate seat to full forward and up position. At rear of adjusters, remove adjuster-to-floor pan rear attaching bolts. Operate seat to full rearward and full rear tilt position. Remove front adjuster-to-floor pan nuts. Disconnect all electrical wire harnesses under seat and remove seat. To install, reverse removal procedure.

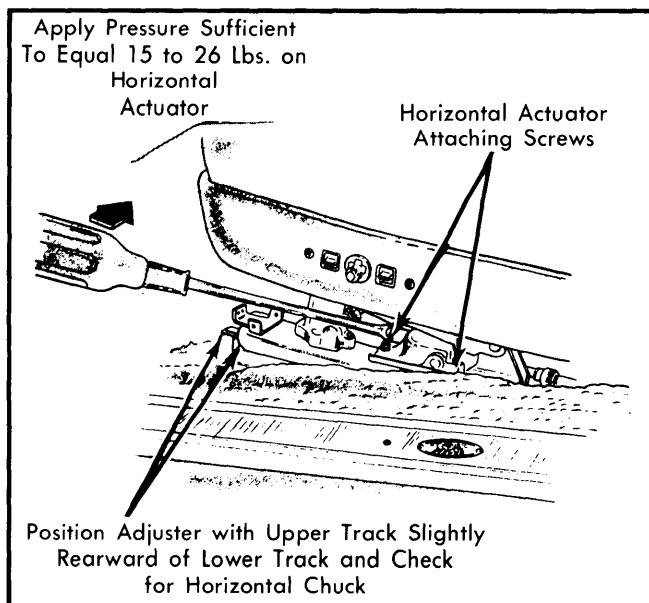

Fig. 5 Horizontal Actuator Adjustment

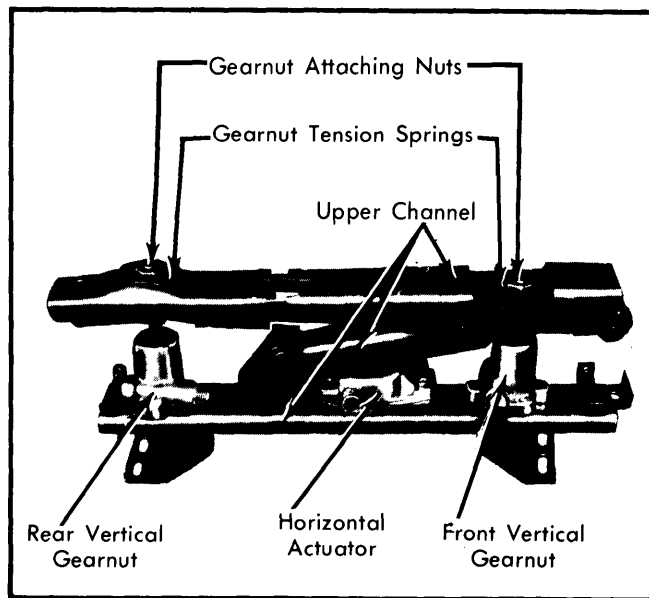

Fig. 6 6-Way Seat Adjuster Mechanism

SEAT ADJUSTER ASSEMBLY

All Seats – Remove seat as outlined above. Place seat upside down on bench. Disconnect drive cables at adjuster being removed; squeeze oblong connector to detach. On bucket seats, remove bolt securing motor and transmission support to adjuster being removed. Remove adjuster-to-seat bottom attaching bolts and remove seat adjuster. To install, reverse removal procedure, checking to be sure seats are in "phase".

GENERAL MOTORS (Cont.)

SEAT BACK RECLINING ACTUATOR

Remove seat as outlined above. Detach outboard side of seat cushion cover to gain access to front and rear actuator attaching bolts. Remove bolts from actuator and remove actuator from cushion frame. To install, reverse removal procedure.

SEAT ADJUSTER PHASING

All Seats (Exc. Seat Back Recliner) — When installing power seat adjusters, each pair of adjusters must be in "phase" with each other. When adjusters are out of phase, one adjuster will reach its maximum travel before the other, resulting in improper travel of seat.

Horizontal Travel — Operate seat until one adjuster reaches full forward position. Detach horizontal drive cable from adjuster which has reached full forward position. Now operate seat forward until other adjuster reaches full forward position. Reconnect drive cable of early adjuster. Adjusters are now in phase.

Vertical Travel (Front or Rear) — Operate seat until one adjuster has reached fully raised position at both front and rear vertical travel limits. Disconnect both front and rear vertical drive cables from adjuster which has reached fully raised posi-

tion. Operate seat until other adjuster reaches fully raised position. Now reconnect cables of early adjuster. Seat should now be in phase, if not repeat the above procedure.

DRIVE MOTOR

2-Way Seat — If seat is operable, operate seat to a midway position. Remove front seat adjuster-to-floor pan attaching bolts and tilt seat rearward. Remove power drive cables from motor. Disconnect motor wiring. Remove screws that secure motor support bracket to seat bottom frame and remove motor with bracket attached. Disassemble motor and bracket as a bench operation. To install, reverse removal procedure.

6-Way Seat — Remove front seat assembly. Place seat on bench upside down. Disconnect motor feed wires from motor control relay. Remove motor and transmission support-to-seat frame attaching bolts. Remove motor-to-support screws and then move motor assembly outboard away from transmission to disengage motor from rubber coupling. To install, reverse removal procedure.

Reclining Seat Back — Remove seat and place upside down. Remove trim on outboard side of seat for access to the actuator. Unscrew reclining back drive cable from reclining actuator and detach cable from actuator. Remove pin securing reclining actuator coupling to hinge arm and remove actuator. To install, reverse removal procedure.