

## CHRYSLER CORP. WINDOW DEFOGGER GRID

### DESCRIPTION

Heated rear window system consists of a window with an electrically heated grid baked on inside of glass. A control switch and continuous relay is used on Fury, Monaco, Charger Magnum and Cordoba. A control switch and a timer relay is used on all other models.

### OPERATION

Heated rear window system is controlled by a three position switch with "ON", "OFF" and "NORMAL" positions. Switch is spring loaded and returns to center ("NORMAL") position from either "ON" or "OFF" positions. When switch is turned "ON", voltage is applied to rear window grid and indicator light. When switch returns to "NORMAL" position, sufficient current is provided to hold relay coil energized and relay contacts closed. On vehicles with timer relay, electric current remains on for approximately ten minutes. On vehicles with continuous relay, electric current remains on until control switch or ignition is turned "OFF".

### TESTING

**NOTE** — Omni & Horizon wiring diagrams are not the same, but grid test procedures and voltages are the same.

**System Test** — 1) Check that in-line fuses or circuit breakers are operational and supply power. With rear window grid lines disconnected, turn ignition switch on and check voltage at relay terminals. Terminals "B" and "Y" should have voltage and terminals "L" and "P" should not have voltage (see Fig. 1).

tarily short terminals "B" and "P". Test light should come on and stay on after short is removed for 8.5-11.5 minutes if it has a timer or continuous if it does not.

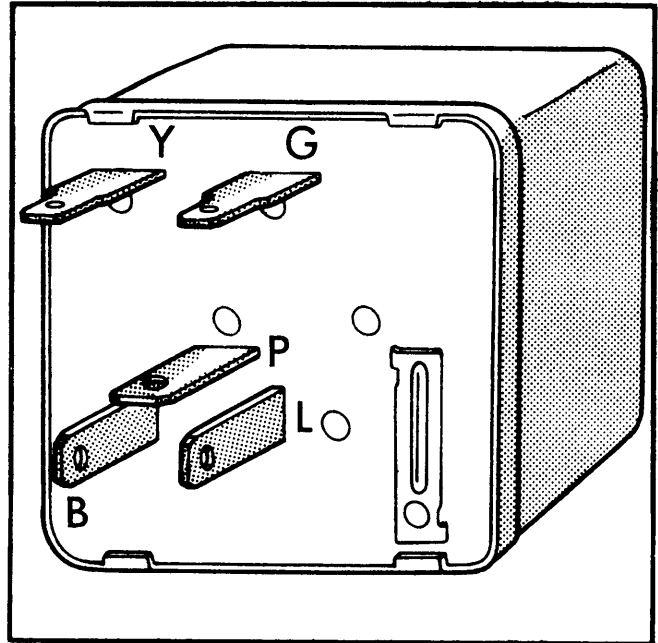

Fig. 2 Timer Relay Connections  
Omni & Horizon

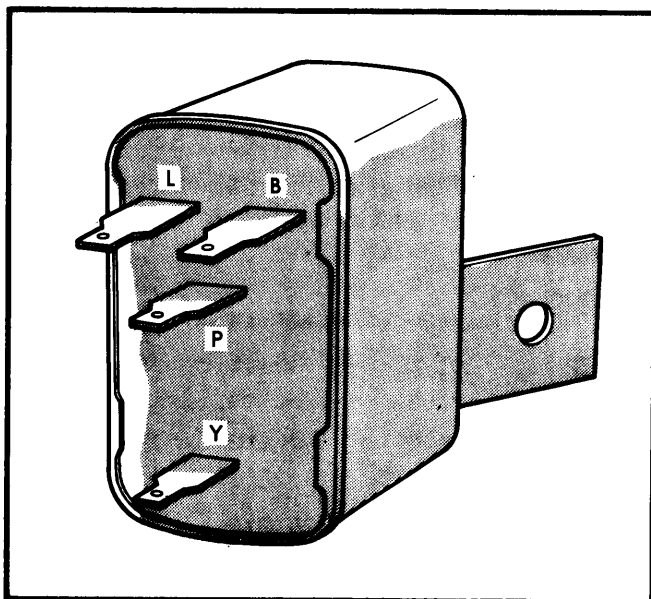

Fig. 1 Timer Relay Connections  
(Exc. Omni & Horizon)

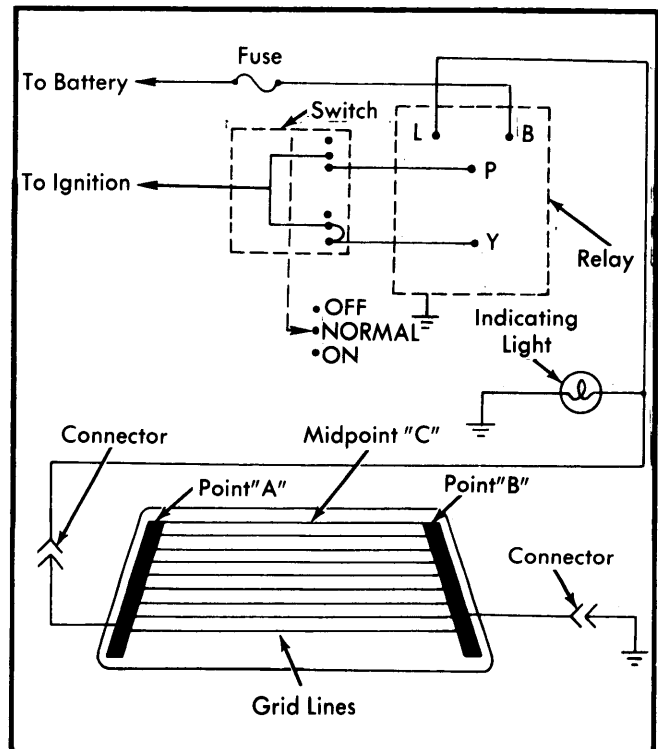
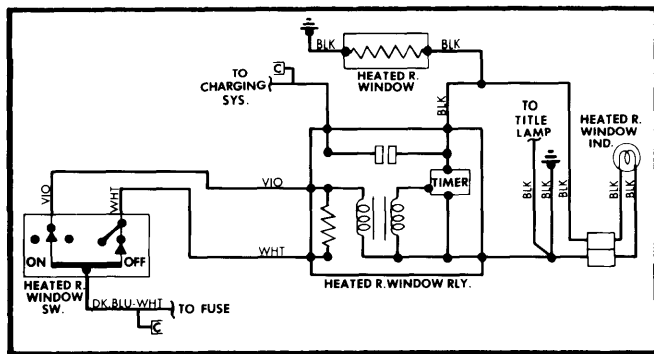

Fig. 3 Chrysler Heated Rear Window Wiring  
Diagram (Exc. Omni & Horizon)

2) Unplug relay and ground case. Connect a jumper wire between terminals "B" and "Y" and a 12 volt test light between terminal "L" and ground. Apply voltage to terminal "B". Test light should not light, if it does replace relay. Momen-

# Defoggers — Rear Window

## CHRYSLER CORP. WINDOW DEFOGGER GRID (Cont.)



**Fig. 4 Omni & Horizon Heated Rear Window Wiring Diagram**

3) Disconnect switch wires. With switch in "NORMAL" position, there should be continuity between two terminals. With switch "ON" there should be continuity between all terminals. With switch "OFF" there should be no continuity between terminals.

4) If system still does not operate, check leads and grid lines at rear window. Turn ignition and control switches on, attach a voltmeter between points "A" and "B" (see Fig. 2). Voltage reading should be 10-14 volts, if lower, check ground connections. With voltmeter connected at "B", measure grid voltages at midpoint "C". Voltage should be approximately six volts, a reading of zero volts indicates a break between point "A" and midpoint "C". A reading of 12-13 volts indicates a break between midpoint "C" and "B".