

MOTORCRAFT

American Motors
Ford Motor Co.

DESCRIPTION

Four pole, four brush starter with three series of coils and one shunt coil. Shunt coil is wound around a movable pole piece which operates the integral positive engagement drive mechanism.

TESTING

STARTER CRANKING CIRCUIT TESTS

Before performing tests, remove and ground coil secondary wire (disconnect at distributor.). Place transmission in neutral or park and apply parking brake. Be sure battery is fully charged. When making voltmeter connections, be sure to connect leads to battery posts or threaded terminals and not just to cable ends.

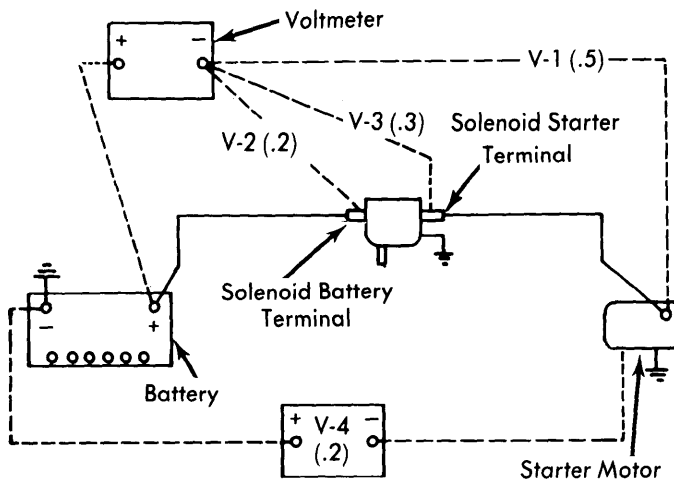

Fig. 1 Starter Cranking Circuit Test Connections

Battery-to-Starter Motor Voltage Drop (V-1) — Connect voltmeter positive lead to battery positive post and negative lead to starter motor terminal. While cranking engine, note voltmeter reading. Reading should be .5 volt or less. If reading is greater, move negative lead to starter cable and retest. If voltage is now .5 or less, remove cable and clean connections, then retest at starter motor terminal. If voltage is still above specifications, test individual cables between battery and starter as follows:

Battery-to-Solenoid Voltage Drop (V-2) — Connect voltmeter positive lead to battery positive post and negative lead to battery terminal of solenoid. While cranking engine, note voltmeter reading. Reading should be .2 volt or less. If reading is greater, remove cable and clean connections, then retest. If reading is still greater, replace cable.

Solenoid Voltage Drop (V-3) — Connect voltmeter positive lead to battery positive post and negative lead to starter CABLE at solenoid. While cranking engine, note voltmeter reading. Reading should be .3 volt or less. If reading is greater, move negative lead to starter TERMINAL at solenoid and retest. If reading is now .3 volt or less, remove and clean cable connector, then retest. If still in excess of .3 volt, replace solenoid. If battery-to-starter circuit (V-1) reading is now greater than .5 volt, replace solenoid-to-starter cable.

Starter Motor Ground Voltage Drop (V-4) — Connect voltmeter negative lead to starter motor housing and positive lead to battery negative post. While cranking engine, note voltmeter reading. Reading should be .2 volt or less. If more, move positive lead to ground cable attaching bolt at engine and retest. If reading is now less than .2 volt, check starter motor for loose mounting bolts, corrosion, or dirt on mounting surface. If reading is now more than .2 volt, examine ground cable for bad connections or bad cable.

STARTER LOAD TEST

Make connections as shown in illustration. Crank engine with ignition coil secondary wire grounded and note voltage on tester. Stop cranking engine and turn load control knob until voltage reading is exactly the same as it was when engine was cranking. Read current draw on ammeter scale. If not within specifications, starter is defective and must be overhauled.

NOTE — Do not take amperage draw reading until starter has obtained maximum RPM.

Load Test Specifications

Application	Amperes
American Motors All Models (4")	180-220
Ford 4" Starter	150-200
4 1/2" Starter	150-180

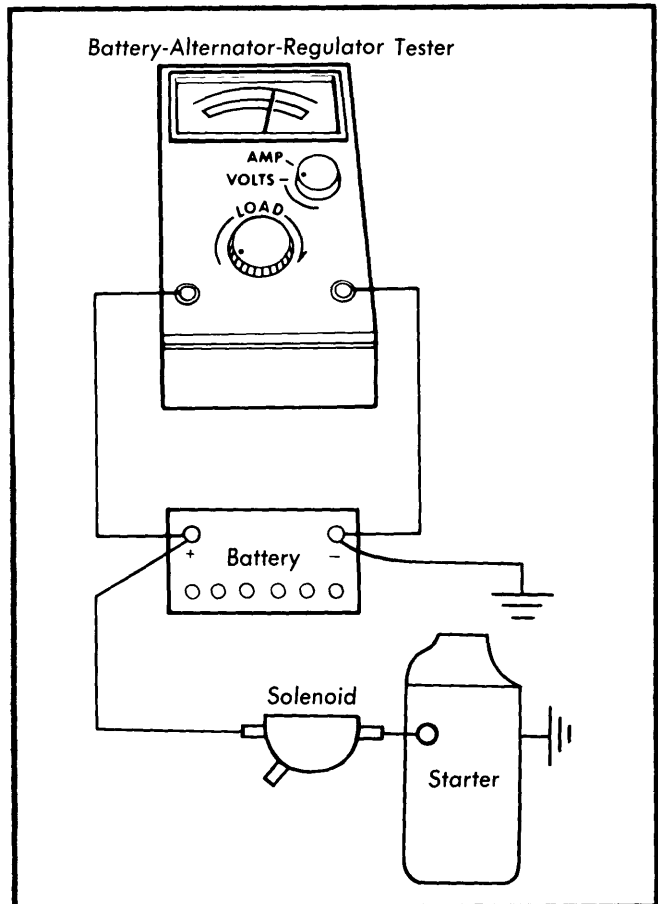

Fig. 2 Starter Load Connections

MOTORCRAFT (Cont.)

STARTER NO-LOAD TEST

Make connections as shown in Fig. 3 (also connect a tachometer to starter). Operate starter motor and note voltage reading and tachometer reading. Disconnect starter from battery. Turn load control knob until voltage reading is same as when starter is connected. Read the amperage drawn. If amperage reading is less than 65, starter has high electrical resistance. If starter RPM is less than 9000, worn bushings or bent armature is indicated.

Starter No-Load Test

Application

Specifications

Voltage	12 volts
Amperage	67-80 amps.
RPM Range	6700-10,843

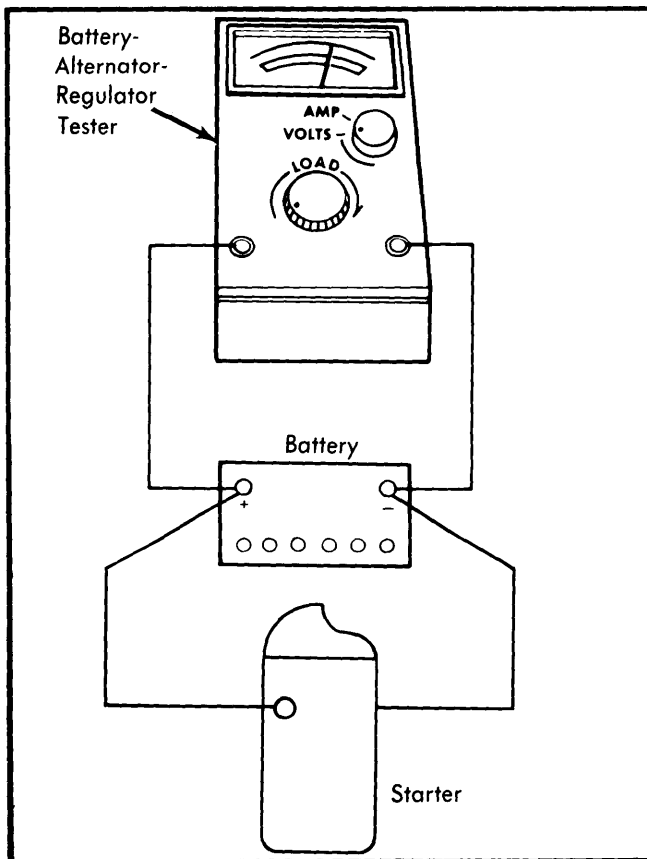

Fig. 3 Starter No-Load Test Connections

OVERHAUL

DISASSEMBLY

1) Remove brush cover band and starter drive lever cover. Remove brushes from brush holders (Note lead positions for assembly). Remove through bolts, starter drive end housing and starter drive plunger lever return spring. Remove actuating lever pivot pin. Remove lever and slide armature out.

2) Remove stop ring retainer. Remove and discard stop ring retaining starter drive gear to end of armature shaft, then remove starter gear assembly. Remove brush end plate. Remove screws retaining ground brushes to frame. Bend tab up on field coil (which operates drive gear actuating lever) retaining sleeve, remove sleeve.

3) Remove coil retaining screws. Unsolder field coil leads from terminal screw, remove pole shoes and coils from frame. Unsolder insulated brush leads from field coils. Remove starter terminal nut, washer, insulator and terminal from starter frame.

CLEANING

Use a brush or compressed air to clean field coils, armature, brush end plate, drive end housing and starter drive. Wash other parts in suitable solvent.

PARTS REPLACEMENT & TESTING

Armature - Check armature for shorted coils with a growler. Test for grounded coils with a test lamp or voltmeter and battery connected in series, by touching one test probe to commutator and other test probe to core or armature shaft. If test lamp lights, or voltmeter shows any reading, coils are grounded. Commutator should be clean and smooth. If commutator is burned or out-of-round more than .005", turn down in a lathe and sand lightly with 00 sandpaper.

Field Coil - Check for open or grounded coils with test lamp or voltmeter and battery connected in series. Make sure insulated brush leads are clear of frame, block drive coil contacts (on frame) open by inserting insulator between contacts, disconnect holding coil ground lead from frame. Touch one test probe to coil lead, other probe to frame. If lamp lights or voltmeter shows a reading, coils are grounded. Test for open coils by placing one test probe to field terminal and other probe to insulated brush lead. Lamp should light or voltmeter should show reading.

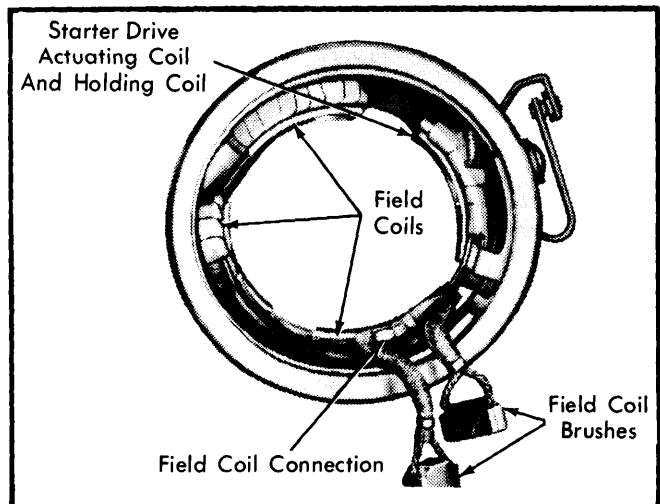

Fig. 4 Field Coil Assembly

Brushes & Springs - Check brush holders for broken springs and insulated brush holders for shorts to ground. Tighten any loose rivets. Replace brushes if worn to 1/4 in length.

MOTORCRAFT (Cont.)

Brush Spring Tension

Application	Tension
4" Starter	40 ozs.
4.5" Starter	80 ozs.

REASSEMBLY

1) Install starter terminal, insulator, washers and retaining nut.

NOTE — Position slot in screw perpendicular to frame end surface.

Position coils and pole pieces (with coil leads in terminal screw slot), install retaining screws. As screws are tightened, strike frame several times with soft faced hammer to seat and align pole shoes, then stake screws.

2) Install solenoid coil and retainer and bend tabs to retain coils to frame. Solder field coils and solenoid wire to starter terminal using rosin core solder. Check for continuity and grounds in assembled coils. Position new insulated brush leads on field coil terminal (use clip provided with brushes to hold brush lead to terminal), solder lead, clip, and terminal with rosin core solder.

3) Position solenoid coil ground terminal over nearest ground screw hole, place both ground brushes into starter frame and install retaining screws. Position commutator end plate on frame with end plate boss in frame slot. Apply thin coating of Lubriplate on armature shaft splines; install drive assembly on shaft and install new stop ring and retainer. Position fiber thrust washer on commutator end of armature and position armature in starter frame.

NOTE — Fiber thrust washer is not used with molded commutator armatures.

4) Position starter drive gear plunger lever to frame and starter drive assembly; install pivot pin. Partially fill drive end housing bearing (about 1/4 full) with grease. Position drive plunger lever return spring and drive end housing to frame; install and tighten through bolts to 55-75 INCH lbs. Do not pinch brush leads between plate and frame. Make sure stop ring retainer is seated properly in drive housing.

5) Install brushes in brush holders, centering springs on brushes. Position drive gear plunger lever cover on starter and install brush cover band with a gasket. Tighten band retaining screw. Check starter no load current draw.

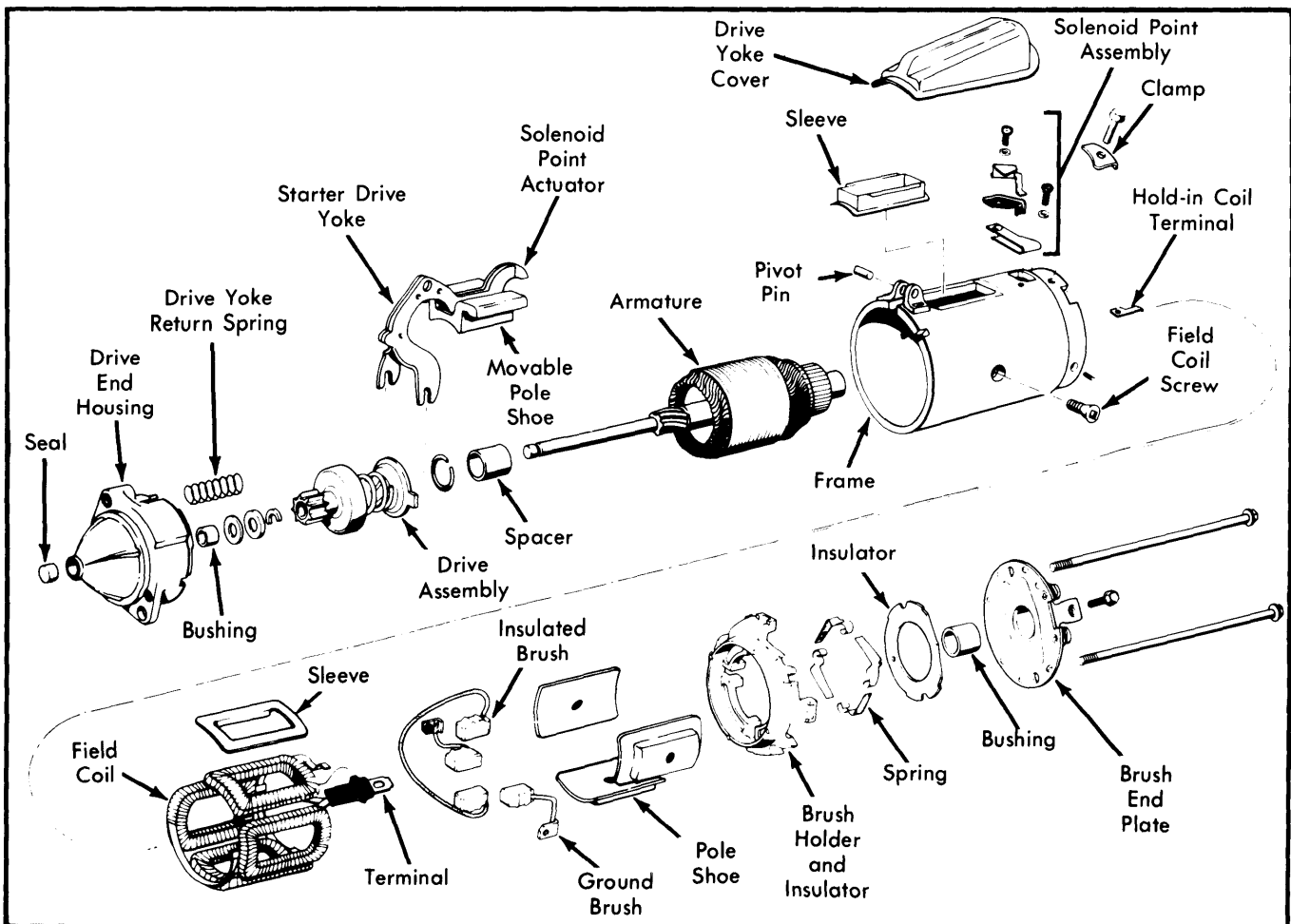

Fig. 5 Exploded View of Starter Motor Assembly