

FORD MOTOR CO.

Ford Motor Co.
All Models

DESCRIPTION & OPERATION

Ammeter Gauge — Gauge is a shunt-type which senses direction and rate of electrical current (amperage) to or from the battery, indicating whether battery is being charged or discharged.

Alternator Indicator — Indicator light will come on when field relay contacts are open. With ignition on and engine not running, battery current flows through the indicator light and 15 ohm parallel resistor, and through the regulator voltage limiter contacts to the field. The light will remain on until the engine is started and the alternator builds up enough voltage to close the field relay contacts, at which time the light will go out.

Fuel Gauge — Gauge pointer is operated by current flow heating a wire wound bi-metal strip in gauge. Current flow is controlled by a variable resistor float type sending unit in the fuel tank. As the amount of fuel decreases, more resistance is placed in the circuit, allowing less current flow and heat at the bi-metal strip, causing pointer to move a shorter distance.

Low Fuel Indicator — This warning system consists of an electronic sensor/switch device, located on relay above glove box, and an indicator light in instrument panel. Switch is controlled by the difference in voltage potential between the two terminals of fuel gauge. When tank is less than one-quarter full of fuel, switch is closed by the difference in voltage potential, turning on the indicator light. The indicator should also come on, but for less than one minute, when the ignition is turned to the "ON" position. **NOTE** — *Electronic sensor/switch can not be tested or repaired, but indicator circuit can be tested.*

Instrument Voltage Regulator — IVR is used in conjunction with all gauges (exc. ammeter). It controls and maintains an average pulsating value of five volts at gauge. A suppression choke is connected in series between printed circuit and IVR to prevent radio interference.

Oil Pressure Gauge — Oil pressure gauge circuit consists of an IVR, oil pressure gauge and a pressure operated sending unit. As oil pressure increases, resistance in sending unit decreases causing an increase in current flow and gauge pointer movement.

Oil Pressure Indicator — The light is connected between the oil pressure sending unit and the coil terminal of the ignition switch. Light should come on when ignition switch is turned to the "ON" position or when oil pressure is not above the prescribed pressure. **NOTE** — *On models with an "ENGINE" warning light, disconnect temperature switch lead before testing the oil pressure indicator circuit.*

Temperature Gauge — System consists of a variable resistance type sending unit and a gauge. As coolant temperature increases, resistance in sending unit decreases allowing an increase of current flow and gauge pointer movement. It is possible, under certain driving conditions, for pointer to read at the top of the normal band and still have coolant temperature within limits.

Temperature Indicator — System consists of a "TEMP" or "ENGINE" light and a normally open-to-ground temperature sensing switch. When coolant temperature reaches ap-

proximately 245° F, switch closes circuit to ground, turning on the indicator light. As a test of proper bulb operation, the light will also turn on with the ignition in the "START" position.

NOTE — *On models with Automatic Temperature Control type air conditioning systems, the temperature sending unit has two terminals. The terminal marked "R" (gauge equipped) or "C" (indicator light equipped) provides a ground circuit for cold engine override (below 125°F engine temperature) of heater blower motor.*

TESTING

GAUGES

Oil Pressure Gauge — Remove oil pressure sender unit and temporarily attach a mechanical oil pressure gauge in its place. Operate engine to determine oil pressure. If engine oil pressure is normal, instrument cluster gauge should also indicate normal pressure. To test oil pressure gauge and IVR proceed as follows: Disconnect gauge lead from terminal at sender unit. Connect lead of a 12 volt test light or positive lead of a voltmeter (20 volt scale) to lead that was disconnected from sender unit. Connect other test lead to a good ground. With ignition on, a flashing light or fluctuating voltmeter indicates IVR is operating properly and gauge circuit is not interrupted.

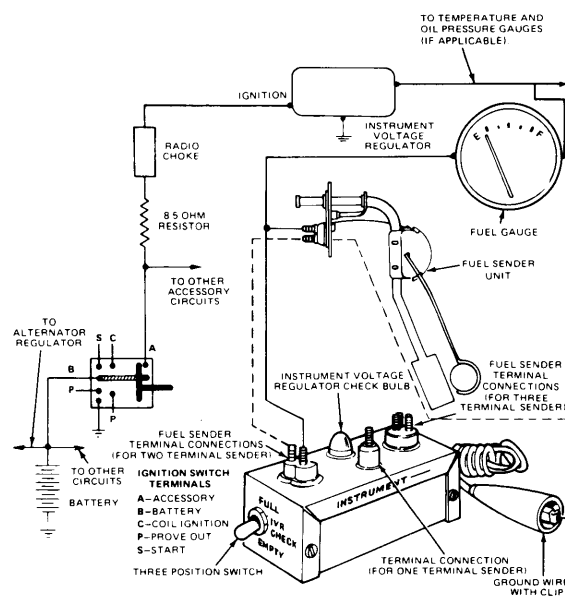

**Fig. 1 Testing IVR and Fuel, Oil, or Temperature Gauge
Fuel Gauge Test Shown**

If pulsating voltage is shown but gauge is not accurate, perform calibration test. If light stays on or voltage reading is steady replace IVR. If no voltage is indicated by voltmeter or test light, check for an open circuit in IVR, gauge windings, or printed circuit. Do not spark or ground either terminal of IVR. This could burn out dash wiring harness or IVR, or both.

Oil Pressure Gauge Calibration Test — When instrument voltage regulator or gauge is suspected of being out of calibration, having a fluctuating movement, or high or low pressure, both the gauge and IVR must be tested simultaneously. This test is done on the vehicle.

Test equipment consists of a 22.8 ohm resistor to check gauge calibration for correct mid scale readings, and a 73 ohm resistor to check for low scale readings.

FORD MOTOR CO. (Cont.)

Disconnect lead from gauge at sender unit, connect resistor between gauge lead and ground. Turn on ignition. With the 22.8 ohm resistor gauge should show a mid scale reading. With the 73 ohm resistor, gauge should show a low scale reading.

If gauge does not perform as prescribed, replace IVR and retest. If gauge now (with new IVR) reads correctly problem is solved. If gauge is still out of calibration it is defective and must be replaced.

Oil Pressure Gauge Bench Test — To test gauge for open windings; remove gauge from cluster. Connect gauge to ohmmeter and read resistance. An upward movement of needle from 10 to 14 ohms is normal because current increases the temperature of gauge coil windings. If ohmmeter reads below 10 ohms or above 14 ohms, replace gauge.

Ammeter — Turn headlights on, engine off. Meter pointer should move toward the "D" or discharge side of the gauge. If no pointer movement is noted check the following: Rear of meter housing for loose connections, printed circuit connections, multiple connector at printed circuit. If connections are good replace ammeter. Should ammeter pointer move toward "C" with lights on and engine off, ammeter connections are reversed. This is most likely to occur in an ammeter system that uses a wiring harness rather than a printed circuit.

Fuel Level Indicator — Disconnect wiring connector from terminals at sender unit. Check terminals for possible corrosion or undercoating, and clean as necessary. Connect the lead of a 12 volt test light, or positive lead of a voltmeter to gauge lead that was disconnected from sender. Connect other test lead to a good ground. With ignition on a flashing light or fluctuating voltmeter will indicate instrument voltage regulator is operating and that gauge indicator circuit is not interrupted. If light stays on, or voltage reading is steady, replace IVR. If no voltage is indicated by meter or test light, check IVR for proper ground, or open circuit across IVR. Do not ground or spark either terminal of IVR, this could burn out dash wiring harness of IVR, or both.

Fuel Level Indicator Calibration Test — When instrument voltage regulator or gauge is suspected of being out of calibration, having a fluctuating movement or a high or low reading, both the gauge and IVR must be tested simultaneously. This test is done on vehicle.

Test equipment consists of a suitable fuel system tester (WRE-500-70) if available, or a pair of 10 and 73 ohm resistors, or another fuel sender of known good quality.

If test is performed with resistors: Disconnect wiring connector at sender unit, connect the resistor between the gauge lead and a suitable ground. Turn ignition on. With the 10 ohm resistor, the gauge should read on or above FULL. With the 73 ohm resistor, the gauge should read on or below EMPTY.

If test is performed with a good fuel sender: Disconnect wiring connector from sender and connect it to substitute sender, be sure sender is grounded. Turn ignition on, move float rod against full stop position (away from fuel filter). The gauge should read on or above FULL mark. With float against empty stop, gauge should read on or below EMPTY mark.

If gauge performs as indicated, replace sender unit. If gauge does not perform as indicated, replace IVR and retest to determine if gauge is causing trouble. If gauge now (with new IVR) reads correctly, problem is solved. If gauge is still out of calibration, gauge is defective and must be replaced.

Fuel Sender — To test sender on or off the vehicle, connect one lead of ohmmeter to ground terminal of sender unit (or sender housing on single terminal units), and other lead to resistor terminal of sender unit. With tank empty (on vehicle) or float rod against "EMPTY" stop (off vehicle), ohmmeter should read between 60 and 86 ohms. Slowly fill tank with fuel (on vehicle), or move float rod to "FULL" stop (off vehicle). Resistance reading should decrease smoothly from between 60 and 86 ohms, to between 8 and 12 ohms when tank is full or float rod contacts "FULL" stop. Slowly drain tank or return float to empty. Again resistance change should be smooth and return to previously specified resistance. If resistance specifications are not met at either position, or if resistance jumped between readings, replace sending unit.

Temperature Indicator — During tests, do not apply 12 volts directly to temperature sender terminal or sender unit will be damaged. Place a thermometer in coolant in radiator filler neck. Start engine and allow to run until thermometer reads a minimum of 180°F. Instrument panel gauge should indicate within normal range.

To test gauge proceed as follows: Disconnect gauge lead from terminal at sender unit. Connect lead of a 12 volt test light or positive lead of voltmeter (20 volt scale) to gauge lead that was disconnected from sender unit. Connect other lead to a good ground, turn ignition on. A flashing light or fluctuating voltmeter indicates instrument voltage regulator is OK and gauge circuit is not interrupted.

If a pulsating voltage is shown but gauge is not accurate perform a calibration test. If light stays on, or voltage reading is steady, replace IVR. If no voltage is indicated by voltmeter or test light, check for an open in IVR, gauge windings, or printed circuit. Do not spark or ground either terminal of IVR, as this could burn out dash wiring or IVR, or both.

Temperature Gauge Calibration Test — When gauge is suspected of being out of calibration, having a fluctuating movement or high or low readings, both gauge and IVR must be tested simultaneously. This test is done on vehicle.

Test equipment consists of a 10 ohm resistor to check gauge calibration for correct high readings, and a 73 ohm resistor to check for correct low scale readings.

Disconnect lead from gauge at sender unit, connect resistor between gauge lead and ground. Turn ignition on; with 10 ohm resistor, gauge should read within ½ pointer width on either side of "H" graduation. With 73 ohm resistor, gauge should read within ½ pointer width on either side of "C" graduation.

If gauge does not perform as prescribed, replace IVR and retest. If gauge now (with new IVR) reads correctly problem is solved. If gauge is still out of calibration it is defective and must be replaced.

INDICATOR WARNING LIGHTS

Alternator Indicator — Disconnect voltage regulator connector and turn ignition to "ON". Connect a test light (a No. 67 or 1155 bulb recommended) between regulator connector "I" terminal and regulator base. Test light will come on if circuit is good. If indicator warning light comes on at full brightness and test light fails to come on, 15 ohm resistor or circuit is open.

Oil Pressure Indicator — **NOTE** — On models which have an "ENGINE" warning light, disconnect temperature indicator sending unit lead but do not allow lead to contact ground.

FORD MOTOR CO. (Cont.)

Turn ignition to "ON" position. If indicator fails to come on, ground sending unit lead. If light comes on, check sending unit contact with engine or replace sending unit. If light fails to come on with lead grounded, check bulb and/or circuit for open condition.

Temperature Indicator — **CAUTION** - Never apply 12 volts directly to sending unit and be sure oil pressure sending unit lead is disconnected and not touching ground. If light remains on with ignition "ON", remove lead to sending unit. Connect an ohmmeter between sending unit terminal and engine (ground). If meter reads infinite, sender is OK. If meter reads zero, replace sender. If light is off with ignition in "START", check bulb and/or check for an open circuit between sender, bulb, and ignition switch.

Low Fuel Indicator — Turn ignition to "ON" position. Indicator light should come on, but for less than one minute if tank is more than one-quarter full of fuel. If indicator remains on, or if indicator does not turn on when tank is less than one-quarter full of fuel, perform the following checks at the wiring harness-to-switch connector. Terminal one is blank. Connect self-powered test light between terminal two and ground, then between terminal three and ground. Test light should blink at both terminals, but light should be brighter at terminal three. Test light should remain on when connected between terminal four and battery positive post; and also remain on when connected between terminal five and ground. When a jumper wire is connected between terminal six and battery positive post, indicator light should turn on and remain on. If any test fails, repair open circuit in wire to that particular terminal. If all terminals test good, make fuel gauge and IVR calibration test. If gauge and IVR calibration test is good, replace low fuel warning sensor/switch and retest.

REMOVAL & INSTALLATION

WINDSHIELD WIPER SWITCH

Ford, Mercury & Mark V — Disconnect battery ground cable. On Mark V, remove cluster finish panel as described under Instrument Cluster Removal and Installation. On all models remove wiper/washer and headlight switch control knobs, headlight switch bezel and trim panel. Remove wiper switch retaining screws and wiring harness connector. On Mark V, remove nut attaching switch to mounting plate. Remove wiper/washer switch. To install switch, reverse removal procedure.

Lincoln Continental, Thunderbird, Cougar & LTD II — Disconnect battery ground cable. Remove wiper switch knob. Remove bezel nut. Pull switch out of panel from underneath panel. Disconnect wiring and remove switch. To install, reverse removal procedure.

Maverick, Comet, Pinto & Bobcat — Remove instrument cluster as described in this story. Remove wiper switch knob and bezel nut. Pull switch out of mounting hole. Disconnect wiring and remove switch.

Mustang, Granada, Monarch & Lincoln Versailles — Remove wiper switch/turn signal arm from steering column using an internal driver bit (T-20) or Allen wrench to remove the retaining screw. The wiper switch is integral with turn signal switch and can not be repaired separately.

HEADLIGHT SWITCH

Ford & Mercury — Disconnect battery ground cable. Remove windshield wiper switch knob. Pull headlight switch knob out to "ON" position. From under instrument panel press and release button on switch housing and pull knob and shaft from switch. Remove bezel nut from switch. Remove lower finish panel attaching screws. Pull out on bottom of finish panel and remove switch plate to panel mounting screws. Disconnect switch wiring harness and disconnect illumination light from harness. Disconnect vacuum hoses to switch (if equipped). Remove light switch from mounting plate. To install, reverse removal procedure.

Mustang — Disconnect battery ground cable. Through access hole in underside of instrument panel, press and release button on switch and pull out knob and shaft from switch. Remove bezel nut. Lower switch, disconnect wiring and remove switch. To install, reverse removal procedure.

Pinto & Bobcat — Disconnect battery ground cable. Remove instrument cluster as described in this story. Remove switch knob and shaft and bezel nut. Disconnect wiring and remove switch from cluster opening. To install, reverse removal procedure.

Thunderbird and Mark V — Remove cluster trim panel as described under Instrument Cluster Removal and Installation. Remove bezel nut and disconnect switch wiring and vacuum lines. Remove switch. To install, reverse removal procedure.

LTD II, Cougar, Maverick, Comet & Lincoln Continental — Disconnect battery ground cable. Reach under instrument panel and press and release button on switch and pull knob with shaft from switch. **NOTE** — On Maverick and Comet with air conditioning, gain access to release button by disconnecting left duct from register connector, loosening two nuts retaining register to shelf, and removing connector from register. Remove bezel nut from switch. Detach switch from panel. Lower switch and disconnect wiring. Remove switch. To install, reverse removal procedure.

All Models With Autolamp Headlight System — Refer to *Automatic Headlights, Ford Motor Co. Autolamp*, in this section, for headlight switch and potentiometer service.

STOP LIGHT SWITCH

All Models — Remove switch by disconnecting the electrical lead and then removing the master cylinder pushrod retainer and washer from brake pedal. Slide switch and pushrod off pin far enough to remove switch. To install, reverse removal procedure.

INSTRUMENT CLUSTER

Ford & Mercury — Disconnect battery ground cable. Remove lower steering column cover and instrument cluster trim cover. Disconnect cluster electrical connector from back of cluster. Disconnect speedometer cable and unhook and remove steering column shroud cover. Unhook shift quadrant cable from tab in shroud retainer and remove screw attaching cable to steering column. Remove four cluster attaching screws and remove cluster. To install, reverse removal procedure.

FORD MOTOR CO. (Cont.)

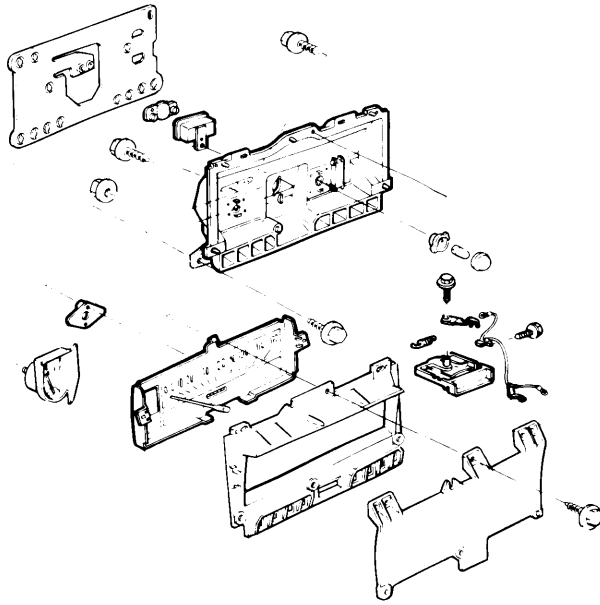

Fig. 2 Exploded View of Ford and Mercury Instrument Panel
Granada, Monarch and Versailles Assemblies are Similar

Monarch, Granada & Versailles – Disconnect battery ground cable. Remove lower cluster cover and shroud from steering column. From under instrument panel, press button on headlight switch and withdraw switch knob and shaft. Remove threaded headlight switch bezel, windshield wiper switch knob, and screws retaining cluster front cover. Pry cover away at top and pull rearward at bottom to unsnap cover-to-panel retainers. If equipped with automatic transmission, remove screw retaining shift quadrant cable to steering column. Disconnect speedometer cable, remove cluster to instrument panel retaining screws and pull cluster away from panel. Disconnect cluster connector from printed circuit, and if equipped with low fuel warning light, disconnect wires from fuel gauge studs. Remove cluster from instrument panel. To install, reverse removal procedure.

Thunderbird, LTD II & Cougar – Disconnect battery ground cable. Remove cluster trim cover and cluster-to-instrument panel retaining screws. Pull cluster away from panel and disconnect speedometer cable connector, cluster-to-printed circuit connector, and fuel economy light socket from the receptacle (if equipped). Disconnect overlay harness connector (if equipped with performance cluster), then remove instrument cluster. To install, reverse removal procedure.

Pinto & Bobcat – Remove two screws retaining upper and lower half of steering column shroud and remove lower half of shroud. Loosen forward steering column attaching nuts. Loosen rearward column attaching nuts about $\frac{1}{2}$ ". Disconnect printed circuit and tachometer connectors. Remove speedometer cable. Remove four screws retaining cluster and pull cluster out along angle of steering column. If equipped with optional gauge cluster, remove two screws retaining optional cluster to instrument panel. Remove housing from the front. Disconnect printed circuit plug. Remove cluster from rear through main cluster opening. To install, reverse removal procedure.

Lincoln Continental – Disconnect battery ground cable. Unsnap steering column trim shroud and remove instrument panel lower pad assembly. From under instrument panel, disconnect lower instrument cluster connector from printed circuit. Remove screw retaining shift quadrant cable to steering column and disconnect steering loop. Remove seven screws retaining gauge mounting plate to cluster housing and remove lower instrument cluster assembly. To install, reverse removal procedure.

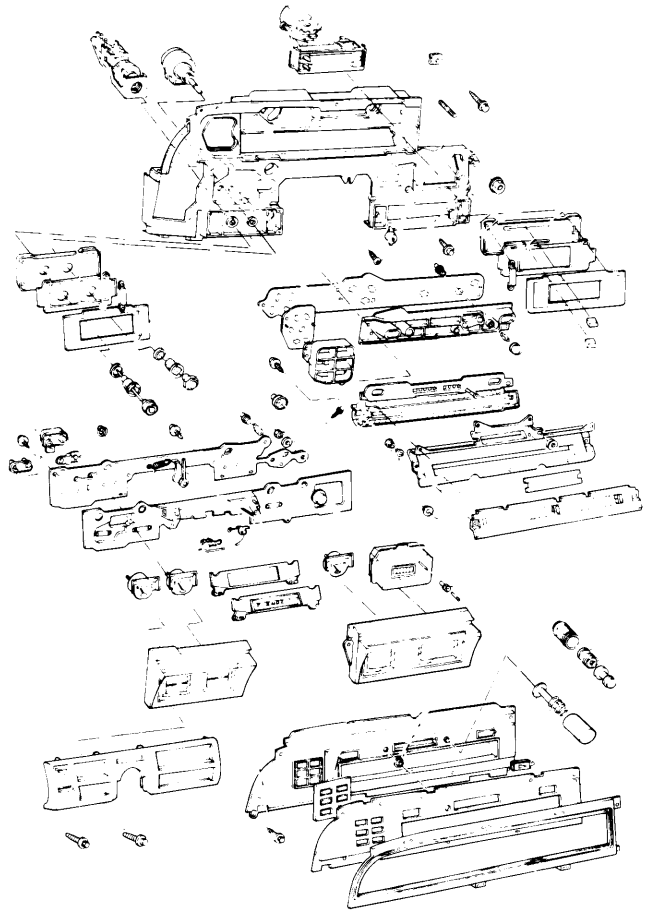

Fig. 5 Exploded View of Lincoln Continental Instrument Panel

Continental Mark V – Disconnect battery negative cable. Remove screws attaching upper access cover to instrument panel. Remove lower cluster applique cover and shroud from steering column. Remove heated rear window control knob. From under instrument panel press button on headlight switch and withdraw light switch knob and shaft. Remove headlight switch bezel, speedometer cable, windshield wiper control knob, wiper control bezel, cigar lighter and cluster front cover retaining screws. Pry cover away at top and pull rearward to unsnap cover-to-panel retainers. Remove shift quadrant cable to steering column retaining screw. Remove screws from top of cluster and remove light baffle. Remove screws retaining cluster to instrument panel, pull cluster away and disconnect cluster connector from printed circuit. Tilt cluster out, bottom first, and move cluster towards center of vehicle to remove. To install, reverse removal procedure.

FORD MOTOR CO. (Cont.)

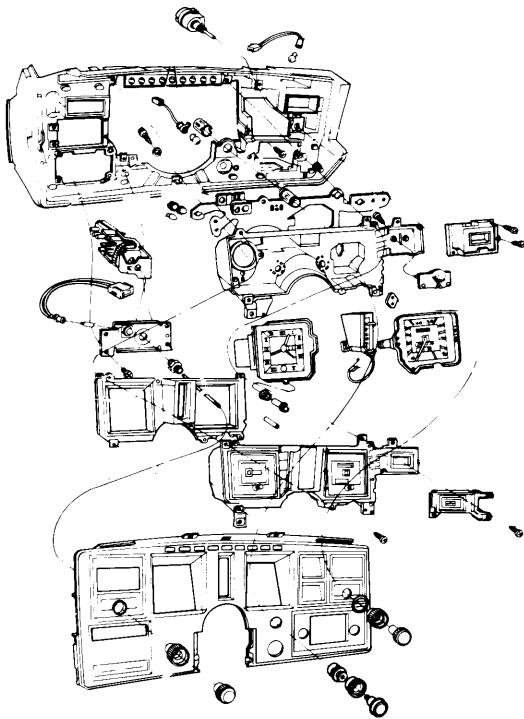

Fig. 4 Exploded View of Continental Mark V Instrument Panel

Maverick & Comet — Disconnect battery ground cable. From under instrument panel, press on flat of speedometer cable connector and pull cable away from head. Remove two top cluster retaining screws and swing cluster down. Disconnect electrical connector at printed circuit and remove cluster by disengaging it from the lower brackets. To install, reverse removal procedure.

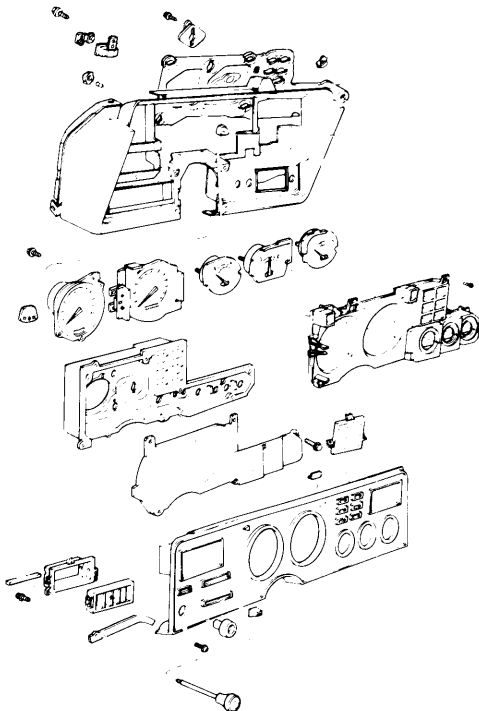

Fig. 3 Exploded View of Mustang Instrument Panel
Maverick, Comet, Pinto, Bobcat, Thunderbird, LTD II and Cougar Assemblies are Similar

Mustang — Disconnect battery ground cable. Remove windshield wiper switch knob, light switch knob and bezel. Remove cluster trim cover and from under instrument panel disconnect speedometer cable by pressing on flat surface of cable disconnect. Remove four screws retaining cluster to instrument panel and pull cluster out from panel. Disconnect printed circuit connector from cluster backplate, tachometer from it's connector and then remove cluster. To install, reverse removal procedure.

GAUGES & SPEEDOMETER

Lincoln Continental Speedometer — Remove instrument panel lower pad assembly. From upper pad assembly, remove left end finish panel, left access hole cover and map light assembly. Remove cluster trim cover by removing eight screws retaining it to cluster housing. Disconnect speedometer cable and remove speedometer retaining screws. To install, reverse removal procedure.

Lincoln Continental Gauges — With instrument cluster removed, removing housing and lens from cluster. Remove appropriate gauge retaining nuts from rear of cluster, then remove gauge. To install, reverse removal procedure.

Pinto, Bobcat, Maverick & Comet — Remove instrument cluster. Separate cluster front housing from backing plate by removing four retaining screws on rear of cluster. Remove speedometer or appropriate gauge by removing retaining screws. To install, reverse removal procedure.

All Other Models — With instrument cluster removed, separate cluster mask and/or lens by removing retaining screws and clock knob (if required). Remove speedometer or appropriate gauge retaining screws (or nuts on rear of cluster) and any remaining electrical or cable connections to that particular instrument. To install, reverse removal procedure.

INSTRUMENT VOLTAGE REGULATOR

Ford & Mercury — Disconnect battery ground cable. Remove lower access trim panel and from behind cluster remove printed circuit from IVR and radio noise suppressor. Remove IVR attaching screw, IVR and suppressor from cluster and suppressor from IVR. To install, reverse removal procedure.

All Other Models — With instrument cluster removed, remove IVR-to-cluster retaining screw and snap IVR off printed circuit connector buttons. Separate IVR from radio noise suppressor (if required). To install, reverse removal procedure.

PRINTED CIRCUITS

Lincoln Continental Upper Printed Circuit — Remove speedometer, then from under instrument panel remove upper cluster electrical connector, warning light baffle and six light sockets from warning light mounting plate. Remove printed circuit mounting plate, six sockets and then printed circuit. To install, reverse removal procedure.

Lincoln Continental Lower Printed Circuit — Remove lower instrument cluster and IVR. Remove printed circuit-to-clock retaining nuts and the light socket. Remove six gauge retaining nuts and three light sockets. Remove printed circuit from cluster. To install, reverse removal procedure.

All Other Models — Remove instrument cluster. **NOTE** — On 302" Mustang, remove tachometer module. Remove IVR, illumination and indicator bulbs and sockets, any gauge retaining nuts which are secured through the printed circuit, any electrical leads which may interfere, then remove printed circuit from cluster. To install, reverse removal procedure.