

CADILLAC

Cadillac, All Models

DESCRIPTION & OPERATION

Indicator Lights — Warning lights come on with the ignition in the "ON" and/or "CRANK" position, and go off when the engine has started. The "Coolant Temperature" indicator will come on and remain on when the coolant temperature is excessive. The "Stop Engine Temperature" indicator will be activated when the engine metal temperature is above 320°F and will be continuous until the temperature is below 240°F. All engines are effected if ignition is off or door is open.

TESTING

FUEL GAUGE

Use a suitable Gas Gauge Tester (J-22344 or equivalent). Disconnect Tan wire from the gas gauge tank terminal and connect one test lead to the wire and ground the other lead. Switch tester to "Empty" and "Full" positions and fuel gauge should read the same as the tester. If not, proceed with the following tests with ignition in "On" position.

Gauge Never Reads Empty or Reads Full At All Times — Check for disconnected or loose tank unit feed wire at tank. If good, check for proper connections at the printed circuit.

Gauge Always Reads Empty — Disconnect tank unit feed wire and gauge should indicate full. If not at "Full" position, check connections to printed circuit or for an open in the printed circuit.

Gauge Never Reads Full — Check system with Gas Gauge Tester, positioned in line between Tan wire and tank terminal. If gauge reads full, fill the gas tank. Using an ohmmeter, check resistance of tank sending unit which should read between 88 and 92 ohms. If ohm reading is low, check tank mounting area for damage. If gauge does not read full, check connections to printed circuit or for an open within the printed circuit.

Gauge Dead — Check feed wire voltage to the tank which should read 3-4 volts. If it does not, check for open on hot side of the gauge, or proper connections at the printed circuit. If voltage is correct, remove and check fuel gauge.

OIL PRESSURE INDICATOR

Indicator light is inoperative with ignition switch on and engine not running. Check for burned out bulb, open light circuit or defective oil pressure switch. Indicator light is on and engine is running, indicates low oil pressure, defective oil pressure switch or short between light and switch.

COOLANT TEMPERATURE INDICATOR

Lamp Off During Cranking — Check fuse. If fuse is good, turn ignition on and disconnect Green wire to sending unit at connector (in front of intake manifold on Seville; near A/C compressor on all others). Ground wire from dash connector. If light comes on, replace sending unit. If light remains off, check for burned out bulb. If bulb is good, check printed circuit connector. If lamp and connector are good, remove steering column-to-bracket retaining screws, allow column to drop and ground Dark Green wire at ignition switch. If lamp lights, replace ignition switch. If lamp remains off, check continuity of Dark Green wire between printed circuit and sending unit connector. If continuity exists, replace printed circuit.

Lamp On With Ignition On — Disconnect Green wire to sending unit at connector (in front of intake manifold on Seville; near A/C compressor on all others). If lamp goes off, replace sending unit. If lamp remains on, lower steering column and disconnect ignition switch connector. If lamp goes out, replace ignition switch. If lamp remains on, perform continuity checks for ground as described under "Lamp Off During Cranking".

STOP ENGINE TEMPERATURE INDICATOR

Lamp Fails To Come On — Disconnect Light Green wire from sending unit located on left cylinder head. Ground wire, and if lamp comes on and buzzer sounds, replace sending unit. If lamp remains off, check for open horn circuit breaker. If circuit breaker is good, check for burned out indicator bulb. If bulb is good, check printed circuit connector. If necessary, remove connector and check continuity between connector terminal and sending unit. If continuity exists, check for voltage at Orange/Black wire terminal or printed circuit connector. If voltage is present, wire is open between printed circuit connector terminal and "DX" terminal and sending unit. If voltage is not indicated, Orange/Black wire is open between connector and fuse block.

Lamp Fails To Go Off — Disconnect Light Green wire from sending unit. If lamp goes out, replace sending unit. If lamp remains on, Light Green wire between sender and "DX" terminal of dash connector may be grounded, or wire (Black-Pink Seville; Purple-White All Others) between "DX" terminal and printed circuit connector terminal may be grounded.

ALTERNATOR (GENERATOR) INDICATOR

Check for normal operation of indicator as follows: 1 — With ignition and engine off, lamp should be off. 2 — With ignition on and engine off, lamp should be on. 3 — With ignition on and engine running, lamp should be off.

If indicator operates properly, check battery for an under or over charged condition. If indicator does not operate as described, proceed as follows:

Switch Off, Lamp On — Disconnect alternator leads at connector. If lamp remains on, check for short between these leads. If lamp goes out and battery is low, check alternator rectifier bridge.

CADILLAC (Cont.)

Switch On, Engine Stopped, Lamp Off — Check 15 ampere "Cruise-A/C" fuse, indicator bulb and socket. Check wire (Pink on Seville; Orange on all others) between ignition switch and fuse and between fuse and bulb. Check Brown wire between bulb and dash connector. An open alternator diode can also cause indicator not to light.

Switch On, Engine Running, Lamp On — Check fan belt, alternator No. 1 and No. 2 lead connections and alternator internal circuitry.

ADJUSTMENT

STOP LIGHT & CRUISE CONTROL SWITCHES

Push switch well into retaining clip. Pull brake pedal up to full stop position and this will adjust switch. Rotate each switch $\frac{1}{2}$ turn counterclockwise to ensure vacuum switch will not hold brake pedal on after adjustment.

REMOVAL & INSTALLATION

STEERING COLUMN LOWER COVER

Remove four screws securing lower cover to lower steering column cover reinforcement. Remove four screws securing lower cover to instrument panel horizontal support. Remove lower cover. To install cover, reverse removal procedure.

LOWER LEFT INSTRUMENT PANEL (SEVILLE)

Disconnect negative battery cable. Remove steering column lower cover as previously described, then remove instrument cluster bezel. Remove trim screw from left side of lower panel, two screws retaining lower left panel to top cover, and loosen screw retaining lower panel to brace. Pull panel outward and disconnect electrical and vacuum connections from climate control, cruise control, headlight switch, and illumination bulbs, sockets and ground wire(s). To install, reverse removal procedure.

HEADLIGHT SWITCH

Seville — Remove steering column lower cover and lower left instrument panel cover as previously described. Pull headlight switch knob out of switch while depressing button on bottom of switch. Remove four screws retaining switch to panel insert, and remove switch from panel. Remove sleeve which retains switch to case. To install, reverse removal procedure.

All Others — Disconnect battery ground cable. Remove steering column lower cover as previously described. Disconnect electrical connector and lower light from switch. Pull headlight switch knob out of switch while depressing button on top of switch. Remove escutcheon and washer. Remove switch case-to-panel retaining screw, lower switch, disconnect upper switch light, and remove switch. To install, reverse removal procedure.

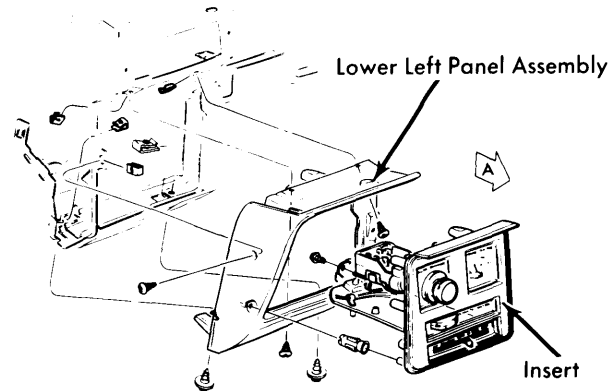

Fig. 1 Cadillac Headlight Switch (Seville)

INSTRUMENT PANEL PAD & AIR OUTLET GRILLES

Disconnect battery ground cable. Remove air outlet grilles using suitable remover-installer tool (J-21612) to compress release tabs; rotate grille upward to remove. Working through outlet openings, remove three fasteners securing pad to instrument panel support. Remove screws securing pad to instrument panel horizontal support.

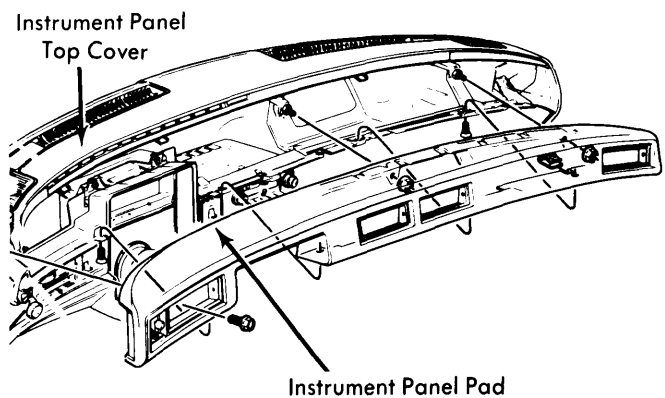

Fig. 2 Cadillac Instrument Panel (Exc. Seville)

INSTRUMENT PANEL TOP COVER

Seville — **NOTE** — Place shift lever in "LO" and tilt steering wheel to lowest position. Remove negative battery cable. Remove four screws on sides of defroster outlets, and five screws from lower edge of top cover. Pull top cover out and disconnect as required, the following connections: wiper switch, indicator light printed circuit, twilight sentinel photocell, clock, radio speaker, climate control sensor and aspirator, and security system indicator bulb and socket. Remove top cover. To install, reverse removal procedure.

CADILLAC (Cont.)

All Others — Remove instrument panel pad as previously described. Remove screw retaining top cover to left and right side of panel, and two top cover to horizontal support studs. Loosen nut retaining top cover to panel brace on cowl, located just forward and to the left of clock. Disconnect speaker lead at radio, pull top cover out, and disconnect as required, the following connections: printed circuit, fuel gauge and bulb, clock and bulb, climate control sensor hose, and twilight sentinel photocell. Remove top cover. To install, reverse removal procedure.

INDICATOR LIGHTS, PRINTED CIRCUIT & FUEL GAUGE

Remove instrument panel top cover as previously described. Remove indicator bulbs and sockets from printed circuit. Remove printed circuit retaining screws, then remove printed circuit. Remove fuel gauge, then remove housing to top cover retaining screws. Remove housing, housing cover, and lenses. To install, reverse removal procedure.

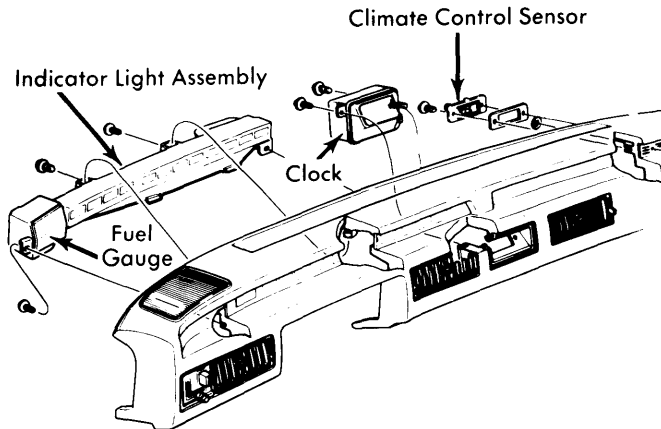

Fig. 3 Cadillac Indicator Light & Fuel Gauge Assembly (Seville)

SPEEDOMETER CLUSTER & BEZEL

All Models — **NOTE** — On Seville, bezel is one piece; on all other models bezel is in two pieces. To remove bezel, remove screws retaining bezel to cluster. On Seville, press bezel downward, and rotate top outward to remove. On all other models, remove bezel and steering column seal from steering column. To remove cluster, place shift lever in "P" and remove screw and washer retaining shift indicator cable to steering column. Remove two upper screws retaining cluster to panel support. Remove two lower inboard screws retaining cluster to speedometer cable retaining adaptor. **NOTE** — Do not remove cable retaining adaptor. Pull cluster outward to disengage speedometer cable, rotate top downward, disconnect printed circuit connector, then remove cluster. To install, reverse removal procedure.

SPEEDOMETER CLUSTER PRINTED CIRCUIT

Remove cluster and all sockets and lights from cluster case, then remove printed circuit. **NOTE** — Do not repair printed circuit board, if defective, it should be replaced. To install circuit board, reverse removal procedures.

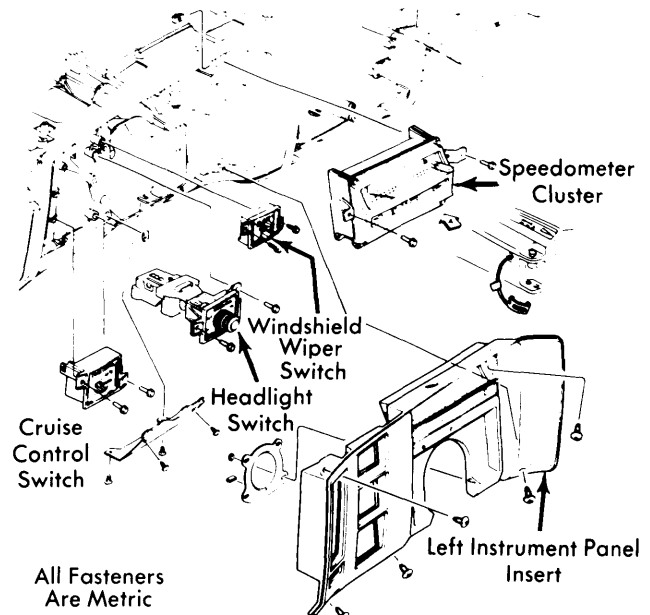

Fig. 4 Cadillac Speedometer Cluster (Exc. Eldorado and Seville)

SPEEDOMETER HEAD

To remove speedometer head, remove instrument cluster as previously outlined. Then remove four screws securing instrument cluster lens to cluster housing. Remove trip reset knob by turning counterclockwise. Hold shaft on flats under knob. Remove lens and face plate. Remove selector quadrant assembly from cluster housing by pulling straight out. Remove rubber mounted screws securing speedometer head assembly and remove from cluster housing. Remove screws securing dial to speedometer head and remove dial using care not to damage pointer. To install speedometer head, reverse removal procedures.

LOWER RIGHT INSTRUMENT PANEL & ACCESSORY SWITCHES

Remove radio knobs, springs, rings, and retaining nuts. Remove insert retaining screws through opening in top of glove box. Push accessory switch(es) until it pops out of insert. Disconnect bulbs and map light connector. To install, reverse removal procedure.

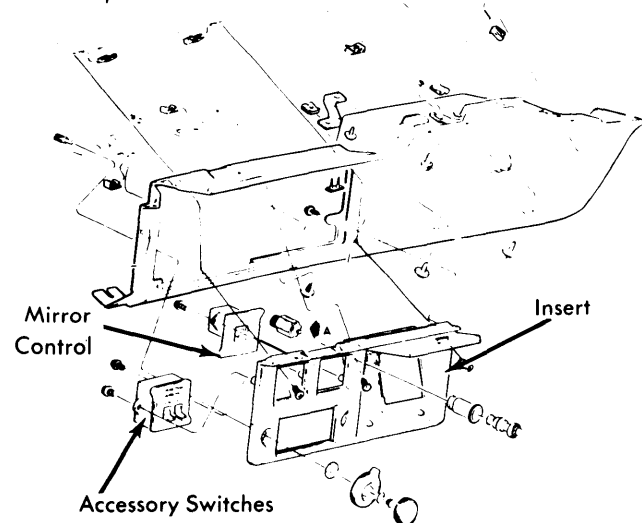

Fig. 5 Cadillac Lower Right Instrument Panel (Seville)