

GENERAL MOTORS ELECTRONIC CRUISE CONTROL - CADILLAC

Cadillac
All Models

DESCRIPTION

The Electronic Cruise Control System uses electrical sensors and components, to regulate the vacuum operated servo, which in turn controls the carburetor throttle linkage. The system includes the following: an instrument panel control switch; an engagement switch in end of turn signal lever; a speed sensor on the speedometer; two brake release switches (one vacuum and one electrical) on brake pedal bracket; an electronic control module on back of instrument panel; a relay under the instrument panel; a vacuum servo (power unit) near carburetor; a vacuum control valve on servo; a solenoid valve on servo; a throttle control bead chain (Eldorado and Seville), or a throttle control cable (all other models); and, various vacuum hoses and electrical wiring harnesses.

OPERATION

The system uses manifold vacuum to actuate the servo. The amount of vacuum to the servo is controlled by the solenoid valve attached to the servo inline with the vacuum control valve. The solenoid valve constantly modulates vacuum to the servo in response to commands from the electronic control module. The control module receives signals from the engagement and instrument panel switches, electrical brake release switch, and speed sensor. The speed sensor, near the speedometer cable, consists of a light emitting diode and a photo transistor. Power to the diode is supplied when the system is turned on. When the photo transistor is exposed to

light from the diode, the transistor generates a signal to the control module. These signals are representative of the cars speed. Input signals received from the sensor by the control module are used to control the solenoid valve which regulates the amount of vacuum supplied to servo. When the brakes are applied, the electrical brake release switch cancels the control module signal to the solenoid valve, thus shutting off the system and venting the vacuum servo. The vacuum brake switch also vents the system vacuum as a second disengagement system.

The control switches operate as follows: With instrument panel switch set to "CRUISE" and engagement switch fully released, the system is not engaged. Or, if system was previously engaged, the throttle position for the previously desired speed will be maintained. With the engagement switch in the center (detent) position, the solenoid valve regulates the vacuum supplied to the servo to initially set or reset the speed. With the engagement switch fully depressed, the servo is vented to atmosphere. This position is used by the driver when a decrease in speed is desired. If the driver fully depresses the button with no pressure on the accelerator pedal, then releases the button, the car will cruise at the new lower speed. With the instrument panel switch in the "AUTO" position, operation is the same except when the engagement switch is in the center (detent) position. In this position, the driver can engage the system at a given speed. If braking was necessary, partially depressing button will automatically accelerate car, at a controlled rate, until previously set speed is attained. Or, partially depressing the button and holding it will allow an automatically controlled rate of acceleration until the button is released. The car will now cruise at the new speed.

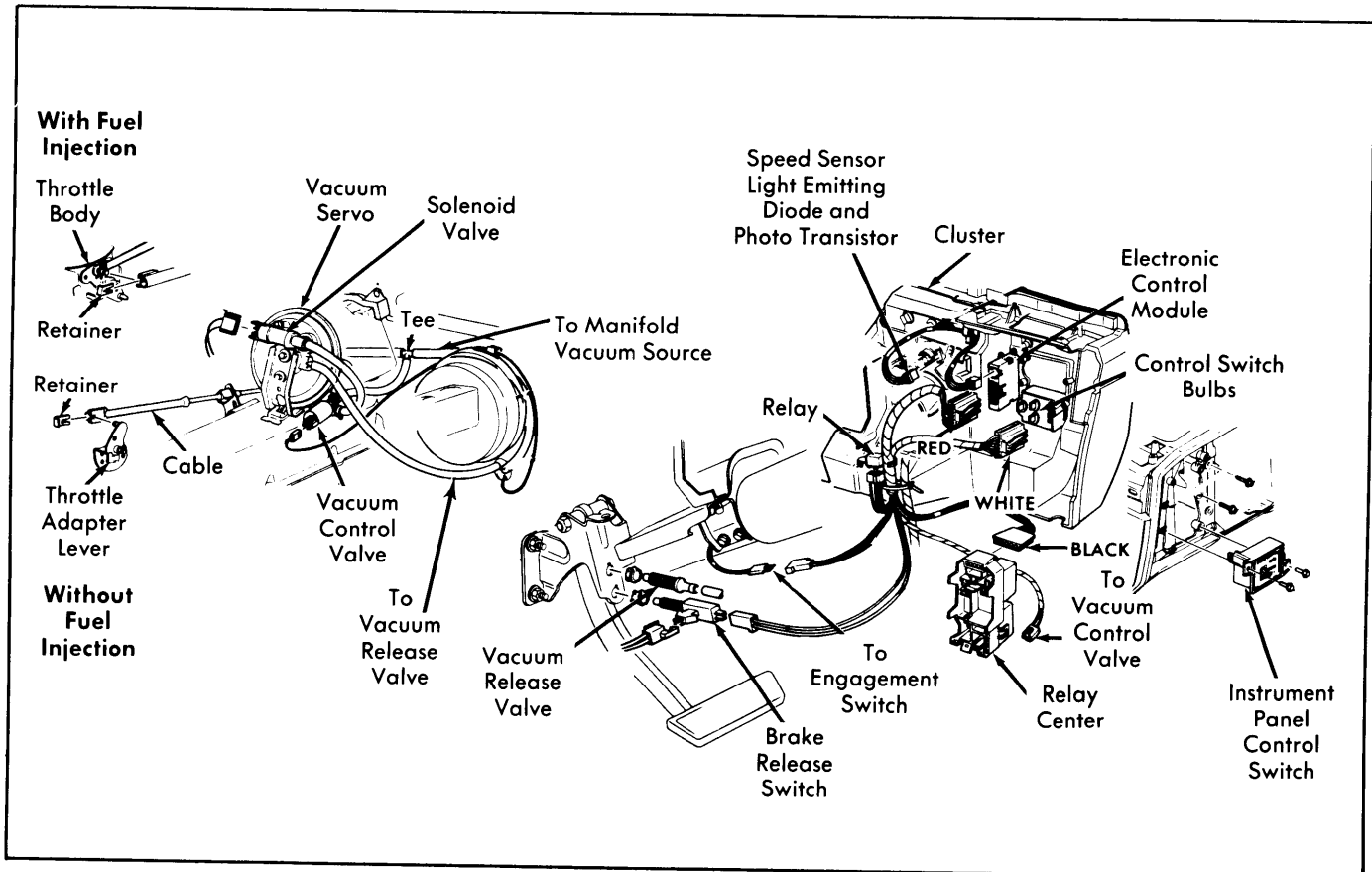

Fig. 1 Typical Electronic Cruise Control Component Location and Identification (Cadillac Shown, Seville and Eldorado Similar)

Speed Control Systems – Automatic 5-63

GENERAL MOTORS ELECTRONIC CRUISE CONTROL - CADILLAC (Cont.)

TROUBLE SHOOTING & DIAGNOSIS

CONDITION	CAUSE	CORRECTION
Servo diaphragm extends to maximum allowable open throttle position A. Position of dash switch has no effect. Vehicle returns to idle with brake application, may duplicate when pedal is released B. Condition occurs only when dash switch is in cruise or auto position. Condition will cancel when panel switch is turned off.	Servo solenoid valve leaking vacuum	Replace valve
	Manifold vacuum connected directly to power unit vacuum vent port.	Reroute vacuum hose
	Unrequested voltage on solenoid feed.	Defective control module. Replace
Erratic engagement and/or unwanted program acceleration.	Severed engage switch harness in column.	Replace harness.
	Open circuit in yellow wire connector.	Repair wire connector.
Will not cruise at engaged speed.	Leak in servo diaphragm	Replace servo and inspect vacuum system
	Leak in vacuum release valve or hose.	Replace or repair hose or valve.
	Throttle actuating cable or bead chain slack, excessive or sticky.	Free throttle linkage and remove slack from cable or chain.
	Kinked or damaged speedometer cable	Replace speedometer cable.
	Servo solenoid valve variable orifice mis-	Readjust. adjusted.
System will not disengage with brake pedal	Brake release switch inoperative or mis-adjusted.	Replace or adjust brake switch as required.
Cannot engage or adjust cruise speed downward with engage switch.	Inoperative engage switch.	Replace or repair engage switch
System can be engaged below 20 MPH	Defective control module.	Replace module.
Hissing noise when brake pedal disengages system	Vacuum release valve or release switch	Readjust or replace valves misadjusted
Amber ON" light will not turn on even though system cruises satisfactorily.	Inoperative bulb.	Replace bulb.
	Open printed circuit on dash switch.	Replace printed circuit and/or switch.
"CRUISE" or "AUTO" light will not turn on even though system cruises satisfactorily	Inoperative bulb.	Replace bulb.
	Open printed circuit on dash switch.	Replace printed circuit and/or switch
	Defective control module.	Replace control module.
Cruise speed drops when heavy electrical loads are turned on such as headlights, air conditioning, etc.	Battery voltage in vehicle too low	Correct battery problem.

GENERAL MOTORS ELECTRONIC CRUISE CONTROL - CADILLAC (Cont.)

TESTING

ROAD TEST

- 1) Place instrument panel control switch in "OFF" position. Drive car at 50 MPH. Push engagement switch button to center (detent) position and release. Vehicle speed should decrease.
- 2) Place dash switch at "CRUISE" position. Amber indicator light should come on. Push engagement switch button to center (detent) position and release when vehicle speed is 50 MPH. Green light should come on (on dash switch) and vehicle should maintain 50 MPH with foot off accelerator. Note the amount of cruising speed, if any, above or below the 50 MPH "lock-in" speed. **NOTE** — The "Lock-In" speed can be adjusted as outlined in this story.
- 3) Place dash switch in "AUTO" position; vehicle speed should not change. Hold engagement switch button in center position, leaving foot off accelerator. Vehicle speed should slowly accelerate. Release button at 55 MPH and vehicle speed should be maintained at the new 55 MPH setting.
- 4) Depress brake pedal about 1/2". Green light should go off. If so, electric brake switch is okay. Vehicle speed should decrease. Allow vehicle to slow to about 45 MPH.
- 5) Depress engagement button to detent position, vehicle should automatically accelerate to 55 MPH and green light should come on.
- 6) Push and hold button all the way in. Green light should go off and vehicle should slow down. Release button to engage system at 50 MPH. Green light should come on and vehicle should maintain the 50 MPH speed.

ELECTRIC BRAKE RELEASE SWITCH

- On Vehicle Test** — 1) Turn ignition on and instrument panel switch to either "CRUISE" or "AUTO". Connect test light or voltmeter to ground.
- 2) Probe Blue wires at connector. Lamp should light or meter should read 12 volts indicating feed from dash switch.
 - 3) Probe Pink/Black wire at connector. Lamp should light or meter should read 12 volts indicating switch continuity.
 - 4) Check switch adjustment with probe at Pink/Black lead while depressing brake pedal 1/8" to 1/2". Light should turn off or meter should drop to zero. If not, adjust or replace switch as required.

INSTRUMENT PANEL SWITCH & HARNESS

- On Vehicle Test** — 1) With engine off and ignition on, connect test light to ground. Disconnect the three wires from the engage switch from the cruise harness connector.
- 2) Test each cruise harness connector terminal with instrument panel switch in "OFF", then "CRUISE", and finally in "AUTO" position. In "CRUISE" and "AUTO" switch positions, amber indicator light should come on, and the checks should indicate the following:

On Car Instrument Panel Switch Test Indications

Indication at Terminal No. (Wire Color)

Switch Position	1 (Yellow)	2 (Green)	3 (Red)
Auto	Off	On	Off
Cruise	On	Off	Off
Off	Off	Off	Off

Bench Test — Use ohmmeter or self powered test light. The printed circuit terminals are lettered "A" through "H" on harness connector and on switch from top "A", to bottom "H". The checks should indicate the following:

Instrument Panel Switch Bench Test Indications

Indications Between Terminals

Switch Position	A to B	A to C	E to F
Auto	Closed	Open	Closed
Cruise	Open	Closed	Closed
Off	Open	Open	Open

ENGAGEMENT SWITCH & HARNESS

On or Off Vehicle Tests — Disconnect switch from harness and make the following checks using an ohmmeter. If indications are bad, replace switch.

On or Off Car Engagement Switch Tests

Indications Between Terminal No. (Wire Color)

Switch Position	1 to 2 (Yel. to Grn.)	1 to 3 (Yel. to Red)	2 to 3 (Grn. to Red)
Released	Closed	Closed	Closed
Partially Depressed	Open	Open	Closed
Fully Depressed	Closed	Open	Open

NOTE — Connect ohmmeter to steering column bracket, then check each terminal. All should show open circuits. If continuity is indicated, a short exists. Replace lever and harness.

VACUUM CONTROL AND SERVO SOLENOID VALVES

Resistance Test (Engine Off) — 1) Disconnect harness at valve to be tested. Connect ohmmeter to terminals on valve.

2) Resistance should be between 55 and 70 ohms on servo solenoid valve, or between 23.5 and 27.5 ohms on vacuum control valve. Replace valve if resistance is not within specification.

Functional Test (Engine Running) — 1) Before starting engine, disconnect bead chain or cable from servo and disconnect harness connectors at both valves. Start engine and run at idle speed.

Speed Control Systems — Automatic 5-65

GENERAL MOTORS ELECTRONIC CRUISE CONTROL - CADILLAC (Cont.)

2) Ground one terminal of vacuum control valve. Connect a jumper wire to battery positive post. Touch battery jumper to ungrounded terminal. Servo diaphragm should not move. If it does, servo solenoid valve is leaking and must be replaced.

3) Remove jumper wires from control valve and test servo solenoid valve in same way as above. If servo diaphragm moves, control valve is leaking and must be replaced.

2) With engine idling, voltage should be less than 1.0 volts D.C. Increase idle speed for several seconds. Reading should still be less than 1.0 volts D.C. Any indication above 1.0 volts D.C. means control unit should be replaced.

CONTROL MODULE CURRENT LEAK

Test At Servo Solenoid Valve Connector (Engine Running) — 1) Disconnect harness at solenoid valve and using a D.C. voltmeter check voltage between connector terminals.

CONTROL MODULE

Do not attempt to repair control module. Insure connectors are tight and fully seated. If all other components of system test out okay, replace control module.

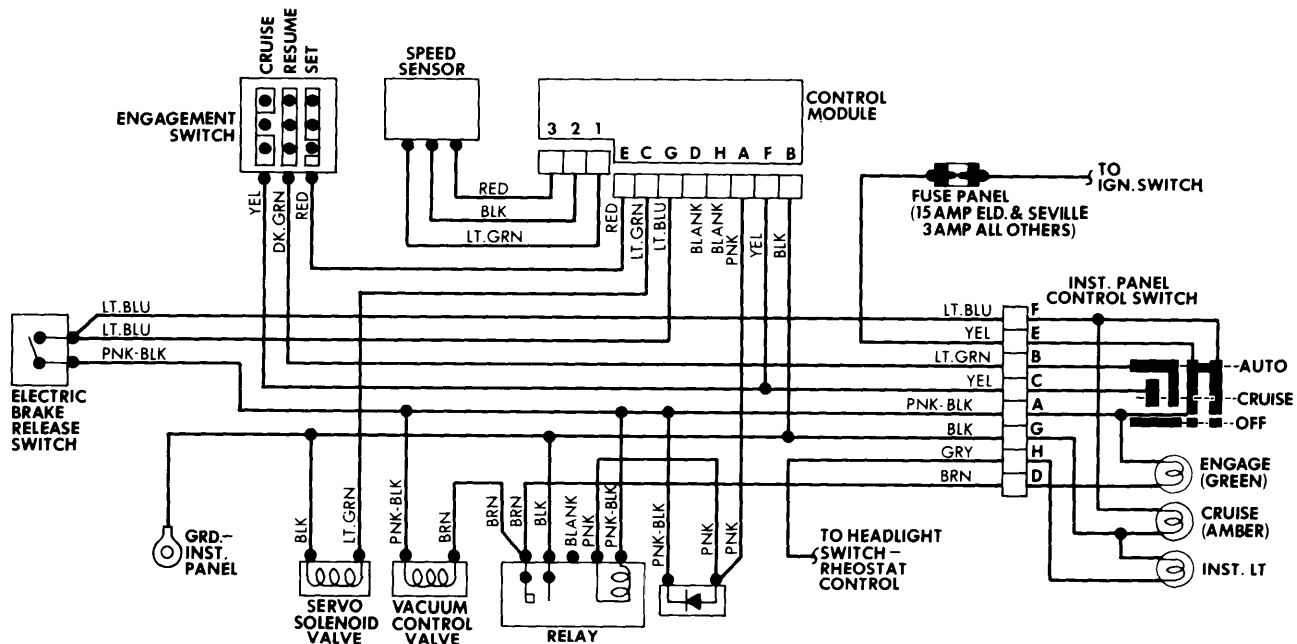

Fig. 2 Wiring Diagram of General Motors (Cadillac) Electronic Cruise Control System

INSTRUMENT PANEL SWITCH INDICATOR LIGHTS

Amber "ON" Light — 1) Turn ignition on and place dash switch in "CRUISE" position and then in "AUTO" position. Amber light should come on in both switch positions.

2) If amber light did not come on in both positions, check for burned out bulb, open circuit in ground wire or connector, or for an inoperative switch or printed circuit.

3) Place dash switch in "OFF" position. If amber light comes on, check for shorted leads, inoperative switch or blown fuse.

Green "CRUISE" Light — 1) If system properly controls the cars speed but the green indicator light does not work correctly, check for burned out bulb or an open circuit in Pink wire between switch connector and control module connector.

2) If green indicator light remains on when system is not controlling the cars speed, check for the following: a short circuit in harness between switch and relay, a malfunctioning relay, or, a short in Pink wire between relay and control module connector. If the above checks are okay, replace control module.

SPEED SENSOR TESTS

On vehicle With Engine Off — 1) Partially remove speedometer cluster so access to speed sensor is possible. For cluster removal, see appropriate story in SWITCHES, GAUGES & SPEEDOMETERS in this section.

2) Turn ignition on and cruise control dash switch to either "CRUISE" or "AUTO". Connect voltmeter between ground and terminal 2 (Black) on speedsensor 3-wire connector. Note and record voltage reading. Reading should be greater than 10 volts but less than battery voltage.

3) Connect voltmeter between ground and terminal 3 (Red) on sensor connector. Voltage should be one to two volts less than at terminal 2. This is the voltage drop through the light emitting diode.

4) Connect voltmeter between ground and terminal 1 (Green) of sensor connector. Roll car forward (approximately six feet) while checking voltage. Two voltage peaks should occur in the distance the car travels. This is the photo transistor output.

GENERAL MOTORS ELECTRONIC CRUISE CONTROL - CADILLAC (Cont.)

**VACUUM SYSTEM INSPECTION
(VACUUM CIRCUIT FUNCTIONAL TEST)**

- 1) Before starting engine, disconnect bead chain or cable from servo. Disconnect electrical leads at vacuum control and solenoid valves.
- 2) Actuate vacuum control and solenoid valves by connecting jumper wires to one terminal of each valve to ground, and a jumper wire from the other terminals to battery.
- 3) Start and run engine at idle. With brake pedal released, servo diaphragm should pull in to full stroke. Depress brake pedal about 1½" and servo diaphragm should relax to the free position, indicating that vacuum brake release valve and hose are okay.
- 4) If system will not hold vacuum, remove brake release valve vent hose from servo and plug servo vacuum fitting (manifold vacuum should be open).
- 5) If servo diaphragm draws in, problem is in brake release vacuum vent system. If servo will not draw in, inspect servo diaphragm and vacuum connectors at all vacuum valves.

VACUUM CONTROL VALVE ELECTRICAL CIRCUIT FUNCTIONAL TEST

- 1) Before starting engine, disconnect bead chain or cable at servo, and disconnect vacuum hose between control valve and solenoid valve at servo. Connect jumper wire between ground and cavity "A" on rear of large control module wiring connector. Start and run engine at idle.

2) Amber "ON" light on dash switch should be on. Perform tests on system as shown in Vacuum Control Valve Circuit Functional Tests chart.

3) If all conditions indicated in Vacuum Control Valve Circuit Functional Test chart are okay, but system still does not operate properly, test each component separately.

ADJUSTMENTS

ELECTRIC BRAKE RELEASE SWITCH AND VACUUM BRAKE RELEASE VALVE

Push switch or valve all the way in to the retaining clip. Pull brake pedal up to the stop to automatically adjust the switch or valve. Insure free play exists between pedal and switch bodies when pedal is pulled away from released position and before hitting brakes applied position.

ENGAGEMENT SWITCH

Switch can not be adjusted. Replace switch if found defective.

"LOCK-IN" ERROR CORRECTION

Locate screw on solenoid valve. Turn screw toward "S" to reduce the lock-in speed. Turn screw toward "F" to increase lock-in speed.

VACUUM CONTROL VALVE CIRCUIT FUNCTIONAL TESTS		
DASH SWITCH AT "CRUISE" OR "AUTO"		
Check Should Indicate	Possible Cause or Malfunction	Correction
Green engage light should turn on	Dash switch, harness, relay or bulb	Replace as required.
Control harness relay should energized.	Open in coil relay, or disconnect or open circuit in harness.	Replace or repair as required.
Vacuum control valve should open and there should be vacuum at disconnected hose.	Defective control valve.	Replace as required.
	Obstruction or leak in vacuum supply to valve.	Repair as required.
	Disconnect or open in harness to valve.	Repair as required.
REMOVE JUMPER WIRE		
Check Should Indicate	Possible Cause or Malfunction	Correction
Green engage light should turn out.	Shorted or stuck relay. Harness shorted to ground	Replace or repair.
Control valve should close, no vacuum at disconnected hose.	Control valve stuck or leaking	Replace valve