

FORD MOTOR CO.

Ford Motor Co.

DESCRIPTION

Speed control system consists of an "ON-OFF" switch and "SET-ACC" and "COAST" switch, servo assembly, sensor, amplifier, vacuum reservoir, wire harness, and vacuum hoses to connect components. The switches are located in steering wheel spokes, and the servo assembly is located in the engine compartment. The sensor is located in the engine compartment on Lincoln and Continental Mark V, and under the instrument panel on all other models.

OPERATION

This system is operational at speeds above 30 MPH. When the "ON - OFF" switch is set to the "ON" position and the driver depresses and releases the "SET - ACC" button, the vehicle speed will be maintained until a new speed is set by the driver, until the brake pedal is depressed, or until the system is turned off.

TESTING

CONTROL SWITCH

1) Disconnect six-way connector at amplifier assembly. Connect voltmeter between Lt. Blue-Black lead and ground.

Depress "ON" button and check for battery voltage with ignition switch on. Turn ignition off.

2) Connect ohmmeter between Lt. Blue-Black lead and ground. Rotate steering wheel and make the following tests:

Depress "OFF" button and check for a reading between zero and one ohm.

Depress "SET" button and check for a reading of 646 to 714 ohms.

Depress "COAST" button and check for a reading of 114 to 126 ohms.

If resistance values are okay but meter needle fluctuates, remove steering wheel and clean contact surfaces of speed control ground brush. If resistance readings are high, check switch assemblies and ground circuit in steering column.

SPEED SENSOR

Disconnect sensor wires from amplifier and connect an ohmmeter between wire connector terminals (green & black). A reading of about 40 ohms should be obtained. A reading of 0 ohms indicates a shorted coil and a maximum reading indicates an open coil. Replace sensor in either case. If reading is 40 ohms and speedometer operates properly, speed sensor is probably good. A new sensor should be substituted in place of old sensor to check for proper operation.

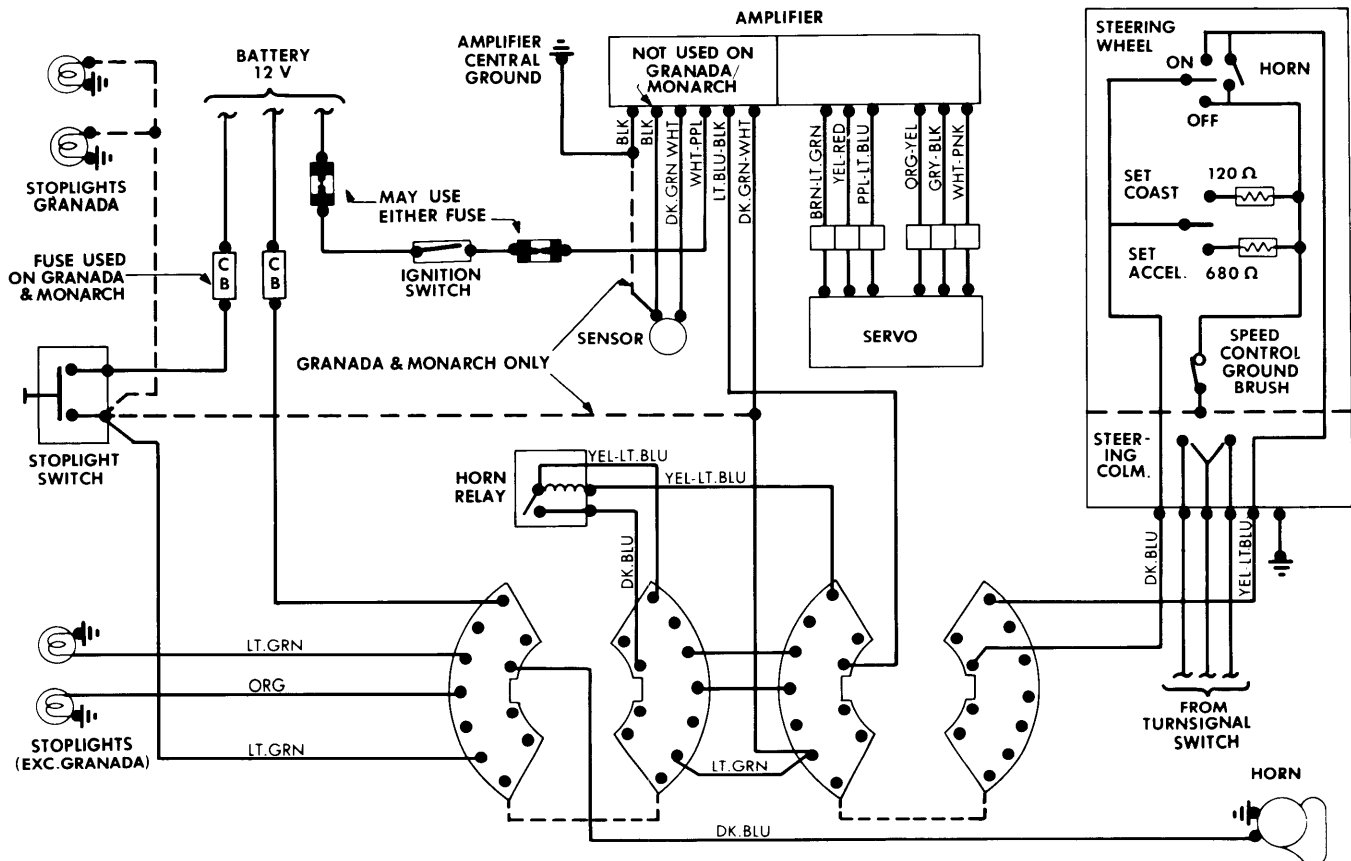

Fig. 1 Wiring Diagram of Ford Motor Co. Automatic Speed Control System.

FORD MOTOR CO. (Cont.)

SERVO ASSEMBLY

CAUTION — If Orange-Yellow lead is shorted to either White-Pink or Grey-Black leads it may be necessary to replace the amplifier.

- 1) Disconnect ball chain from throttle linkage. Separate servo-to-amplifier connector. Connect an ohmmeter between Orange-Yellow and Grey-Black wires at servo connector. Resistance should be approximately 85 ohms.
- 2) Connect ohmmeter between Orange-Yellow and White-Pink wire leads. Resistance should be approximately 85 ohms. Reconnect ball chain.
- 3) Start engine. Jumper Orange-Yellow lead of servo connector to battery positive post and White-Pink lead of servo connector to ground. Momentarily touch Grey-Black lead of servo connector to ground. Servo throttle actuator should tighten bead chain to open throttle. Throttle should hold in that position, or slowly release chain tension. If White-Pink wire is removed from ground, servo should immediately release tension on chain.

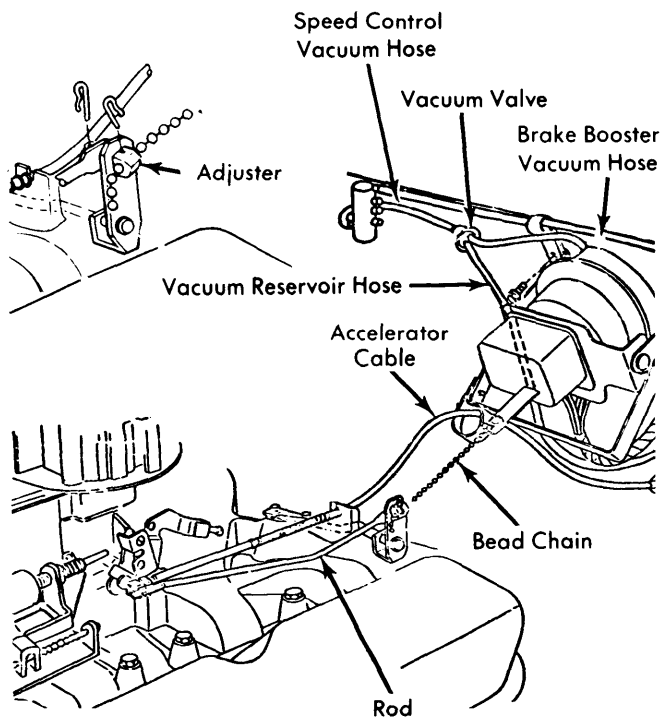

Fig. 2 Engine Compartment Speed Control Components for Ford and Mercury Models

AMPLIFIER

CAUTION — DO NOT use a test light to perform amplifier tests because too much current draw will damage electronic components. Use only a voltmeter of 5000 ohm/volt rating or higher.

Make the following tests at the amplifier six-way harness connector.

"ON" Circuit Test — 1) Turn ignition on and connect voltmeter to Lt. Blue-Black wire and ground. Depress and hold "ON" switch in steering wheel. Meter should read 12 volts. If voltage is not available, check horn relay circuit and perform Control Switch Test.

2) Release the "ON" switch; 12 volts should remain at the Lt. Blue-Black wire showing that the "ON" circuit is engaged. If voltage drops, check for ground at amplifier, fuse, and/or circuit breaker. Insert a known good amplifier and recheck "ON" circuit if necessary.

"OFF" Circuit Test — Turn ignition on and connect voltmeter to Lt. Blue-Black wire and ground. Depress "OFF" switch in steering wheel. Voltage should drop to zero when switch is depressed showing that the "ON" circuit has been turned off. If voltage does not drop, perform Control Switch Test. If "OFF" circuit test okay, install a known good amplifier and retest.

"SET-ACCELERATE" Circuit Test — Turn ignition on and connect voltmeter to Lt. Blue-Black wire and ground. Depress "ON" button on steering wheel then hold down on "SET-ACCEL" button. Voltmeter should read approximately 10 volts. Rotate steering wheel and watch voltmeter for variation. If voltage varies more than 0.5 volt, perform Control Switch Test.

"COAST" Circuit Test — Turn ignition on and connect voltmeter to Lt. Blue-Black wire and ground. Depress "ON" switch in steering wheel and hold down on "COAST" button. Voltmeter should read about 6 volts. If all functions check good, perform Servo Test and Sensor Tests, and install a known good amplifier and recheck.

CAUTION — Do not substitute a new amplifier until actuator coils have been tested as described in Servo Assembly Tests.

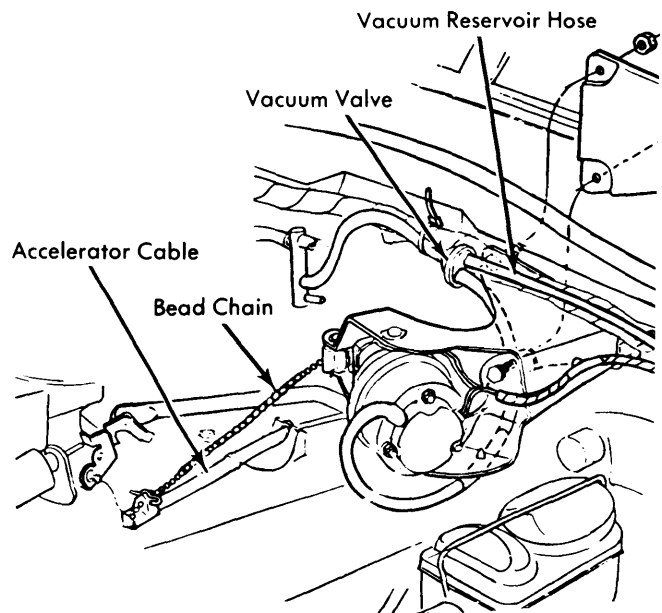

Fig. 3 Engine Compartment Speed Control Components for Thunderbird, LTD II, and Cougar with 351 and 400 Engines

FORD MOTOR CO. (Cont.)

ADJUSTMENTS

LINKAGE ADJUSTMENT

Adjust bead chain to obtain $\frac{1}{16}$ "- $\frac{1}{4}$ " actuator arm free travel when engine is at hot idle speed. On vehicles with idle stop solenoids, perform this adjustment with ignition switch in the "ON" position.

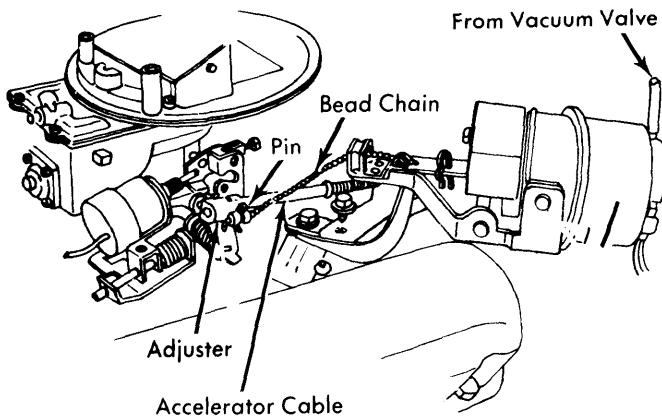

Fig. 4 Engine Compartment Speed Control Components for Granada and Monarch V8 (Thunderbird, LTD II, and Cougar with 302" Engine is Similar)

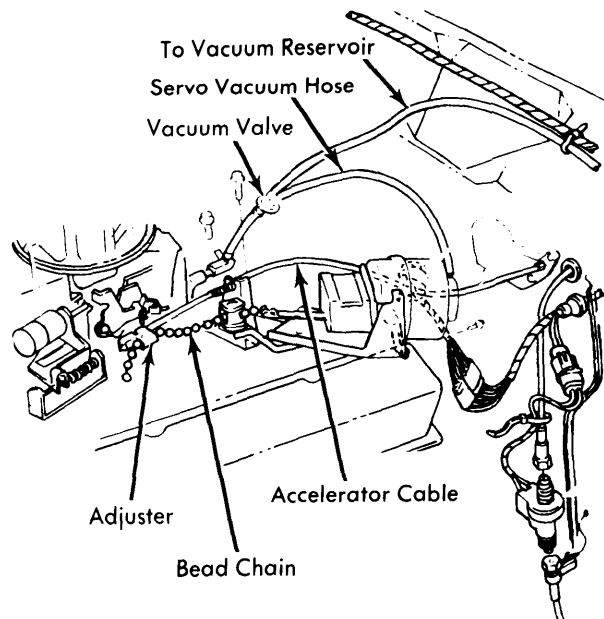

Fig. 5 Engine Compartment Speed Control Components for Continental Mark V (Lincoln Continental is Similar)

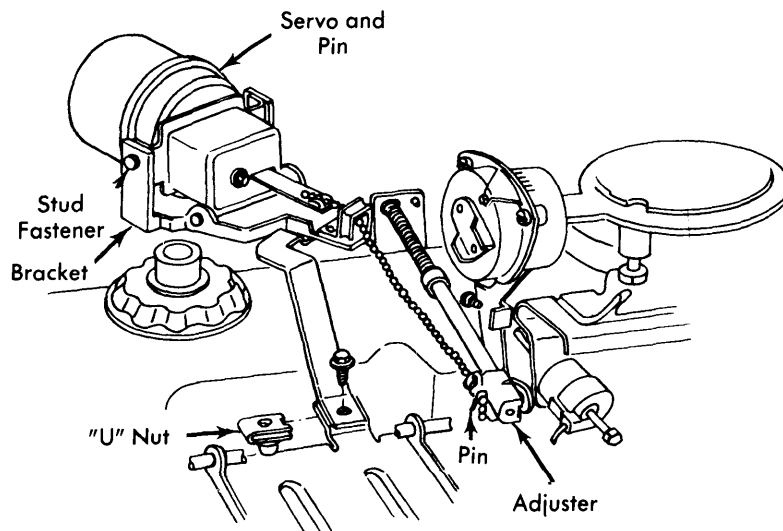

Fig. 6 Engine Compartment Speed Control Components for Granada and Monarch Six Cylinder Engine