

Seat Controls – Electric

FORD MOTOR CO. 4-WAY

Ford Granada
Mercury Monarch
Lincoln Versailles

DESCRIPTION & OPERATION

The 4-way power seat provides horizontal movement as well as vertical movement of the front edge of the drivers seat (bucket or flight bench type seat only). The seat is driven by a dual motor and uses two gear boxes and flexible drive cables. The control switch on the lower left side of drivers seat directs current to the motor.

TESTING

Separate connectors under seat, then test switch and wiring using test light or ohmmeter as follows:

Input Circuit Tests

Switch Position	Continuity Between Terminals
Neutral.....	No continuity between 51 and any terminal.
Up.....	51 and 978
Down.....	51 and 979
Forward.....	51 and 180
Rearward.....	51 and 179

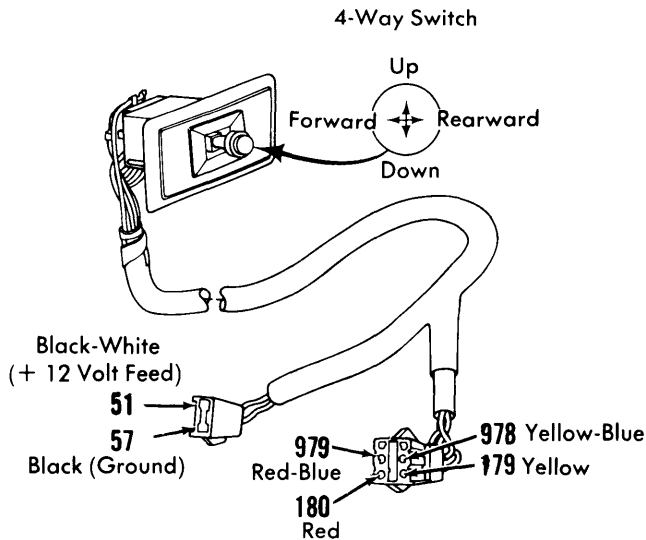

Fig. 1 4-Way Power Seat Connector Terminal Identification

Ground Circuit Tests

Switch Position	Continuity Between Terminals
Neutral.....	Continuity between 57 and all other terminals.
Up.....	57 and 179, 180, 979
Down.....	57 and 179, 180, 978
Forward.....	57 and 179, 978, 979
Rearward.....	57 and 180, 978, 979

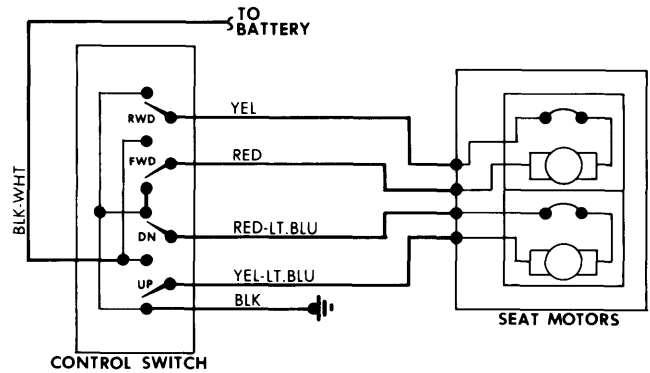

Fig. 2 Granada and Monarch 4-Way Power Seat Wiring Diagram (Versailles Similar)

REMOVAL & INSTALLATION

SEAT & TRACK

Removal – Electrically raise seat and position it as far rearward as possible. Remove seat track-to-floor attaching bolts. Disconnect feed and switch wiring connectors, then remove seat from vehicle.

Installation – Reverse removal procedure, then using the control switch, check seat operation in all positions.

MOTOR & DRIVE CABLES

Removal – With seat removed from vehicle, separate seat cushion from track by removing cushion retaining screws from each corner of track. Remove motor and bracket by removing bracket attaching screws from bottom side of track assembly. Separate motor from bracket by removing nuts securing motor to bracket. Remove cables and cable tube from drive assembly.

Installation – Reverse removal procedure, then using the control switch, check seat operation in all positions.