

CHRYSLER CORP.

Chrysler
Dodge

TESTING

DESCRIPTION

Headlamp doors are electrically operated by a single motor mounted behind the center grille. The motor is series wound with two field windings, and has a worm gear drive and internal limit switches. The relay and circuit breaker assembly is mounted on the lower reinforcement of instrument panel on passenger side.

OPERATION

When headlight switch is turned on, relay is energized completing motor circuit, and doors are rotated to the open position. When doors reach the open position, a limit switch cuts off power to motor. When headlight switch is turned off, relay completes door closing circuit, and doors are rotated to the closed position. When doors reach the closed position, a second limit switch cuts off power to motor.

EMERGENCY OPERATION

If headlight doors do not open when headlight switch is turned on, doors can be opened manually as follows: Raise hood and disconnect motor leads, then rotate the hand wheel (located at lower end of motor) clockwise until headlight doors are fully opened. **CAUTION** — Do not rotate wheel after doors reach end of travel as damage to motor will result.

MOTOR

1) Using jumper wires and car battery as source of power, apply current to motor terminals after limit switch and check motor operation in both directions. **CAUTION** — This test bypasses limit switches and power should be applied only momentarily to avoid system damage. If motor draws current but does not operate in either direction, motor has an internal short or a locked armature and must be replaced. If motor draws no current, an open circuit exists and motor must be replaced. If motor operates, apply power to terminals before limit switch. If motor now operates in both directions, limit switches are good. If motor fails to operate, check limit switches.

2) Use jumper wires at bulkhead-disconnect to check for voltage at terminal for both lights on and off. If no voltage present for either position, test for loose wire at "H" terminal of headlamp switch, loose wires on headlamp motor relay or faulty circuit breaker.

LIMIT SWITCHES

Remove torsion bar and motor. Remove switch plate and examine gear for damage. Ensure that switch blade contact surfaces are clean. Rotate gear assembly, while pressing it against switch plate, and observe operation of limit switches. **CAUTION** — Do not over rotate since cam can hit and damage limit switch. Replace switch plate if switches do not operate correctly in both open and closed positions.

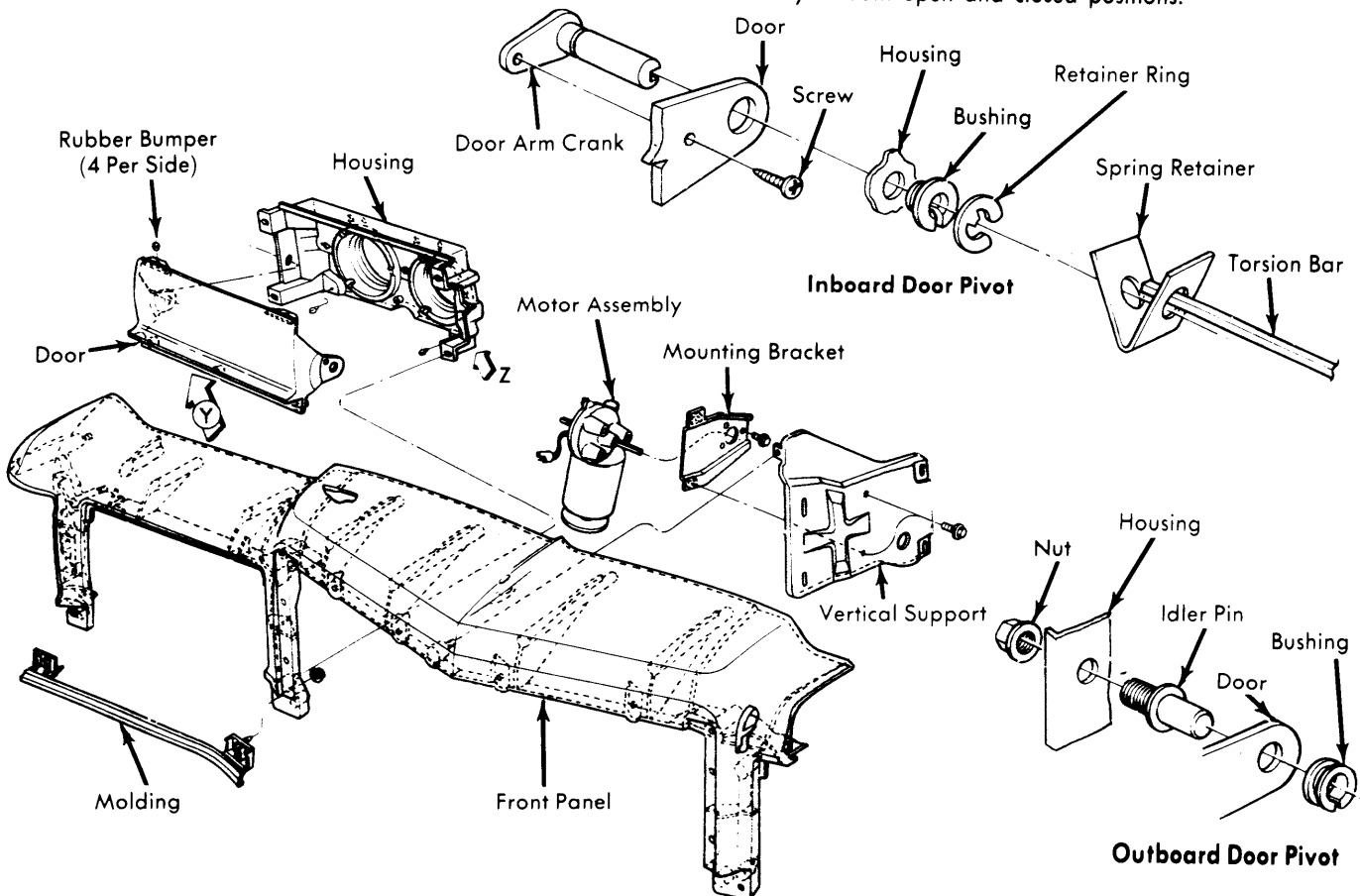

Fig. 1 Chrysler Corp. Headlight Door Assembly
(Royal Monaco Shown)

CHRYSLER CORP. (Cont.)

REMOVAL & INSTALLATION

TORSION BAR & MOTOR

Removal — Torsion bar and motor are removed as an assembly. Disconnect battery ground strap and motor leads (including ground wire) from harness. Rotate handwheel on motor until doors are at halfway open position. Compress and remove clips from crank assemblies and remove torsion bar from slotted areas in cranks. Remove motor mounting bracket from vertical lock support and remove torsion bar and motor as an assembly.

Installation — 1) Position motor on mounting bracket and install mounting screws. Verify motor is in half open position and tighten attaching screws 60 ± 15 INCH lbs. **CAUTION** — Do not bench test motor. Operating motor without load will damage motor. Insert torsion bar in motor and position clips on bar. **NOTE** — Torsion bar and hole in motor are rectangular and can be assembled only one way.

2) Position motor mounting brackets on vertical lock support and tighten attaching bolts to 220 INCH lbs. Position and fully seat torsion bar in slotted areas of cranks. Compress clips and position over cranks and torsion bar. Connect motor harness and battery ground strap. Test operation of doors.

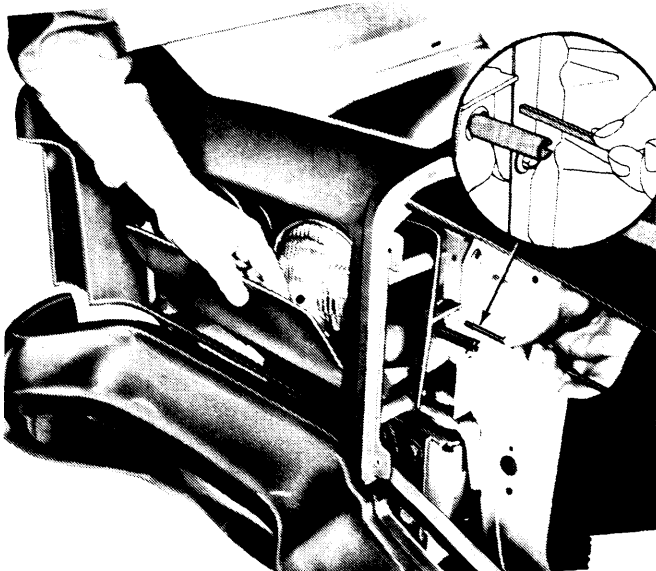

Fig. 2 Removing Torsion Bar

HEADLIGHT DOORS

Removal — 1) Disconnect motor leads at harness connector. Rotate motor hand wheel clockwise if doors are closed, or counterclockwise if doors are open, until headlamp doors are at half open position. Indicator lug on motor switch plate and lug on gear near rectangular hole will be in alignment. Compress torsion bar to headlamp door crank clip and slide clip from crank. Force torsion bar from crank arm slot by wiggling door up and down while pulling bar from slot.

2) Disconnect headlamp wiring and remove inner sealed beam unit. Remove retainer clip from crank assembly and screw retaining crank assembly to door arm at inboard side of door, then remove crank assembly from headlight door. Remove idler pin from housing. Remove four nuts holding housing to front panel, and on Imperial models only, remove brace holding housing to yoke, then slide housing rearward off mounting studs. With housing rearward, door may be removed through opening in front panel.

Installation — Reverse removal procedure and note the following: Before installing torsion bar in slotted area of crank, make sure motor is in half-open position. To check installation, operate doors several times and check for interference between doors and front panel. If interference exists, loosen headlight housing mounting nuts and readjust assembly until interference is eliminated. With all components properly installed, re-aim headlamps.

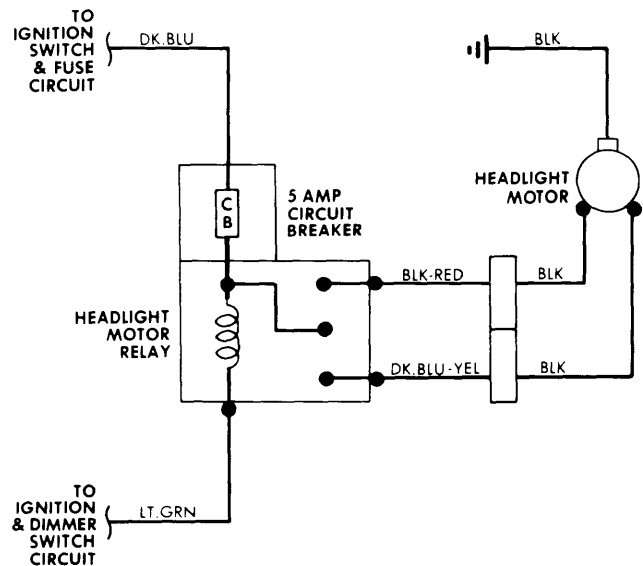

Fig. 3 Wiring Diagram of Chrysler Headlight Door Circuit