

GENERAL MOTORS AUTOMATIC – BUICK & CADILLAC

Buick – Electra, Riviera
Cadillac – All Models

NOTE – Also refer to General Motors Motor Actuated Door Locks in this section.

DESCRIPTION

The automatic door lock system uses the conventional power door lock system, but to accomplish the automatic feature the following additional components are used: Electronic logic module, two unlock relays, a lock relay, the back-up light switch, right and left front door lock remote control handle switches, and a drivers position seat sensor (Cadillac), or a left front door lock cylinder key switch (Buick).

Location of module is under instrument panel on left side and attached to center duct panel (Cadillac). On right side under instrument panel (Buick). Lock and unlock relays are taped to module except the Cadillac lock relay which is attached to left shroud inner panel near junction block. All switches and relays are serviced as assemblies, and the module is serviced as two assemblies (module case and harness; or the printed circuit).

OPERATION

Cadillac – With all doors closed and courtesy lights off, doors are automatically locked when driver is seated and transmission is shifted into "DRIVE".

Buick – With all doors closed and courtesy lights off, doors are automatically locked when transmission is shifted out of "PARK". Also, unlocking the drivers door using the key, will unlock all doors.

On all models, if transmission is in "Drive" and any passenger door lock is manually unlocked, or unlocked using the drivers remote control switches, all doors will automatically re-lock when passengers door is closed.

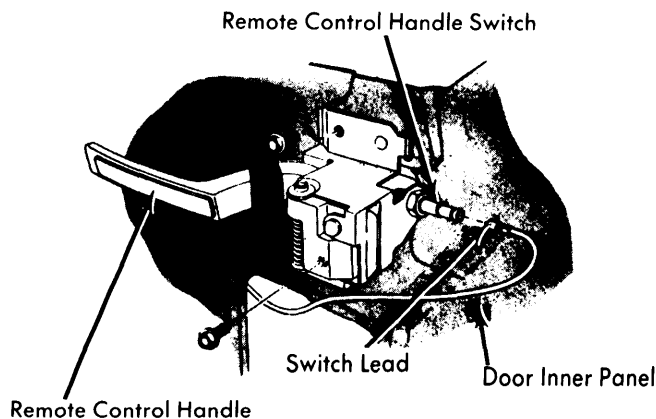

Fig. 1 Automatic Door Lock Remote Control Handle Switch

TESTING & TROUBLE SHOOTING

AUTOMATIC LOCKS INOPERATIVE BUT DOORS LOCK AND UNLOCK FROM CONTROL SWITCHES IN ARMRESTS

For access to module, see removal and installation in this story.

1) Occupy drivers seat, turn ignition "ON", place selector in "DRIVE", close all doors, and touch probe of self-powered test light to "G" terminal of module with test light grounded. If light does not come on, check Black wire from "G" terminal for proper ground.

2) If light came on, use test light and check for open circuit in Orange-Black feed wire between relays and source. If open circuit is found, repair circuit and recheck.

3) If relay source circuit is not open, connect test light between ground and module "M" terminal. If light comes on, replace module printed circuit.

4) If light remains off, check for open or short in Orange feed wire between module and source. Repair circuit and recheck.

NOTE – If circuit is shorted, body fuse will be blown and courtesy lights will not come on.

DOORS DO NOT LOCK AUTOMATICALLY WHEN SELECTOR IS MOVED TO DRIVE, BUT LOCK AND UNLOCK FROM CONTROL SWITCHES IN ARMRESTS. ALSO, FRONT DOORS UNLOCK AUTOMATICALLY BY ACTUATING EITHER REMOTE CONTROL HANDLE

1) Occupy drivers seat, turn ignition off, ground self-powered test light and touch probe to module "B" terminal. If light comes on, proceed to step 2). If light fails to come on, check seat sensor for proper ground (Black lead), check seat sensor for failure to close, and check Yellow-Black lead between seat sensor and module.

2) If light came on, place selector in "DRIVE", turn ignition "ON" and connect test light between ground and module "A" terminal. If light comes on, proceed to step 3). If light fails to come on, check for open circuits in neutral start switch Orange wire and Black-White wire from switch to module. Also check for faulty neutral start switch.

3) If light came on, place selector in "PARK", "N", or "R", and connect test light between ground and "L" terminal. If light fails to come on, replace module printed circuit. If light comes on, check lock relay ground. If ground is good, perform Lock Relay Test.

DOORS LOCK AUTOMATICALLY, BUT LEFT DOOR DOES NOT UNLOCK WHEN ACTUATING LEFT DOOR LOCK REMOTE HANDLE.

1) Place selector in "PARK" and lock all doors. Connect test light between ground and module "H" terminal. If left door does not unlock, proceed to step 2). If left door unlocks, check remote handle switch ground, remote handle switch for defects, or for open in wire between remote handle switch and module (Lt. Green-Black wire).

Door & Tailgate Locks

GENERAL MOTORS AUTOMATIC – BUICK & CADILLAC (Cont.)

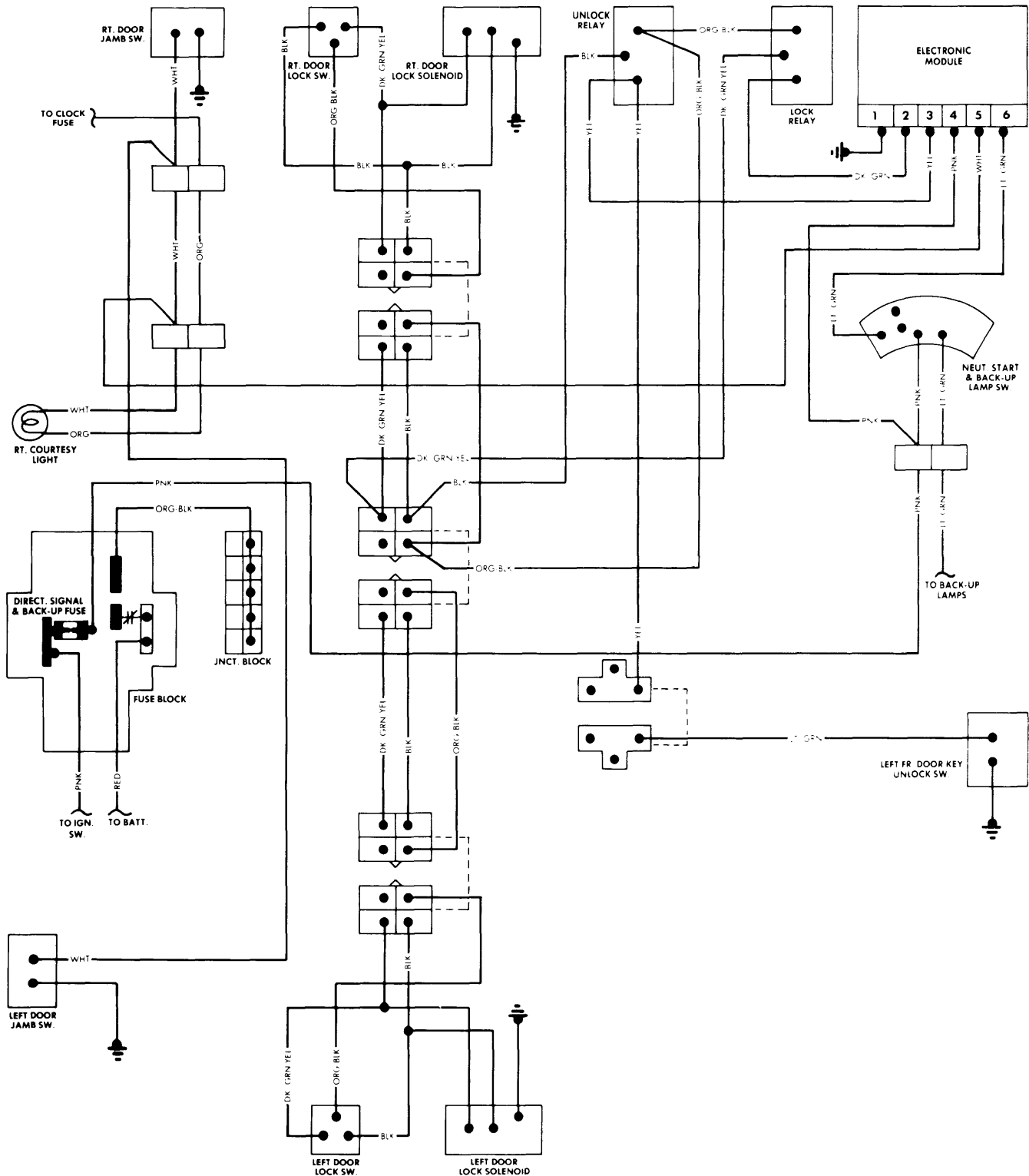

Fig. 2 Buick Automatic Door Lock Wiring Diagram

Door & Tailgate Locks

GENERAL MOTORS AUTOMATIC – BUICK & CADILLAC (Cont.)

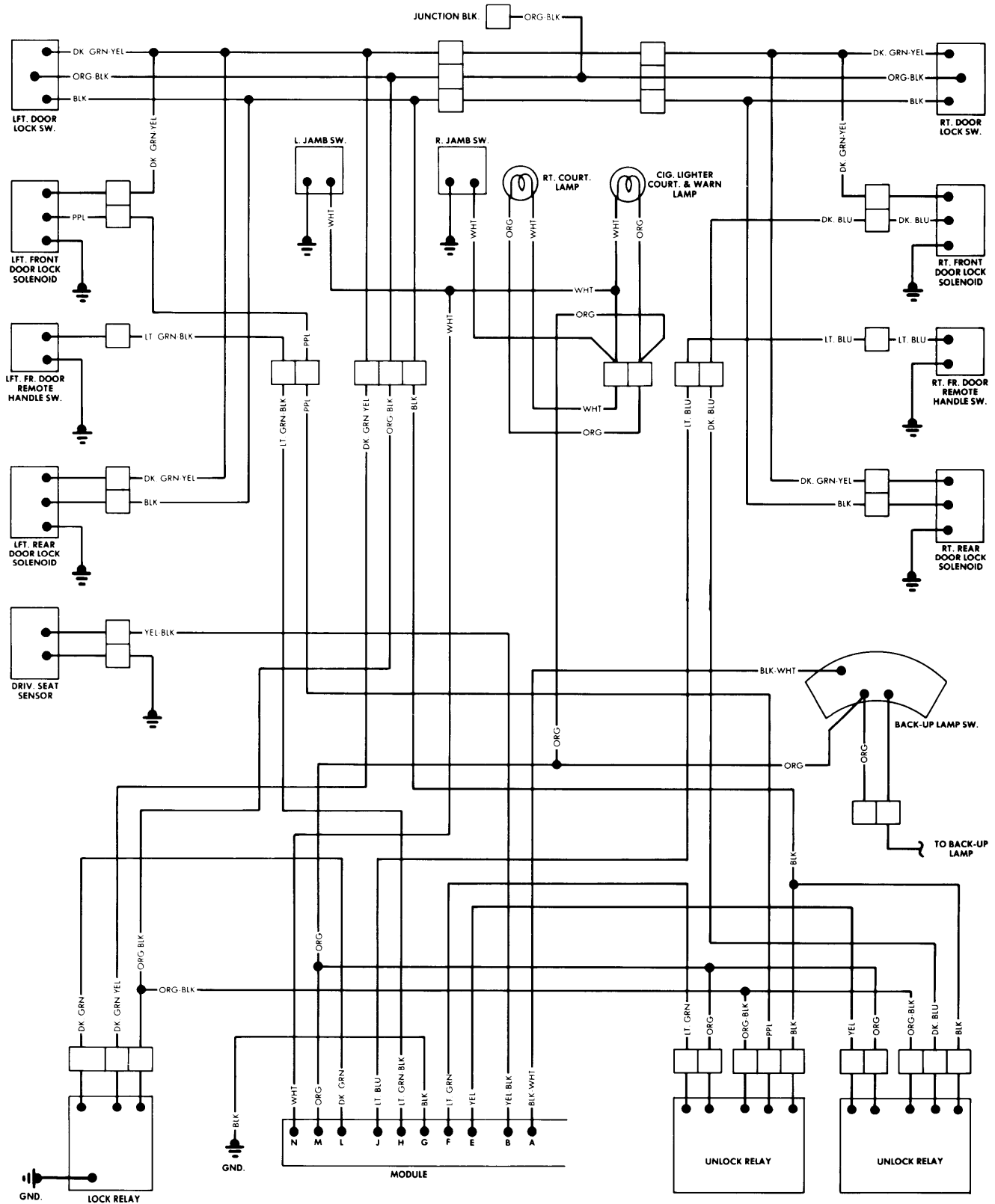

Fig. 3 Cadillac Automatic Door Lock Wiring Diagram

GENERAL MOTORS AUTOMATIC – BUICK & CADILLAC (Cont.)

2) If door did not unlock, turn ignition to "ON". Connect test light between ground and module "F" terminal. If door unlocks, replace module printed circuit. If door does not unlock, perform Left Door Unlocking Relay Test.

DOORS LOCK AUTOMATICALLY, BUT RIGHT DOOR DOES NOT UNLOCK WHEN ACTUATING RIGHT DOOR LOCK REMOTE HANDLE.

Follow left door lock remote handle test above, testing first the module "J" terminal, and then the "E" terminal. If right door does not unlock, perform Right Door Unlocking Relay Test.

DOORS LOCK AUTOMATICALLY WITH DRIVERS SEAT UNOCCUPIED AND SELECTOR LEVER IN "DRIVE"

Connect test light between ground and module "B" terminal. If light remains off, replace module printed circuit. If light comes on, check module to seat sensor Yellow-Black wire for grounded condition. Also check seat sensor for a failure to close condition.

DOORS LOCK AUTOMATICALLY WITH DOOR(S) OPEN AND SELECTOR LEVER IN "DRIVE"

Check for the following conditions: Open in door jamb switch circuit (White wire); Defective door jamb switch; Open in White wire between module and courtesy light circuit. If none of these conditions exist, replace module printed circuit board.

LOCKS DO NOT OPERATE AUTOMATICALLY OR FROM ARMREST SWITCHES

Check for opens or shorts in Orange-Black wire in the following circuits: Automatic Door Lock Circuit; Power Seat Circuit; Seat Back Lock Circuit.

DOORS LOCK AND UNLOCK AUTOMATICALLY BUT RIGHT OR LEFT FRONT DOOR FAILS TO UNLOCK FROM CONTROL SWITCH IN ARMREST

Perform appropriate (right or left) Unlock Relay Functional Test.

LOCK RELAY FUNCTIONAL TEST

1) With drivers seat occupied, doors unlocked, courtesy lights off, and transmission selector lever in "PARK", connect test light between ground and Dk. Green wire at relay. Move selector to "DRIVE". **NOTE** – *Relay must be grounded externally and all doors closed.* If light remains off, check for open in Dk. Green wire between relay and module.

2) If light came on momentarily in step 1), probe Orange-Black feed wire at relay. If light comes on, proceed to step 3). If light remains off, check for open in Orange-Black wire between relay and source.

3) Move selector to "PARK" and probe Dk. Green-Yellow wire relay terminal and move selector to "DRIVE". If light remains off, replace lock relay. If light comes on momentarily, then goes out and doors lock, relay is good. If all doors do not lock, check for open in Dk. Green-Yellow wire between relay and door lock solenoid.

UNLOCK RELAY FUNCTIONAL TESTS

NOTE – *Test for right and left unlock relays are the same except for wire color codes.*

1) Place selector in "PARK" and lock all doors from switch in armrest. Connect test light between ground and Yellow wire terminal (right), Lt. Green wire terminal (left) at relay. If door does not unlock, proceed to step 2). If door unlocks, check for open in wire between relay terminal just tested and module.

2) Probe Orange wire terminal at relay. If light comes on, proceed to step 3). If light failed to come on, check for an open in Orange wire between relay and source.

3) Probe Orange-Black wire at relay. If light comes on, proceed to step 4). If light remains off, check Orange-Black wire between relay and source for open condition.

4) Actuate door remote handle while probing Dk. Blue wire (right), Purple wire (left) at relay. If light comes on momentarily, proceed to step 5). If light fails to come on, replace door unlock relay.

5) Lock all doors. Unlock doors using armrest switch while probing Black wire terminal. If light comes on momentarily, proceed to step 6). If light failed to come on, check for open condition in Black wire between relay and lock switch(es) in armrest.

6) Lock all doors. Unlock doors using armrest switch while probing Dk. Blue wire (right), Purple wire (left) terminal. If light remains off, replace door unlock relay. If light comes on and door unlocks, unlock relay is good. If test light comes on but door does not unlock, check for an open circuit in Dk. Blue wire (right), Purple wire (left), between relay and front door lock solenoid.

REMOVAL & INSTALLATION

MODULE & RELAYS

Cadillac – Remove lower left steering column cover. Remove module bracket retaining screw and pull module downward. Remove unlock relays from module. Remove lock relay retaining screw to detach lock relay. **NOTE** – *Establish external ground for lock relay before testing.* To install module or relays, reverse removal procedure.

Buick – Remove module from behind glove box and remove relays from module as required. To install, reverse removal procedure.

Door & Tailgate Locks

GENERAL MOTORS AUTOMATIC – BUICK & CADILLAC (Cont.)

PRINTED CIRCUIT BOARD

Lower module and remove relays as required. Disengage locking tab on module housing and separate module halves. Insert small screwdriver into hole at edge of printed circuit board and pry out circuit board. To install, reverse removal procedure insuring circuit board terminals are fully seated.

BACK-UP LIGHT/NEUTRAL START SWITCH

Remove switch retaining screws from lower end of steering column. To install, reverse removal procedure. **NOTE** – Adjust

switch as outlined in Automatic Transmission Servicing in AUTOMATIC TRANSMISSION Section.

REMOTE CONTROL HANDLE SWITCHES

Remove upper and lower door trim panels as required. Remove switch from base of front door inside handle. To install, reverse removal procedure.

SEAT SENSOR (CADILLAC)

Information not available at time of publication.