

Door & Tailgate Locks

FORD MOTOR CO.

Ford Motor Co.
All Models So Equipped

DESCRIPTION

Power door lock systems use switches controlled by front door lock push buttons (Granada, Monarch, LTD II, and Cougar except XR7), or rocker type switches located in arm rests (all other models). Relays are used on Granada, Monarch, LTD II, and Cougar (except XR7) to direct current to doors and tailgate lock actuator motors.

TESTING

MOTOR TESTS

Apply 12 volts to one terminal of the motor's (actuator) connector and ground the other terminal. The motor gear should finish its travel in less than one second. Using an ammeter the motor current draw should not exceed 6 Amps.

SWITCH TESTS

Granada, Monarch, LTD II, & Cougar (Exc. XR7) – Using a self powered test light, there should be no continuity between any terminals on switch, when switch is in normal position. Continuity should exist between terminals "A" and "B" with switch held in one position and between "B" and "C" with switch held in other position.

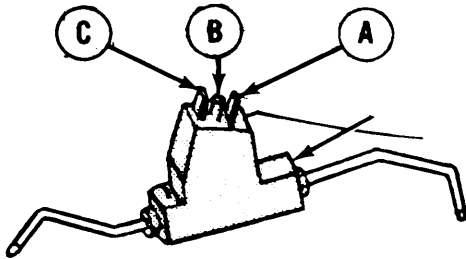

Fig. 1 Terminal Identification for Testing Lock Switch Granada, Monarch, LTD II, & Cougar (Exc. XR7) Shown

All Other Models – Procedure for testing the power door lock switch is the same for a single power window switch. See *Ford Electric Window Controls in ACCESSORIES & EQUIPMENT Section*.

RELAY TESTS

Granada, Monarch, LTD II, & Cougar (Exc. XR7) – Remove both connectors to perform relay tests. Relay is located on brake pedal support bracket. Verify that terminal "1" on each relay is grounded; if not grounded, check relay

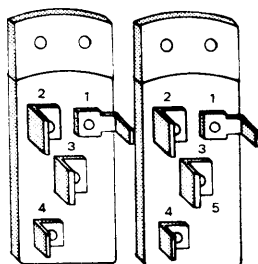

Fig. 2 Terminal Identification for Testing Relays

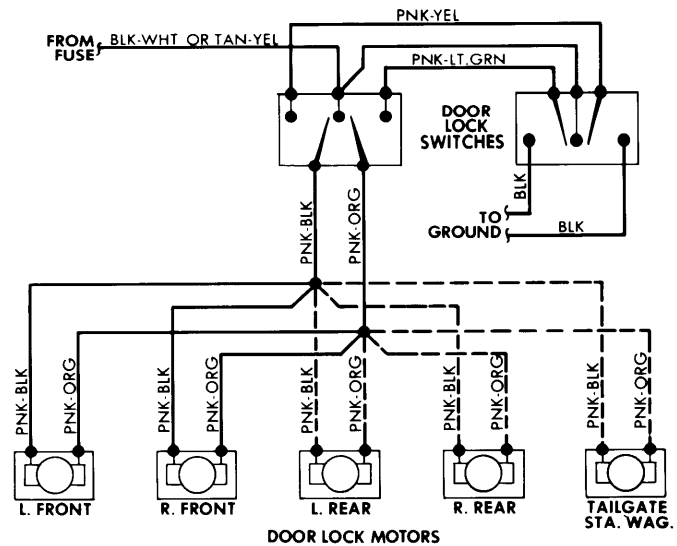

Fig. 3 Typical Power Door Lock Wiring Diagram for Ford, Mercury, Thunderbird, Cougar XR7, Continental, Mark V and Versailles

case-to-ground bolts for tightness. If relay ground bolts are tight and terminals "1" of each relay still do not ground, replace relay. Apply power to terminals "2" and "4" on each relay and connect a 12 volt test light between terminals "1" and "2" and ground (no longer than two minutes). Test light should come on; if not, replace relay.

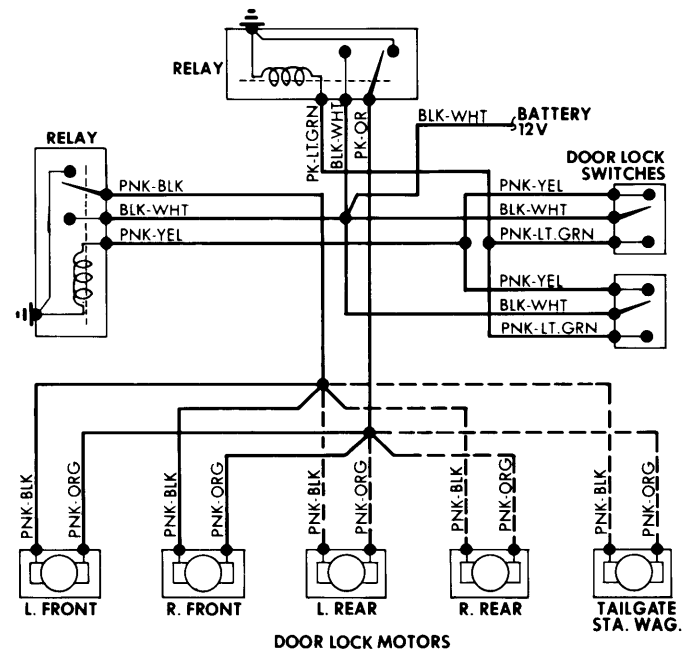

Fig. 4 Typical Power Door Lock Wiring Diagram for Granada, Monarch, LTD II, and Cougar (Exc. XR7)

FORD MOTOR CO. (Cont.)

REMOVAL & INSTALLATION

ELECTRIC DOOR LOCK ACTUATOR

All Models – Remove door trim panel and watershield. Disconnect actuator motor link from door latch. Remove screws or drill out pop rivets attaching actuator motor to door, and disconnect wiring at connector. Remove actuator motor. To install, reverse removal procedure.

DOOR LOCK CONTROL SWITCH

Granada, Monarch, LTD II, & Cougar (Exc. XR7) – Power door lock switch is an integral part of door lock push button rod. To remove switch, remove door trim panel and watershield. Switch must be detached from door latch or bellcrank before disconnecting or connecting wiring connec-

tor. Disengage push button rod from latch. To disconnect wiring connector, apply pressure under tab with small screwdriver, then pry up on locking tab. Remove switch. To install, reverse removal procedure.

All Other Models – Remove control panel from arm rest. Release connector attaching nuts and remove switch from control panel. To install, reverse removal procedure.

TAILGATE LOCK ACTUATOR

All Station Wagons – Remove tailgate trim panel and watershield. Remove two screws or drill out the two pop rivets retaining the lock actuator to tailgate inner panel. Disconnect lock actuator rod from latch, disconnect wiring, and remove actuator. To install, reverse removal procedure.