

AMERICAN MOTORS WINDOW DEFOGGER GRID

All Models

DESCRIPTION

Component systems consist of a grid and buss bars fused to inside of glass, a control switch, pilot light, and a timer relay. The feed wire to grid is attached to a separate wire harness which is connected to the defogger relay. Current feed to the relay is by a wire attached to the battery side of starter solenoid. A fusible link is included in this wire to protect circuit.

OPERATION

Actuating the defogger control switch on instrument panel (with engine running because of high current draw) causes defogger relay contacts to close. A timer, enclosed in relay case, will allow the defogger to operate for about 8 to 12 minutes, depending on the ambient temperature or when ignition is turned off. The system can be recycled by actuating control switch again.

TESTING

CONTROL SWITCH

Control switch can be checked by using an ohmmeter or a test lamp.

Ohmmeter Procedure — With yellow and white (Brown-Matador) wires disconnected from switch, connect ohmmeter across switch terminals. With switch in "OFF" position, ohmmeter should read infinity. With ohmmeter leads reversed, ohmmeter should read zero (or nearly zero). With switch depressed and held in "ON" position, ohmmeter should read zero.

Test Lamp Procedure — With yellow and white wires disconnected from switch, connect a jumper wire from accessory terminal in fuse panel to one switch terminal. Connect test lamp to other terminal and ground. With switch in "OFF" position, lamp should not light. With switch terminals reversed, lamp should not light. With switch in "ON" position, lamp should light with leads on either of switch terminals.

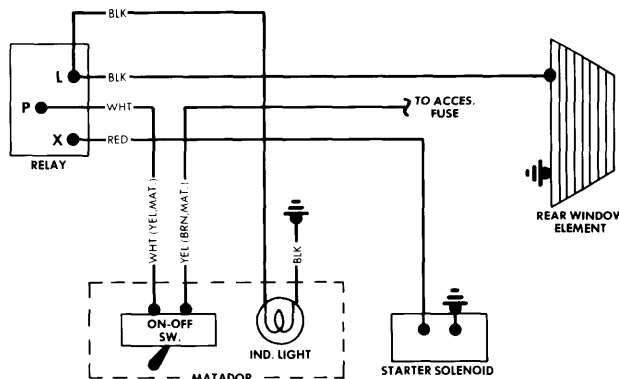

Fig. 1 American Motors Heated Rear Window Wiring

RELAY

1) Disconnect three wire connector at relay. Connect a jumper wire from accessory terminal on fuse panel to "X" terminal on relay. Connect another jumper wire from accessory terminal on fuse panel to yellow (Brown-Matador) wire terminal on switch. Connect a third jumper from white (yellow-Matador) wire terminal on switch to "P" terminal on relay.

2) Connect a 12 volt test lamp from "L" terminal on relay to a good ground. With ignition switch in "ACC" position, test lamp should light. With switch depressed to "ON" position, lamp should light and remain on for 7-13 minutes (Pacer), 8-12 minutes (All Others).

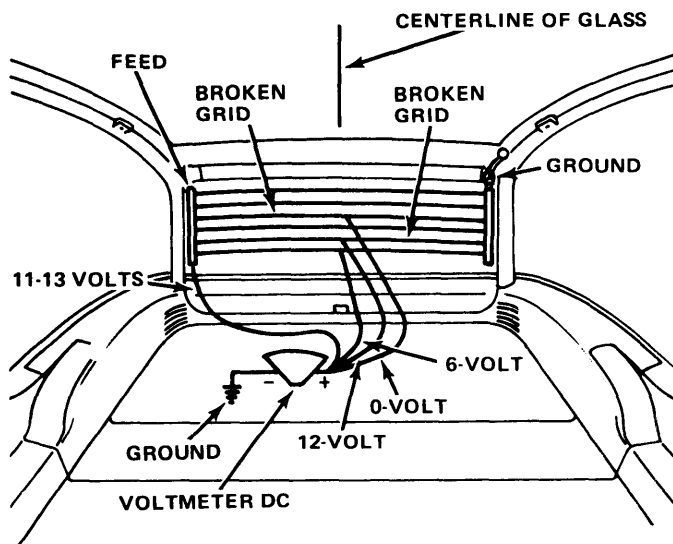

Fig. 2 Testing Pacer Window Grids Using Voltmeter By Checking Voltage Drop for Grid Continuity

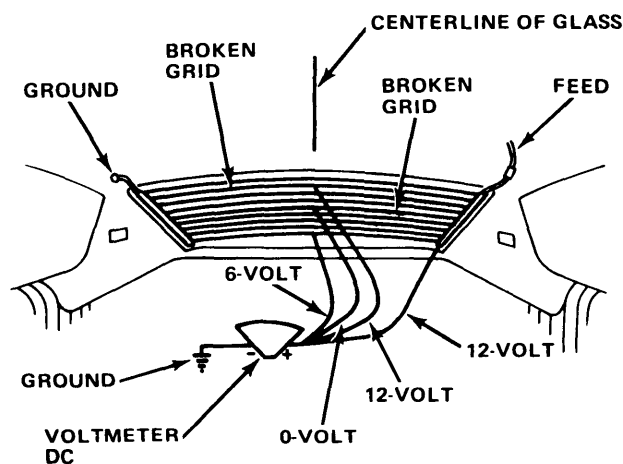

Fig. 3 Testing Gremlin, Hornet and Matador Window Grids Using Voltmeter By Checking Voltage Drop for Grid Continuity