

## GENERAL MOTORS – SQUARE MOTOR

**Buick  
Chevrolet  
Oldsmobile  
Pontiac**

*NOTE – Some models use depressed park wipers (wipers stop below hood line in park position). For these models, refer to General Motors – Round Motor story in this section.*

### DESCRIPTION

Wiper system design consists of a two speed rectangular shape motor with non-depressed park wiper arms. Motor is compound wound and attached to a gearbox containing a park switch. Motor control is obtained from wiper switch which has "OFF", "LO", and "HI" positions.

### OPERATION

**"LO" Speed** – Turning wiper switch to "LO" completes circuits from terminals one and three to ground (see illustration). Battery current flows through terminal two through series field and divides; current passes through armature to terminal one and to wiper switch ground. Current also passes through shunt field to terminal three and wiper switch ground.

**"HI" Speed** – Moving wiper switch to "HI" opens shunt field circuit to ground at switch; but the shunt field is connected to a 20 ohm resistor which is connected across terminals one and three. Shunt field current then flows from terminal three through resistor to terminal one, to switch and ground.

**"OFF" (Park)** – Parking circuit operates when wiper switch is turned off and wiper blades have not yet reached park position. When wiper blades are not in park position, parking switch contacts are closed and wiper will continue to operate until output gear is turned to a position where its cam opens park switch.

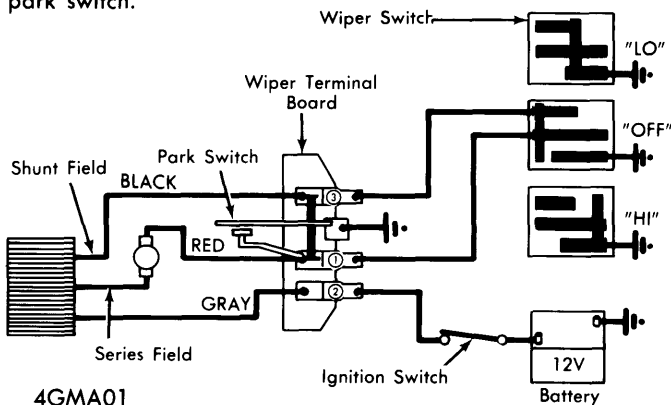

WIPER SYSTEM WIRING DIAGRAM

### TESTING

#### WIPER SYSTEM

**Preliminary Checks** – 1) Check harness connection at wiper motor and switch. Wiper motor and switch must be securely grounded. Check fuse. If connections and circuits check out, operate wiper in all modes. If system does not operate correctly, continue to step two.

2) Disconnect wiper motor connections and operate wiper motor with jumper wires (see illustration). If motor operates correctly after by-passing switch and harness, test system with motor on car. If motor does not operate, continue to step three.

3) Disconnect wiper linkage from motor crank arm and try jumper wire test again as in step two. If motor operates, check linkage for binds. If motor fails, remove motor and test motor circuits.

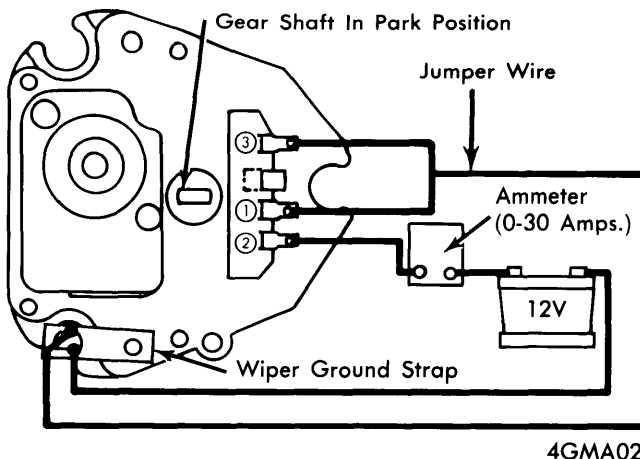

"LO" Speed – As Shown

"HI" Speed – Disconnect Jumper Wire From Terminal "3"

"OFF" – Leave Jumper Connected To Terminals "1" & "3", But Disconnect It From Ground Strap. Wiper Should Stop With Gear Shaft Flats As Shown.

### TESTS JUMPER WIRE CONNECTIONS

**Testing System (Motor On Car)** – 1) If wiper is inoperative or intermittent, check for an open circuit in feed wire (terminal "2" on motor), loose mounting of wiper switch, defective switch or open circuit in wire to wiper switch (terminal "1" on motor).

2) If wiper will not shut off, but has both "LO" and "HI" speeds, check for a grounded wire (terminal "1" on motor) leading to wiper switch.

3) If wiper will not shut off and has "LO" speed only, check for a defective wiper switch, open circuit in wire (terminal "3" on motor) to wiper switch.

4) If wiper will not shut off and has "HI" speed only, check for a defective wiper switch, open circuit in wire (terminal "3" on motor) to wiper switch.

5) If wiper has "HI" speed only, check for an open circuit in wire (terminal "3" on motor) to wiper switch.

6) If wiper has "LO" speed only, check for a grounded wire (terminal "3" on motor) to wiper switch or defective switch.

7) If wiper blades do not return to full park position, check for loose wiper ground strap connection.

**Testing Motor (Off Car)** – 1) If motor action is intermittent, check for a poor solder connections at terminal board, loose splice joints at brush plate. Check brushes binding in brush holder or open circuit in armature.

2) If motor will not shut off, but has normal "LO" and "HI" speed, check for a defective park switch, grounded RED lead wire.

# Windshield Wipers

## GENERAL MOTORS – SQUARE MOTOR (Cont.)

- 3) If motor will not shut off and has "LO" speed only, check for a grounded shunt field coil or grounded BLACK wire.
- 4) If motor will not shut off and has "HI" speed only, check for an open circuit in shunt field coil or open circuit in BLACK wire.
- 5) If wiper shuts off, but not in "PARK", check for a defective park switch or dirty contacts.
- 6) If speed is excessive in "HI", check for a defective resistor.

### WASHER SYSTEM TEST

Test procedure for washer unit is same as the G.M. Round Motor washer system. See *General Motors ROUND MOTOR Wiper System*.

## REMOVAL & INSTALLATION

### WIPER MOTOR

- 1) Raise hood, remove cowl screen on Camaro, Firebird, Apollo, Nova, Omega and Ventura models. Disconnect motor wiring.
- 2) Reaching through cowl opening, loosen (do not remove) transmission drive link attaching nuts from motor crank arm. Disconnect transmission drive link from motor crank arm.
- 3) Disconnect washer hoses, remove three motor mounting screws. Remove motor guiding crank arm through hole. To install, reverse removal procedure.

### WIPER ARMS

Remove wiper arm assemblies using suitable tools (J-22128 or J-8966) or equivalent to minimize possible windshield or paint damage. To install, reverse removal procedure.

### WIPER TRANSMISSION

- 1) Remove wiper arms and cowl vent screen or grille on Apollo, Camaro, Firebird, Nova, Omega and Ventura models. Disconnect wiring from wiper motor.
- 2) Loosen, do not remove, transmission drive link-to-motor crank arm attaching nuts, then disconnect drive link from motor crank arm. Remove right and left transmission-to-body attaching screws and on Vega models, remove transmission snap ring, hex nut and washer. Guide transmissions and linkage assembly out through cowl plenum chamber opening. To install transmission, reverse removal procedure using Loctite/75 adhesive kit on fasteners to secure. Torque transmission-to-body bolts to 48-72 INCH lbs. and hex head nut to 144-216 INCH lbs.

### MOTOR SPECIFICATIONS

Application	Specification
Operating Voltage.....	12V
Current Draw (No Load)	
"LO" Speed.....	4 Amps.
"HI" Speed.....	3.5 Amps.
Current Draw (Stall)	
Cold Motor .....	12 Amps.
Crank Arm Speed (Minimum)	
"LO" Speed.....	31 RPM
"HI" Speed.....	55 RPM