

FORD MOTOR CO. ELECTRIC

Ford Motor Co.
All Models

DESCRIPTION

NON-DEPRESSED PARK WIPERS

Granada, Monarch, Pinto, Bobcat, Maverick, Mustang, Comet — Wipers are actuated by a permanent magnet, rotary type electric motor. Two wiper arms and blades are mounted on a pivot shaft, one at each side of windshield. Pivot shafts are connected to the motor by linkage arms and attaching clips. The motor on Granada and Monarch utilizes an externally mounted diode which energizes the high and low speed brushes together, providing additional torque during high speed, partially dry windshield conditions.

DEPRESSED PARK WIPERS

All Other Models — Wiper motor is a two speed permanent magnet depressed park type with brush end plate at one end of housing and a gear housing at the other end. The park switch is located in gear cover and park mechanism is located in output arm.

INTERMITTENT WIPER GOVERNOR

All Models With Depressed Park Wipers — Intermittent operation of windshield wiper motor is controlled by a variable resistor in the windshield wiper control switch in conjunction with the electronic governor. This allows for a variable pause between wiping cycles. For intermittent operation, the wiper switch (exc. Ford, Meteor, Mercury), is rotated to the left. The more left rotation, the more resistance, thus more time is allowed between wipe cycles. On Ford, Meteor and Mercury, the wiper switch knob slides towards the right and the first position is for intermittent operation. On Granada, Monarch, and Mustang, the wiper switch knob slides to the right with the first detent being the intermittent operation. After placing knob in intermittent position, rotate time control knob clockwise to increase the pause between wipe cycles.

TESTING

WIPER MOTOR CURRENT DRAW

Depressed Park — Motor test can be performed on car with linkage disconnected or on bench. Connect ammeter as shown. Connect a jumper wire from battery negative post to low speed terminal on motor end plate and read current draw. Move jumper to high speed terminal and read current draw. In both cases, current draw should not exceed 3.5 Amps.

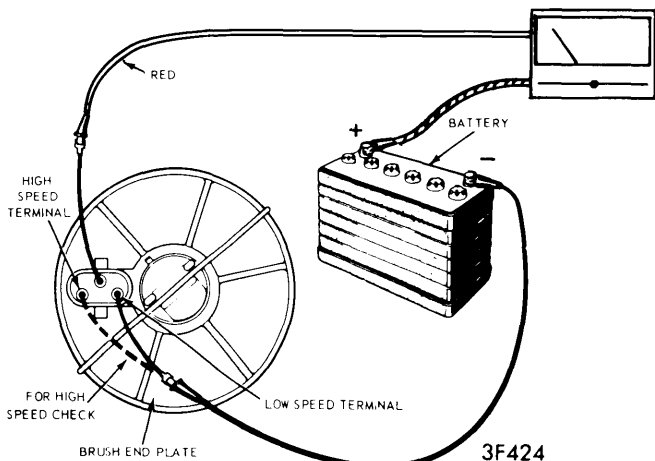

DEPRESSED MOTOR CURRENT DRAW TEST

Non-Depressed Park — Disconnect battery. Disconnect linkage from motor, and disconnect electrical plug to test motor on vehicle. Connect meter as shown. Current draw in high and low speed should not exceed 3 Amps.

NOTE — Before assuming a wiper motor or switch has failed on Granada and Monarch models, check diode. If diode is open, additional torque under high speed-dry windshield conditions will not be provided. If diode is shorted, motor will only run at one speed regardless of switch position.

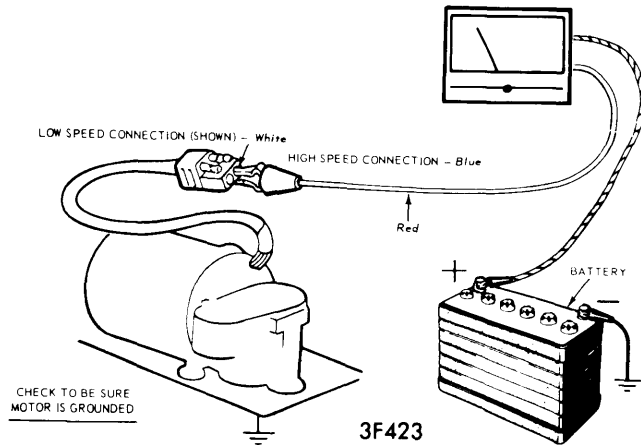

NON-DEPRESSED MOTOR CURRENT DRAW TEST

CIRCUIT BREAKER

All Models — Ford, Mercury, and Meteor have an 8 1/4 ampere circuit breaker in fuse panel. Mustang, Monarch, and Granada have a 6 ampere circuit breaker in fuse panel. All other models have a circuit breaker in the wiper control switch. All rotary pin terminal switches have a circuit breaker rating of 8 1/4 amperes and rotary blade terminal switches have a rating of 7 amperes. Slide switches have no circuit breakers.

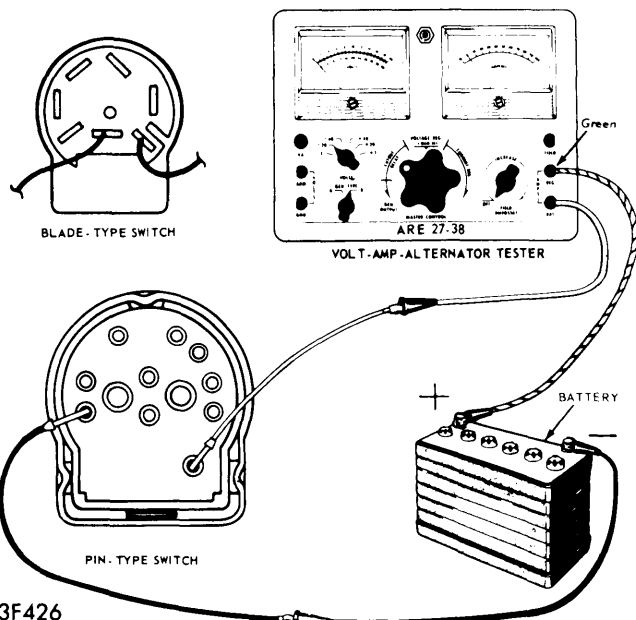

CIRCUIT BREAKER TEST

Before connecting leads, short them together and adjust current draw so that it equals circuit breaker rating. Connect meter as shown. Leave breaker connected to meter for ten minutes. Current reading should remain at rated current. If circuit breaker opens during the ten minutes it should be replaced.

Windshield Wipers

FORD MOTOR CO. ELECTRIC (Cont.)

Now adjust current draw to twice the rated current. The current reading on the ammeter should drop to zero within 30 seconds. If it takes longer than 30 seconds for breaker to open, it should be replaced.

WIPER SWITCH CONTINUITY TEST

All Models — Check continuity between switch terminals as shown in illustrations. Either a self powered test light or an ohmmeter can be used to test a standard switch. An ohmmeter must be used to test a switch used with the intermittent system. To detect marginal operation of the switch, rotate control knob while each reading is being taken. If switch does not exhibit continuity as shown or poor continuity exists, replace switch.

WIPER MOTOR PARKING TEST

Non-Depressed Park — Stop wiper system with ignition switch so blades are not in park position. Connect jumper wires as shown. The wipers should not run more than one full cycle then park. If motor will not park, or will not run to park, replace motor.

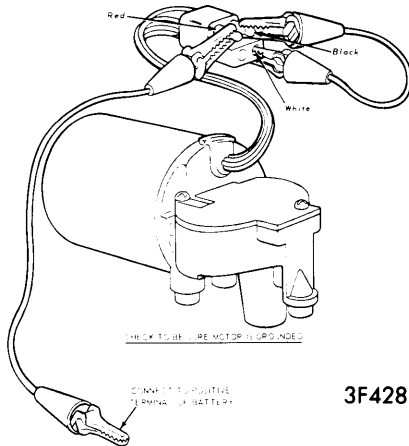

NON-DEPRESSED MOTOR PARK TEST

Depressed Park — Stop output arm about 90° past park position for this test. Make electrical connections (see illustration). With this hookup, the motor output arm should move in the following cycle: Rotate in normal direction. Reverse direction of rotation for about 10-15°. Stop rotating while crank pin is moved radially outward in a semicircular motion. Then finally stop in park position with current draw going to zero.

If output arm rotates in the reverse direction more than 15°, or if the motor stalls or jams while the output arm is rotating in the reverse direction replace the arm and windlatch assembly with the appropriate kit. If the motor does not run or does not park, check wiring connections at motor before removing motor from vehicle. For any other deviation, replace the gear cover and switch assembly with appropriate kit.

REMOVAL & INSTALLATION

WIPER MOTOR

Depressed Park Type (All Models) — Disconnect the battery. Remove wiper arm and blade assemblies. Remove left

cowl screen for access through cowl opening. Disconnect linkage drive arm from motor output arm crankpin by removing retaining clip. From firewall, disconnect wire connectors from motor. Remove three bolts retaining motor-to-firewall, and remove motor. If output arm catches on firewall during removal, hand turn arm clockwise so it will clear opening. Before installing motor, be sure output arm is in park position.

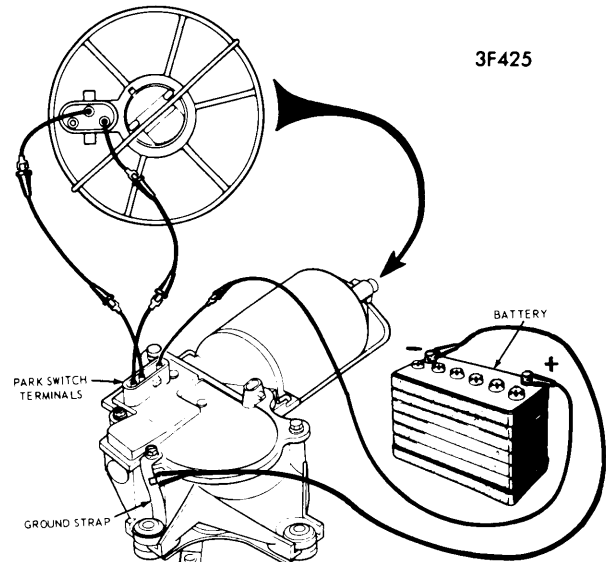

DEPRESSED MOTOR PARK TEST

Non-Depressed Park Type (Granada, Monarch, Maverick, Comet) — Disconnect battery. Remove evaporator case center distribution duct assembly (if equipped). Remove wiper motor pivot clip (work over top of brake support). Lift linkage from motor arm and remove motor from bracket. **NOTE** — Some Granada and Monarch models have an additional brace attached to floor pan, which must be detached and moved to one side to gain access to motor mounting bolts. To install, reverse removal procedure.

Non-Depressed Park Type (Pinto, Bobcat, Mustang) — Disconnect wiper pivot shaft and link assembly from motor drive arm ball. Remove three motor attaching screws and lower motor from under left side of instrument panel. Disconnect electrical leads and remove motor. To install, reverse removal procedure.

INTERMITTENT GOVERNOR

Remove governor after gaining access to it as follows: On Torino, Elite, Cougar, Montego, Thunderbird, and Continental Mark IV, remove instrument panel pad. On Lincoln, Ford, Mercury, Granada, and Monarch, reach behind left side of instrument panel. On Maverick and Comet, remove instrument cluster. On Pinto and Bobcat, remove fuse panel bracket (governor is mounted on back side).

WINDSHIELD WIPER SWITCH

Disconnect battery ground cable, remove switch knob (exc. Thunderbird and Mark IV), and on Ford and Mercury remove headlight switch knob. Remove wiper switch bezel, bezel nut, mounting plate or cluster finish panel as required. Remove switch and disconnect the electrical leads. To install, reverse removal procedure.

FORD MOTOR CO. ELECTRIC (Cont.)

WIPER SWITCH CONTINUITY TESTS

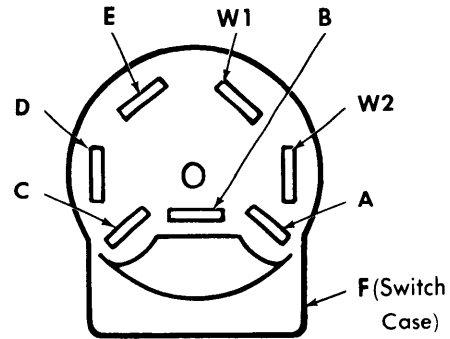
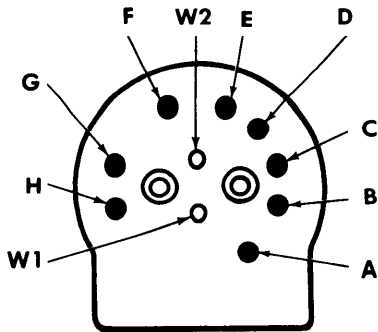

Pin Type Switch Connector Standard Wipers

Switch Position	Terminal Continuity
Off (Park).....	B-C, A-H, F-G
Low	C-D, A-G-H
High	D-E, A-G-H
Wash.....	W1-W2

Intermittent Wipers

Off (Park).....	B-C, A-H, F-G
Low	C-D-F-G, A-H
High	D-E-F-G, A-H
Intermittent.....	A-H, C-D-F
Wash.....	W1-W2
Variable resistance between F and G: Minimum of between 100-900 ohms, to a maximum of 5,600-8,400 ohms.	

Blade Type Switch Connector Standard Wipers

Switch Position	Terminal Continuity
Off (Park).....	C-D, A-B
Low	A-B-C
High	A-B-E
Wash.....	W1-W2

Intermittent Wipers

Off (Park).....	A-B, D-E
Low	A-B, D-E-F
High	D-E-F, A-B-C
Intermittent.....	E-F, A-B
Wash.....	W1-W2
Variable resistance between D and E: Minimum of between 480-720 ohms, to a maximum of 5,600-8,400 ohms.	

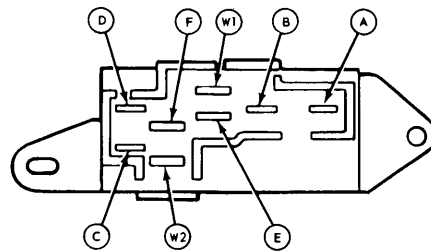
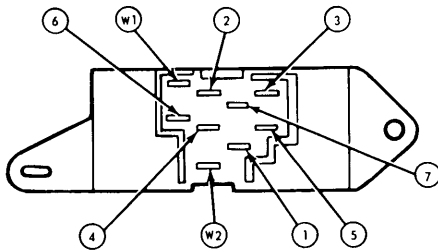

Blade Type (Slide Switch) Connector Standard Wipers

Switch Position	Terminal Continuity
Off (Park).....	1-5, 3-7
Low	1-4, 2-7
High	1-4, 2-6
Wash.....	W1-W2
Variable resistance between F and C: Minimum of between 100-900 ohms, to a maximum of 8,000-13,000 ohms.	

Blade Type (Slide Switch) Connector Intermittent Wipers

Switch Position	Terminal Continuity
Off (Park).....	A-E
Intermittent.....	B-E-F
Low	B-E-F-C
Wash.....	W1-W2
Variable resistance between F and C: Minimum of between 100-900 ohms, to a maximum of 8,000-13,000 ohms.	

Windshield Wipers

FORD MOTOR CO. ELECTRIC (Cont.)

WIPER SWITCH CONTINUITY TESTS (Cont.)

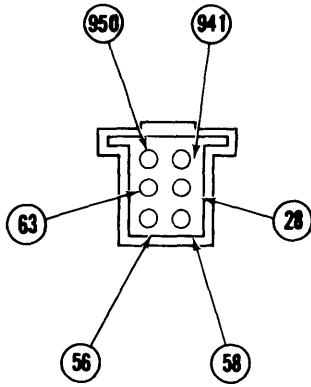

**Pin Type (Column Mounted Switch) Connector
Standard Wipers**

Switch Position	Terminal Continuity
Off (Park).....	28-58
Low	58-63
High	63-56
Wash.....	941-950
Variable resistance between 63 and 57 (with switch off): Between 1,000 ohms minimum to 5,000 ohms maximum.	

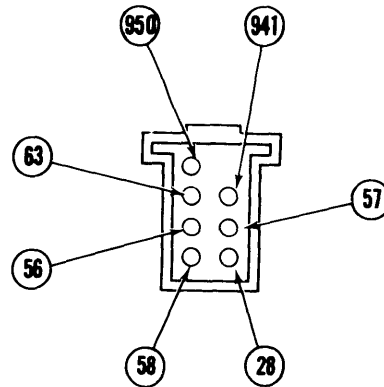

**Pin Type (Column Mounted Switch) Connector
Intermittent Wipers**

Switch Position	Terminal Continuity
Off (Park).....	58-63, 28-63
Intermittent.....	58-63
Low	58-63, 28-57
High	63-56, 28-57
Wash.....	941-950
Variable resistance between 63 and 57 (with switch off): Between 1,000 ohms minimum to 5,000 ohms maximum.	