

Power Seats

CHRYSLER CORP.

DESCRIPTION

Power seats adjust in six different directions. Seat tilt is controlled by front and rear levers on control switch. Center lever on seat switch controls vertical and horizontal movement. Seat is powered by a three armature reversible motor coupled through cables to rack and pinion assemblies located in seat tracks. The electrical circuit is protected by a 30 Amp. circuit breaker located on fuse block on inside cowl panel to left of steering column.

ELECTRICAL TESTS

If power seat malfunctions, a quick check may be made to isolate failure as either electrical or mechanical. With all harnesses connected and dome light on, operate master switch for direction of seat failure. If dome light dims, the seat motor is probably satisfactory, and mechanical jamming is indicated. If dome light does not dim, proceed with electrical tests.

CIRCUIT BREAKER

With test lamp, check for voltage at power feed terminal. If lamp lights, feed wire is okay. Connect test lamp to circuit breaker output terminal, if lamp lights, circuit breaker is okay.

WIRING HARNESS, CIRCUIT BREAKER-TO-SWITCH

Disconnect wire harness connector under seat. Connect a test lamp between RED and BLACK wire in female connector. If test lamp lights, harness is okay (see illustration).

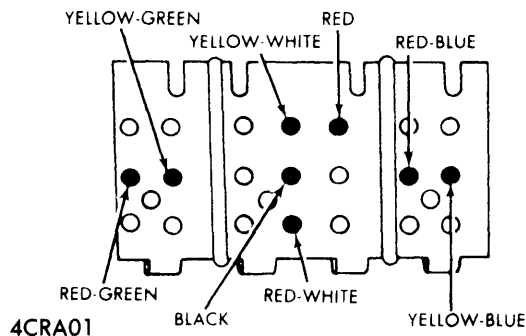

4CRA01 MASTER SWITCH CONNECTOR TEST POINTS

FRONT MOTOR

Connect a jumper lead between RED wire terminal in center section of connector and either the RED-GREEN or YELLOW-GREEN connection in front section (see illustration). Connect another jumper wire between black wire terminal in center section and open connection in front section. If motor does not operate, reverse jumpers in front section. If motor still does not operate, either harness or complete three motor assembly should be replaced.

CENTER MOTOR

Connect a jumper lead between RED wire terminal of center section of connector and either the RED-WHITE or YELLOW-WHITE terminal of center section. Connect another jumper between BLACK terminal and open terminal in center section (see illustration). If motor does not operate, reverse RED-WHITE and YELLOW-WHITE jumper connections. If motor still does not operate, either harness or three motor assembly should be replaced.

REAR MOTOR

Connect a jumper lead between RED wire terminal in center section of connector and either the RED-BLUE or YELLOW-BLUE terminal in rear connector section. Connect another jumper between the BLACK wire terminal in center section and open connection in rear section. If motor does not operate, reverse jumpers in rear section. If motor still does not operate, either harness or three motor assembly should be replaced.

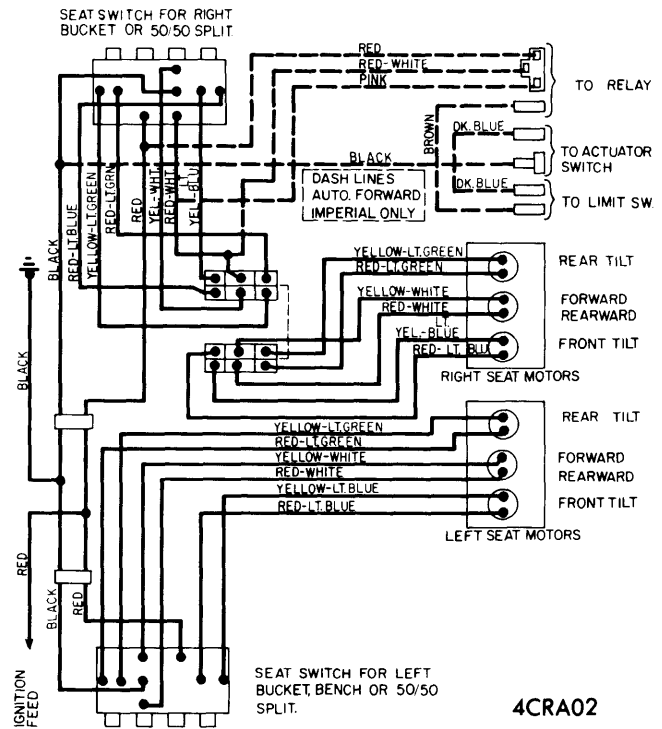

4CRA02 POWER SEAT WIRING DIAGRAM

CONTROL SWITCH

If motors and seat operate properly when switch is by-passed during electrical tests, the switch is defective and should be replaced.

COMPONENT REPLACEMENT

CAUTION — Whenever a motor, cable housing assembly, or vertical and horizontal transmission assembly require maintenance, the assemblies must be synchronized to ensure proper operation.

MOTOR

Removal — With battery disconnected, disconnect electrical leads and remove seat assembly from vehicle. Remove bolt securing motor to support, then remove motor mounting screws. Disconnect housings and cables from motor assembly, and remove motor.

Installation — Reverse removal procedure.

CHRYSLER CORP. (Cont.)

CABLE & HOUSING

It is recommended to remove motor assembly for ease of cable removal and installation. After motor removal, remove corbin clamp from cable housing, then slide cable and housing out of connector. To install, reverse removal procedure.

HORIZONTAL & VERTICAL TRANSMISSIONS

Removal — Remove seat assembly and motor. Fasten a 10" "C" clamp from mounting base assembly to upper channel assembly, just tight enough to keep it in place while removing cotter pin and front ($\frac{3}{16}$ ") clevis pin. With pin removed, slowly release tension on vertical spring. Remove cotter pin and rear

($\frac{3}{8}$ ") clevis pin and upper channel assembly, then remove horizontal spring. Remove through bolts from each end of side rail assembly and from transmission assemblies, then separate rails and transmission assemblies.

Installation — Position transmission assemblies between side rails and install through bolts. Locate roll pin and install through bolts in each end of assembly. Install horizontal spring. Position rail assemblies at each end of torsion bars, line up holes and upper channel and install rear ($\frac{3}{8}$ ") clevis pin and cotter pin. Insert vertical spring, install "C" clamp to line up holes in mounting base and upper channel, then install front ($\frac{3}{16}$ ") clevis pin and cotter pin. Install motor assembly and seat assembly in vehicle.