

ALL CAR MODELS

DESCRIPTION

Ignition switches are typically mounted on steering columns (exc. Chrysler Corp. vehicles with standard columns) and are actuated by ignition key locking mechanisms. Chrysler Corp. vehicles with standard columns have ignition switch and ignition key lock cylinder integral with lock housing below steering wheel.

LOCK CYLINDER

All Cars – Lock has two wing tabs and ignition key has large head for ease in grasping and improved operating leverage. Key can be removed only in “LOCK” position with ignition off and transmission engaged (automatic transmission in “PARK”, manual transmission in “REVERSE”). Steering wheel will be locked or will lock immediately when wheel is turned.

IGNITION SWITCH

All Models (Exc. Chrysler Corp. Standard Column) – Sliding type switch mounted on steering column and controlled by an actuating rod operated by the lock cylinder through a rack-and-sector mechanism. Up and down movement of actuator rod moves the switch slider back and forth within switch housing, establishing the various switch positions.

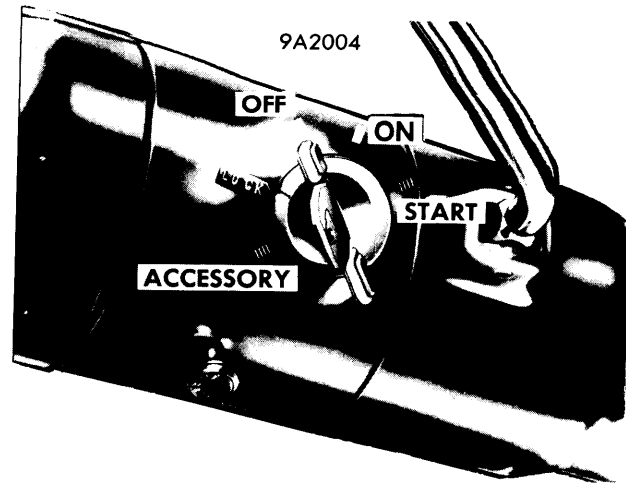

TYPICAL STEERING COLUMN LOCK

Chrysler Corp. Standard Column – Rotating type switch mounted directly across from lock cylinder and attached to it by a cam and pin. Switch turns directly with lock and key to establish the various switch positions.

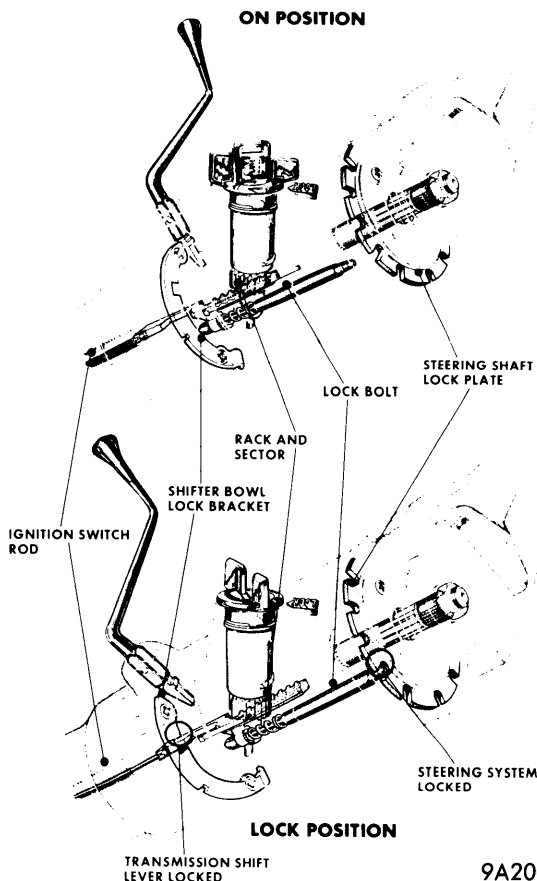

TYPICAL STEERING COLUMN LOCKING MECHANISM

OPERATION

Switch operation in each key position is detailed below. Ignition key can be removed only when switch is in “LOCK” position.

“Accessory”, “On” & “Start” – Switch operations are the same as on previous cars. Key will return to “On” position from “Start” when released.

“Off” – In this position, steering wheel and transmission shift linkage are unlocked and can be moved without having the engine running.

“Lock” – Key can only be moved to “Lock” position with transmission linkage in “PARK” or “REVERSE” when a slot in shifter bowl lock bracket (in steering column) is aligned with a raised step on the ignition lock actuating rod rack which allows the rack to move into the locked position. The step then locks the shifter bowl lock bracket to prevent shifting of the transmission. At the same time, lock cylinder moves a spring loaded lock bolt up into engagement with one of twelve slots in a lock plate splined on upper end of steering shaft. This action locks steering wheel (if lock bolt not aligned with a lock plate slot, spring will be compressed and lock bolt will engage slot as soon as steering wheel is turned slightly). If ignition key is left in ignition lock in this “LOCK” position, key warning buzzer will sound in usual manner when front door on drivers side is opened.

FLOOR SHIFT TRANSMISSION NOTE: On models with floor mounted shift linkage, steering column incorporates a shifter tube and lock bracket which is similar to that used with steering column mounted shift linkage. An interlock linkage (cable or rod) is used between the lower end of the shifter tube and transmission case shift lever to provide a back-drive so that ignition switch locking feature operates in same manner for all transmission types.

Ignition Switches

ALL CAR MODELS (Cont.)

SERVICING

Steering column must be lowered or removed for access to ignition switch on some vehicles. Steering wheel, directional signal and other components must be removed to gain access to lock cylinder retaining tab for lock cylinder removal. **CAUTION** — Steering columns are collapsible; special care must be taken to avoid bumping, jolting or hammering on steering shaft and gearshift tube. See *Steering Wheel, Horn Button, Turn Signal Switch and Steering Columns* in **STEERING** Section.

CAUTION — Some General Motors vehicles are equipped with Air Cushion Restraint Systems. If so equipped, disconnect battery ground cable and tape end before servicing steering column components. This must be done to prevent accidental release of A.C.R.S.

LOCK CYLINDER REMOVAL

NOTE — If lock cylinder retaining tab is not visible through hole (slot), clean flashing away to gain access to lock retaining tab.

American Motors — Key must be turned to "LOCK" position for cylinder removal. Insert a thin tool (small screwdriver or knife blade) into slot next to upper right switch mounting screw boss. Depress lock cylinder retaining tab, at same time pull lock cylinder out of housing bore.

Chrysler Corp. Standard Column — Place cylinder in "LOCK" position and remove key. Insert a small diameter screwdriver or similar tool into lock cylinder release hole. Push in to release spring loaded lock retainer and pull lock cylinder out of housing bore.

Chrysler Corp. Tilt-Wheels — Place cylinder in "LOCK" position. Insert a small screwdriver or similar tool into slot next to switch mounting screw boss (right-hand slot). Depress spring latch at bottom of slot and pull lock cylinder out of housing bore.

Ford Motor Co. — **NOTE** — Before attempting removal of lock cylinder place shift lever in "PARK" position on Auto. Trans. or "REVERSE" position on Synchro-mesh with Switch in "RUN" position. On fixed column units insert a wire pin in lock cylinder hole (see illustration) located inside column, half way down lock cylinder housing. On tilt column units insert a wire pin in hole located on the outside of flange casting (see illustration) next to emergency flasher button.

General Motors — Position lock assembly in "RUN" position, then insert a long thin screwdriver into slot next to switch mounting screw boss. Depress lock cylinder retaining tab and pull outward on lock assembly to remove.

LOCK CYLINDER INSTALLATION

American Motors — Hold lock cylinder sleeve and rotate cylinder clockwise against stop. Insert cylinder into housing with key on cylinder sleeve aligned with housing keyway. Lightly push cylinder against sector and rotate cylinder counterclockwise until cylinder mates with sector. Push in until cylinder retainer tab snaps into place and cylinder is secured.

Chrysler Corp. — Turn key to "LOCK" position and remove key. Insert cylinder into housing far enough to contact switch actuator. Insert key, press inward and rotate cylinder. When parts align, cylinder will move inward and a spring loaded retainer will snap into place, locking cylinder into housing.

Ford Motor Co. — Insert lock cylinder into cylinder housing in the flange casting and turn the key to "OFF" position. This action will extend lock cylinder retaining pin into the flange. Insert key in lock and cycle cylinder to insure correct operation in all positions.

General Motors — Hold lock cylinder sleeve and rotate key clockwise against stop (viewed from key end). Lay a $\frac{1}{16}$ " drill on housing surface next to housing bore. Drill prevents forcing lock cylinder inward beyond its normal latched position. Insert cylinder into housing bore with key on lock cylinder sleeve aligned to keyway in housing. Rotate knob counterclockwise. Maintain a light push inward on lock cylinder until drive section of lock cylinder mates with sector. Push in until spring latch pops into groove and lock cylinder is secured into housing. Remove drill and check freedom of rotation.

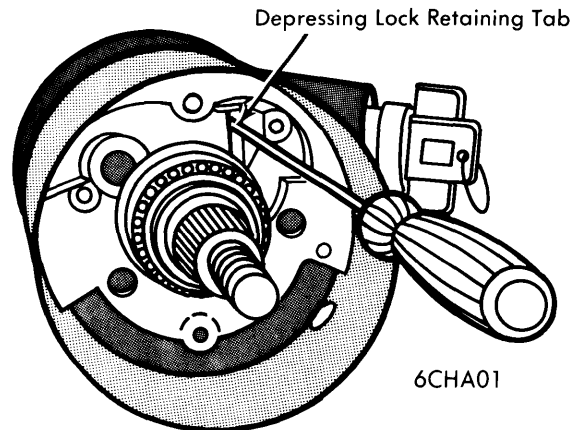

**LOCK CYLINDER REMOVAL
(AMC & GENERAL MOTORS)**

IGNITION SWITCH REMOVAL

American Motors — Place key lock in "OFF LOCK" position and remove switch mounting screws. Disconnect switch from remote rod, remove harness connector and remove switch.

Chrysler Corp. Standard Column — Remove three switch retaining screws from end of column and lift out switch.

Chrysler Corp. Tilt-Wheels — Place ignition switch in "ACC" position and remove switch mounting screws. Remove switch from column and actuating rod from switch.

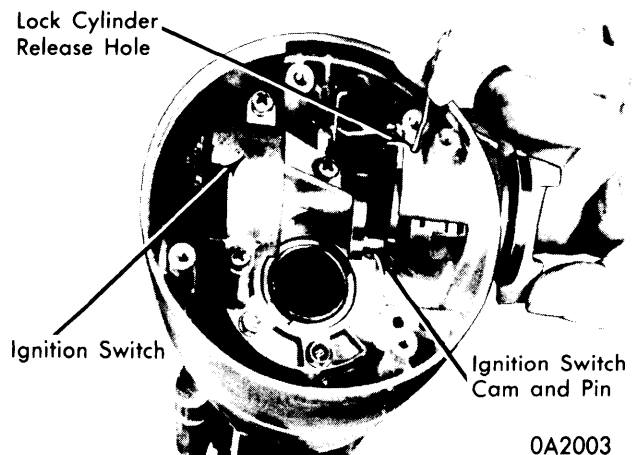

**TYPICAL CHRYSLER IGNITION SWITCH AND LOCK
(STANDARD COLUMN)**

ALL CAR MODELS (Cont.)

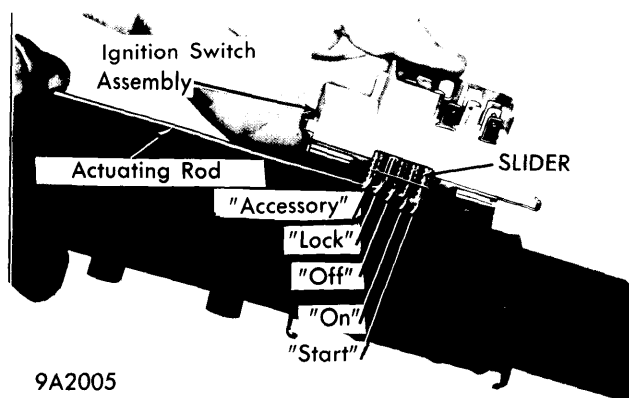

**TYPICAL IGNITION SWITCH
(EXC. CHRYSLER STANDARD COLUMN)**

Ford Motor Co. — Remove shrouding from steering column. Detach and lower column from brake support bracket. Disconnect battery cable. Disconnect switch wiring at multiple connector. Remove two nuts retaining switch to steering column. On models with pin-type multiple connector (Lincoln, Maverick, and Comet), detach switch plunger from switch actuator rod and remove switch. On spade-type multiple connectors (all other models), lift switch straight up to disengage actuator rod from switch.

General Motors — With steering column lowered or removed, ignition switch may be removed without removing steering wheel. Position switch in "LOCK" before removing. If lock cylinder has already been removed, the actuating rod to switch should be pulled up until it stops, then move rod down one detent, which is "LOCK" position. Remove switch screws and remove switch assembly.

IGNITION SWITCH INSTALLATION

American Motors (Standard Column) — With actuator rod disconnected, position switch over actuator rod and steering column. Move slider toward steering wheel placing switch in "ACCESSORY" position. Position actuator rod in slider hole and fasten switch to column being careful not to move slider out of detent.

American Motors (Tilt Column) — With actuator rod disconnected, position switch over rod and steering column. Move switch slider downward from steering wheel placing switch in "ACCESSORY" position. Position actuator rod in slider hole, place switch on column and lightly push switch down column to remove lash in rod, do not move slider out of detent; then tighten switch screws.

Chrysler Corp. Standard Column — Place ignition switch in center detent ("OFF" position). Feed wires down through space between housing and jacket. Position switch in housing and tighten three retaining screws.

Chrysler Corp. Tilt-Wheels — Place ignition lock in "ACC" position. Place ignition switch in "ACC" position by holding switch in left hand and actuator rod in right hand. Move slider to extreme left ("ACC" position). Fit actuator rod into slider and mount switch to column using two retaining screws. Push switch lightly down column to remove lash in actuator rod,

then tighten mounting screws to 35 INCH lbs. **CAUTION** — When tightening screws, do not move switch from detent position.

Ford Motor Co. — When installing switch, both locking mechanism at top of column and switch itself must be in "LOCK" position. To hold mechanical parts of column in "LOCK" position, place shift lever in Park (auto, trans.) or Reverse (manual trans.), turn key to "LOCK" position and remove key. Pull switch plunger out as far as it will go and then move it in one detent ("LOCK" position). Insert a 3/32" drill bit into locking hole on top of switch. Switch is now pinned in "LOCK" position. Connect switch plunger to actuator rod. Position switch on column and install retaining nuts (do not tighten). Move switch up and down to locate mid-position of rod lash, then tighten retaining nuts.

General Motors — Be sure lock cylinder is in "LOCK" position. Make certain switch is in "LOCK" position. Position switch on steering column making certain actuator rod end engages slot in switch slide. Install two mounting screws and tighten to 35 inch pounds. **CAUTION** — Use only specified screws to mount ignition switch. Use of other or longer screws could interfere with impact-compression of column.

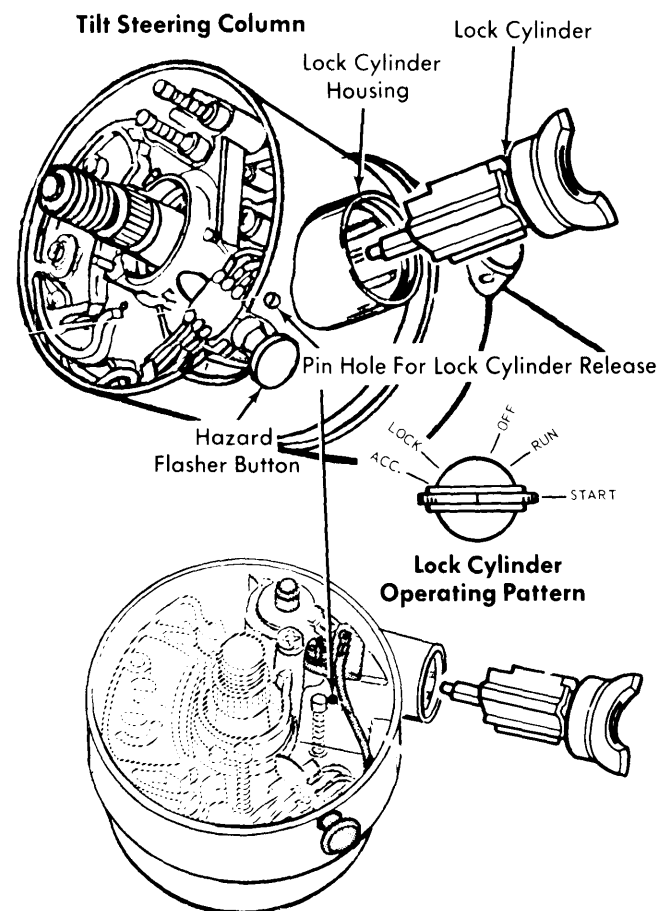

Fixed Steering Column

6FO01

FORD MOTOR CO. LOCK CYLINDER