

Automatic Headlight Dimmer

FORD MOTOR CO. AUTOMATIC HEADLIGHT DIMMER

Continental Mark IV
Lincoln Continental
Thunderbird

DESCRIPTION & OPERATION

The automatic headlight dimmer is a driver operated device which automatically switches headlights from high to low beam in response to light from an approaching vehicle or light from the taillights of a vehicle being overtaken. Major components of the system are as follows:

Sensor Amplifier — On Mark IV, unit is located between headlights on drivers side. On Lincoln, unit is located in engine compartment attached to left side of radiator. On Thunderbird, unit is located at upper corner of grille on drivers side. The unit is adjusted for sensitivity at factory and then sealed by an epoxy material to prohibit access to factory adjustment.

Power Relay — Provides heavy duty contacts for switching headlight beams. Relay contains a diode for damping purposes to protect sensor amplifier. Observe proper polarity when connecting relay to prevent diode damage.

Sensitivity Control — Driver sensitivity control is the ring knob on the headlight switch. Rotating the knob clockwise increases sensitivity and headlights will switch to lower beam when approaching car is farther away. Rotating knob counterclockwise decreases sensitivity, allowing approaching car to come nearer before headlight switching occurs. Full counterclockwise rotation allows for manual operation of headlight beams with foot switch.

Foot Dimmer Switch — Switch is a special dimmer override type that replaces standard switch. One switch position provides automatic control of headlight beams, other position is for low beam. With switch in automatic beam control position, a slight downward pressure on switch provides upper beam, regardless of amount of light on sensor-amplifier lens.

ADJUSTMENT

SENSOR-AMPLIFIER VERTICAL AIMING

Sensor Amplifier verticle aiming should be performed with car unloaded, trunk empty, gas tank at least half full, and tire pressure correct. Put car on a level floor and rock vehicle to equalize springs. Adjust vertical aiming screw at rear of bracket assembly (front of bracket assembly on Thunderbird) until the bubble is centered in the level. **NOTE** — Do not tamper with the screw at end of level. Always make final adjustment while turning aiming screw clockwise.

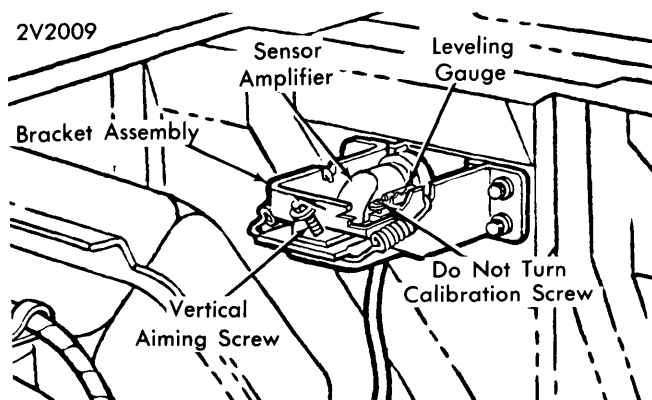

**SENSOR-AMPLIFIER ADJUSTMENT
(LINCOLN & MARK IV)**

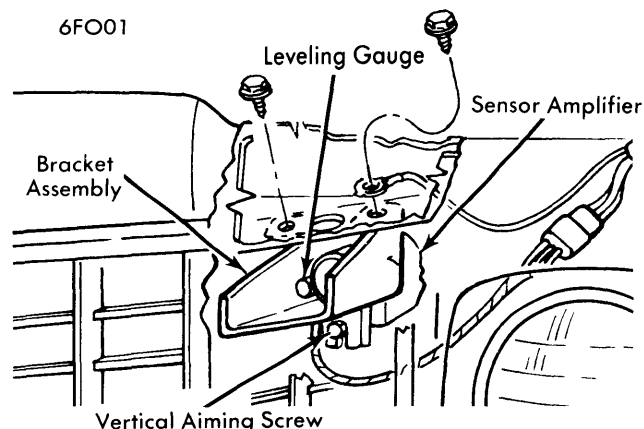

**SENSOR-AMPLIFIER ADJUSTMENT
(THUNDERBIRD)**

TROUBLE SHOOTING & DIAGNOSIS

HEADLIGHTS OCCASSIONALLY DIM AT WRONG DISTANCE

Approaching car lights out of adjustment. Fog, snow, or bright street lights.

HEADLIGHTS DIM TOO LATE OR NOT AT ALL

Driver sensitivity control not adjusted. Foot dimmer switch defective. Blown fuse.

HEADLIGHTS DIM TOO SOON

Driver sensitivity control not adjusted.

HEADLIGHTS WILL NOT GO TO UPPER BEAM

Defective photo amplifier, wiring, driver sensitivity control, or amplifier.

LOCKED ON LOW BEAM

Sensor amplifier verticle aim not adjusted. Defective foot dimmer switch or amplifier unit.

BEAM CHANGES ON DIFFERENT COLOR ROAD SURFACES

Sensor amplifier verticle aim is not adjusted.

TESTING

PREPARATION FOR TESTS

Unit is transistorized and requires no warm up time. Place car in lighted area, adjust driver sensitivity control to center position, and operate engine at fast idle to maintain constant voltage.

TEST PROCEDURE

- 1) Turn light switch on. Headlights should remain on lower beam in both positions of foot switch (beam should not change when foot switch is operated). If not make test A.
- 2) With foot dimmer switch in AUTOMATIC position, slight pressure on switch should override unit and switch headlight to upper beam. If not, make test B.

FORD MOTOR CO. AUTOMATIC HEADLIGHT DIMMER (Cont.)

TEST A (FUSE, DIMMER SWITCH, POWER RELAY, AMPLIFIER, DRIVER CONTROL)

- 1) Check for loose connection at foot switch, power relay, connector near driver control, or in line connector between sensor amplifier cable and wire harness.
- 2) Disconnect red wire (override) from foot switch. If lower beam is obtained in both positions, replace foot switch.
- 3) Disconnect sensor amplifier cable at in line connector. Make a test lamp from a No. 53 bulb and 2 pieces of wire. Ground one test lamp lead and touch the other to yellow terminal in connector. Test lamp should light. If not, check for blown fuse or loose connection at driver control connector or power relay.
- 4) Connect one test lamp lead to battery voltage and touch the other lead to white terminal in connector, then rotate driver control knob counterclockwise and bulb should light. If not, check for loose connection at driver control connector, or defective driver control (open circuit).
- 5) Connect one test lamp lead to battery voltage and touch the other lead to black terminal in connector. Operate foot switch two or three times. Test bulb should light in one position of foot switch, and headlights should be on lower beam for both positions. If not, check for loose connections at foot switch or power relay, a poor ground at power relay, or a defective foot switch or power relay.
- 6) If steps 1 through 5 do not locate problem, sensor amplifier is at fault and should be replaced.

TEST B (OVERRIDE CIRCUIT)

- 1) Check for disconnected red wire at foot switch.
- 2) Disconnect red wire from foot switch and ground it to car body. If lights switch to high beam, replace foot switch. If lights do not switch to high beam, check continuity of red wire to 2-way connector near driver control (3-way connector on Mark IV and Thunderbird which includes a ground connector.)
- 3) Disconnect sensor amplifier cable from inner-connecting harness at in-line connector, and using a test lamp, connect one lead to battery voltage and touch the other to white terminal in connector. Push down slightly on foot switch and bulb should light. If not, check continuity from in-line connector to foot switch.

4) Place foot switch in automatic position and cover sensor amplifier lens with a black cloth. The headlights should switch to upper beam. If not, disconnect sensor amplifier at in-line connector. If headlights switch to upper beam replace sensor amplifier unit.

5) With headlights on automatic lower beam, rotate driver sensitivity control all the way counterclockwise. Headlights should switch to upper beam. If not, check driver sensitivity control for poor ground.

6) If system responded to preceding test satisfactorily, system is operating properly. Check aiming and sensitivity for final adjustments.

REMOVAL & INSTALLATION

SENSOR-AMPLIFIER

Disconnect battery ground cable, and disconnect harness at rear of sensor amplifier unit. Do not pull on cable sheathing, this could result in damaged leads. Remove bracket assembly mounting screws and remove sensor amplifier from vehicle.

FOOT DIMMER SWITCH

Disconnect battery ground. Position left side of floor mat away from dimmer switch area. Remove attaching screws and lift switch from floor pan, remove leads and remove switch.

POWER RELAY

Disconnect battery ground and two plug connectors from relay. Remove attaching screws from brake pedal support and remove relay.

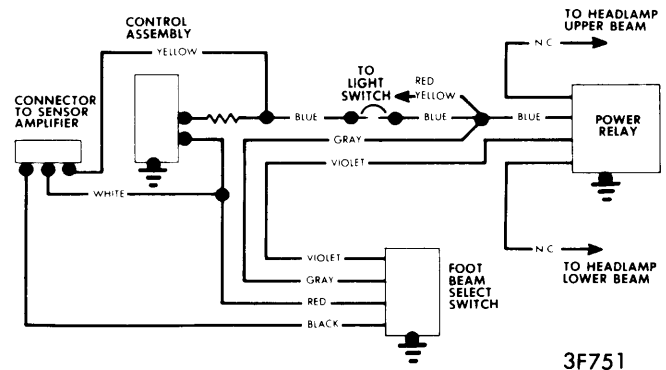

FORD MOTOR CO. HEADLIGHT DIMMER
WIRING DIAGRAM