

Automatic Headlights

GENERAL MOTORS TWILIGHT SENTINEL

**Buick
Cadillac
Oldsmobile**

DESCRIPTION

System automatically controls on-off operation of headlights, tail lights and instrument panel lights in response to amount of daylight in which car is being operated. A time delay control allows lights to remain on for a preselected period after ignition is turned off. Components location differs on individual car models as follows:

Buick — Photocell is mounted face up in windshield pillar post. Amplifier unit is mounted on lower instrument panel to right of steering column. The time delay and on-off switch is attached to light switch behind light switch knob.

Cadillac — Photocell is mounted face up under left front speaker grill. Amplifier unit is mounted on lower instrument panel brace. The time delay and on-off switch is attached to light switch behind light switch knob.

Oldsmobile — Photocell is mounted face up near right radio speaker grill on 88, Ninety-Eight, and Toronado; or on top surface of instrument panel above glove box on Cutlass. Amplifier unit is mounted on lower instrument panel to right of steering column. Time delay and on-off switch is attached to light switch behind light switch knob.

OPERATION

AUTOMATIC

1) Twilight Sentinel system will operate automatically when the ignition switch is on, the headlight switch is off and the control ring pointer is turned on (any position on the dial counterclockwise from "Off" position). The system will automatically turn lights on when daylight reduces to the point at which road illumination becomes necessary for safe driving. As daylight increases in the morning to the point at which road illumination is no longer necessary, it will turn lights off. The system is designed so lights will not go on or off when there are sudden changes in lighting such as going through tunnels, passing under bright lights, etc. This is accomplished by a 10-60 second delay before amplifier switches system either on or off.

2) A variable time-delay switch control permits driver to select a delay period of from a few seconds to a maximum of 1½ to 4½ minutes for headlights to go off after ignition switch is turned off. Additional lighting may be provided (during this period) by turning on cornering lights (if equipped). All lights will turn off automatically at end of time-delay period selected by driver.

MANUAL

If it is desired that lights be turned on during daylight hours, two methods may be used. Photocell assembly may be covered up and lights will turn on. This also allows lights to be turned off in normal manner when ignition is turned off. Lights can also be turned on using regular light switch after turning time-delay switch to "OFF" position.

TROUBLE SHOOTING

HEADLIGHTS TURN ON TOO LATE OR EARLY IN EVENING OR TURN OFF TOO EARLY OR LATE IN MORNING

Sensitivity adjustment incorrect.

LIGHTS WILL NOT TURN ON IN DARKNESS

Improper alignment of wiring harness connector at amplifier. Loose connection at light switch. Open wiring between fusible link and light switch. Inoperative light switch (circuit breaker). Open ground path through on-off switch of time delay control assembly. Inoperative photocell or amplifier.

LIGHTS WILL NOT TURN OFF IN DAYLIGHT

Amplifier Sensitivity control maladjusted. Missing photocell, poor contact between photocell and socket, or socket assembly fallen out of mounting hole. Inoperative photocell or amplifier.

LIGHTS WILL NOT TURN OFF AFTER IGNITION IS OFF

Ignition line not at ground potential in off position. Inoperative time delay control assembly. Open wiring in circuit. Inoperative amplifier.

LIGHTS WILL NOT STAY ON FOR 1½ -4½ MINUTES AFTER IGNITION IS OFF

Inoperative time delay control assembly. Blown taillight fuse. Improper resistance at amplifier connector. Short in wiring circuit. Inoperative amplifier.

WARNING BUZZER WILL NOT OPERATE

Open wiring in buzzer circuit. Inoperative door jam switch. Bad connection at light switch. Inoperative amplifier.

TESTING & DIAGNOSIS

NOTE — Make sure time-delay control is "ON", photocell is not obstructed, lighting system operates correctly manually, manual headlight switch if off, and that fuses are not blown.

SYSTEM CHECK

- 1) With light and ignition switches "Off" and Sentinel "On", cover photocell and turn ignition on. Lights should turn on within 10 seconds.
- 2) Remove cover from photocell and shine bright light (flashlight) on photocell. Lights should turn off within 10-60 seconds.
- 3) Cover photocell again and allow time (10-60seconds) for lights to turn on. Turn ignition switch off and lights should remain on for 1½ -4½ minutes and then turn off.
- 4) With ignition off and key removed (to prevent ignition buzzer from sounding), turn regular light switch to park or headlight position. Open a door and warning buzzer should sound.
- 5) Satisfactory performance of tests 1 through 4 indicates unit is operating properly. If unit is operating properly but turn on time is incorrect, make minor Sensitivity Adjustment.

GENERAL MOTORS TWILIGHT SENTINEL (Cont.)

ADJUSTMENT

SENSITIVITY ADJUSTMENT

NOTE — If amplifier has a label affixed to it, adjust amplifier as outlined on label. If amplifier does not have a label, use following procedure for sensitivity adjustment.

If a photocell or amplifier is malfunctioning, both must be replaced as a matched set since no provision is made for adjusting a mismatched set. However, if turn-on or turn-off time is not correct, a recommended procedure to advance or retard time by fifteen minutes is used. Adjust amplifier as follows:

Headlights On Too Late, Off Too Early — With ignition and lights turned off, cover photocell to block out light. Check

resistance between terminals "J" and "L" on amplifier connector, with time delay in any on position. Record resistance reading. Adjust control adjustment screw on amplifier until resistance reading is 1/2 of previous reading. If amplifier has been previously adjusted, set resistance to 4100-4500 ohms.

Headlights On Too Early, Off Too Late — Follow same procedure, except adjust control adjustment screw on amplifier until resistance reading is 1 1/2 times previous reading. Again, if amplifier has been previously adjusted, set resistance to 4100-4500 ohms.

Sensitivity
Adjustment
Control Screw

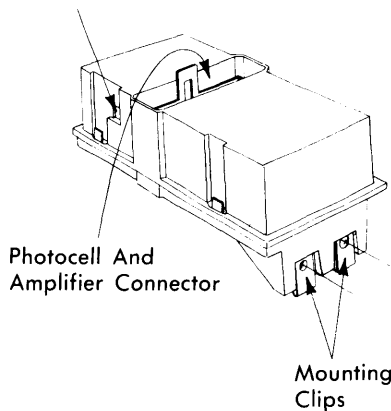

4BU01

SENSITIVITY ADJUSTMENT CONTROL SCREW

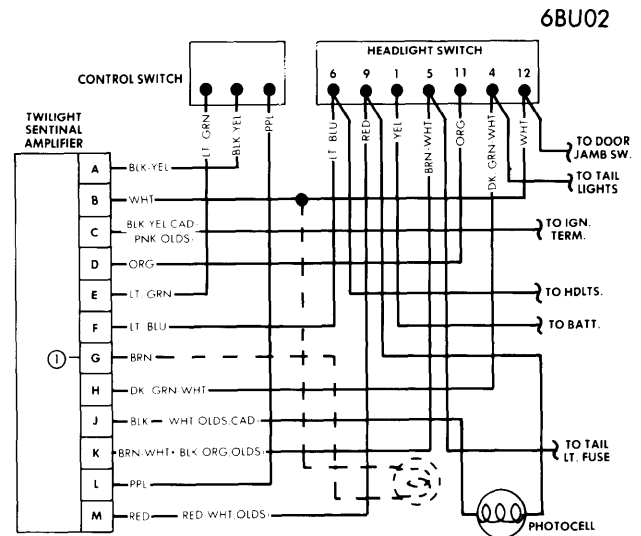

① — Oldsmobile Only — Headlight Warning Lamp.

GENERAL MOTORS TWILIGHT SENTINEL CIRCUIT