

Automatic Speed Controls

FORD MOTOR CO.

Ford Motor Co.

DESCRIPTION

Speed control system consists of an "ON-OFF" switch and "SET-ACC" and "COAST" switch, servo assembly, sensor, amplifier, vacuum reservoir, wire harness, and vacuum hoses to connect components. The switches are located in steering wheel spokes. The amplifier is located under the instrument panel, and the servo assembly is located in the engine compartment. The sensor is located in the engine compartment on Thunderbird, Lincoln, and Continental Mark IV; and under the instrument panel on all other models.

OPERATION

This system is operational at speeds of 30-80 MPH. When "ON-OFF" switch is actuated to "ON" position and driver depresses and releases "SET-ACC" button, vehicle speed will be maintained until a new speed is set by driver or brake pedal is depressed.

TESTING

CONTROL SWITCH

NOTE — In following testing procedures, reference is made to primary wire colors only.

1) Disconnect six-way connector at amplifier. Check battery voltage at lt. blue wire when "ON" switch is depressed. Battery voltage should be available from lt. blue wire leading from control switches.

2) Connect an ohmmeter between blue wire and ground. Check wire for continuity to ground when the "OFF" switch is depressed. If a resistance higher than 1 ohm is found, the wiring, slip rings, or switch is at fault, or steering column is not properly grounded. To check steering column ground, connect an ohmmeter to good body ground and steering column upper flange. Resistance should be less than 1/2 ohm. Rotate steering wheel and if equipped with tilt column, move up and down. If resistance higher than 3 ohms is noted, clean horn brush contacts and ground brush. A resistance less than 1 Ohm must be obtained before performing remaining tests.

3) With ohmmeter connected between blue wire and ground, depress set-speed switch. A reading of approximately 680 ohms should be indicated on ohmmeter. Depress coast switch, a reading of approximately 120 ohms should be indicated on ohmmeter.

SPEED SENSOR

Disconnect sensor wires from amplifier and connect an ohmmeter between wire connector terminals (green & black). A reading of about 40 ohms should be obtained. A reading of 0 ohms indicates a shorted coil and a maximum reading indicates an open coil. Replace sensor in either case. If reading is 40 ohms and speedometer operates properly, speed sensor is probably good. A new sensor should be substituted in place of old sensor to check for proper operation.

SERVO ASSEMBLY

1) Disconnect ball chain from throttle linkage. Separate servo to amplifier connection, then connect an ohmmeter between the orange and grey wire leads at servo connector. A resistance of approximately 85 ohms should be obtained. Connect ohmmeter between orange and white wire leads. A resistance of approximately 85 ohms should be obtained. Start engine, with servo disconnected from amplifier, connect orange lead of servo to battery positive terminal. Connect white lead of servo to ground, and momentarily touch grey

lead of servo to ground. Servo throttle actuator should tighten bead chain and open throttle. Throttle should hold in that position or slowly release tension on chain.

2) When white wire is removed from ground, servo should release bead chain tension immediately. Replace servo if it fails any of the above tests. **CAUTION** — If orange lead is shorted to either white or grey leads, it may be necessary to replace the amplifier.

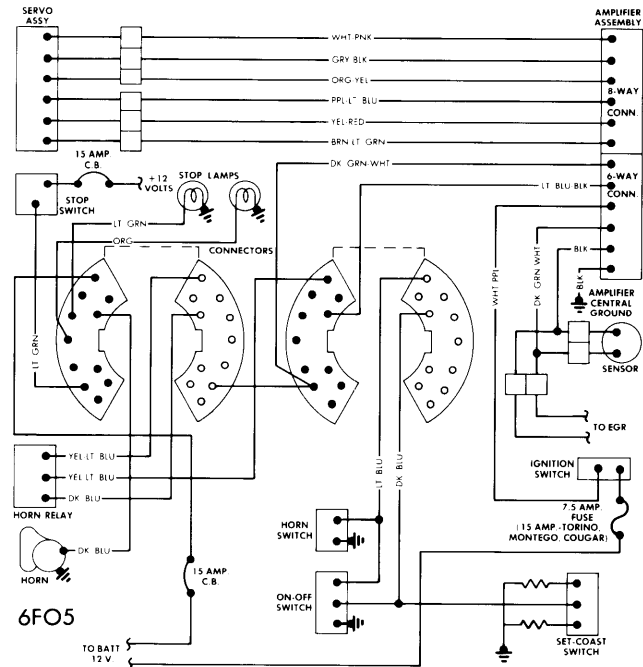

**FORD MOTOR CO. SPEED CONTROL WIRING
(EXC. GRANADA, MONARCH, THUNDERBIRD,
LINCOLN & MARK IV)**

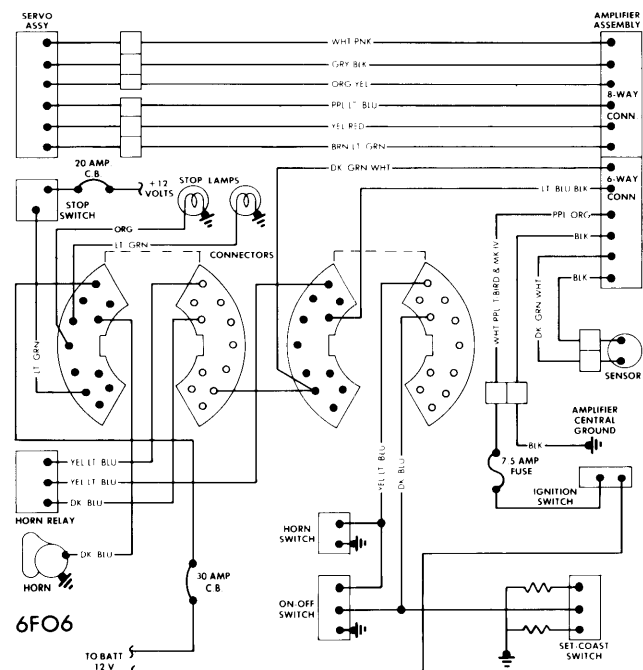

**FORD MOTOR CO. SPEED CONTROL WIRING
(THUNDERBIRD, LINCOLN & MARK IV)**

FORD MOTOR CO. (Cont.)

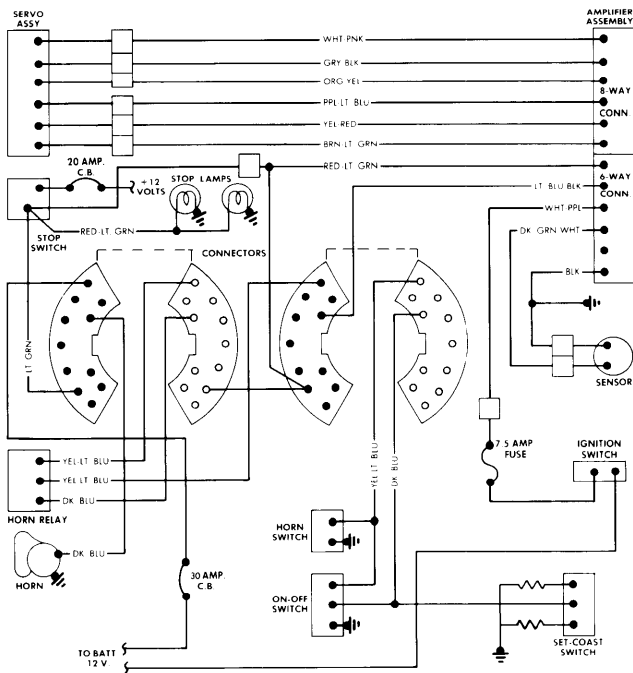

6F07

**FORD MOTOR CO. SPEED CONTROL WIRING
(GRANADA & MONARCH)**

AMPLIFIER

CAUTION — DO NOT use a test light to perform amplifier tests as excessive current draw will damage electronic components. Use only a voltmeter of 5000 ohm/volt rating or higher.

1) Turn ignition "ON" and connect a voltmeter to blue lead at amplifier 6-way connector. Voltmeter should read 12 volts when the "ON" switch in steering wheel is depressed and held. If no voltage is available, check horn relay circuit and perform Control Switch Test. Release the "ON" button; 12 volts should remain at blue wire indicating the "ON" circuit is engaged. If voltage does not remain, check for ground at amplifier, fuse and/or circuit breaker. Insert a known good amplifier and recheck "ON" circuit if necessary.

2) With ignition "ON" and voltmeter connected to blue wire as in step 1), depress the "OFF" switch on steering wheel. Voltage on blue wire should drop to zero indicating "ON" circuit is de-energized. If voltage does not drop to zero, perform Control Switch Test. If switches test good, install a known good amplifier and retest.

3) With ignition "ON", and voltmeter connected to blue wire as in step 1), depress the "ON" switch, then hold "SET-ACCEL" button on steering wheel. Voltmeter should indicate approximately 10 volts. Rotate steering wheel and watch voltmeter for variation. If voltage varies more than .5 volt, perform Control Switch Test.

4) With ignition "ON", and voltmeter connected to blue wire as in step 1), depress the "ON" switch, hold "COAST" button down on steering wheel. Voltmeter should indicate about 6 volts. If all functions check good, perform Servo Test, and Sensor Tests, and insert a known good amplifier and recheck. **CAUTION** — Do not substitute a new amplifier until actuator coils have been tested. See Servo Assembly Tests.

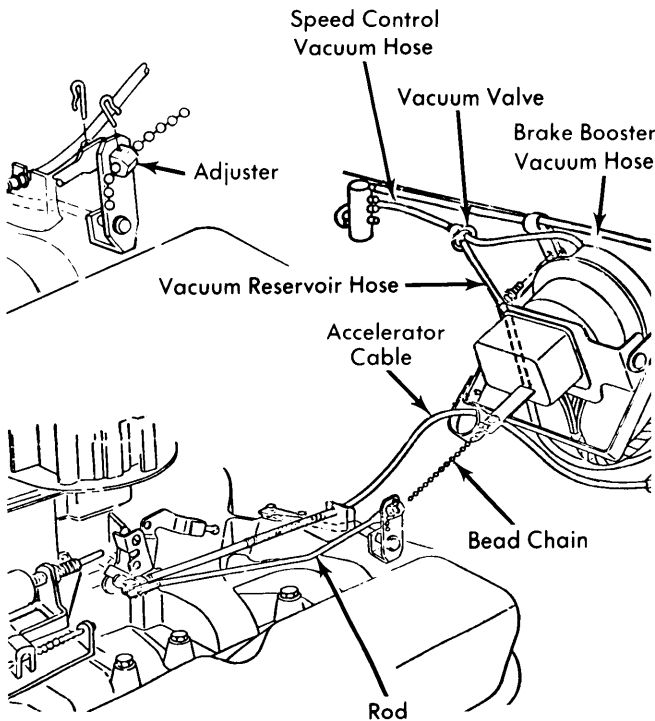

6F01

**SPEED CONTROL SENSOR & SERVO
(FORD & MERCURY)**

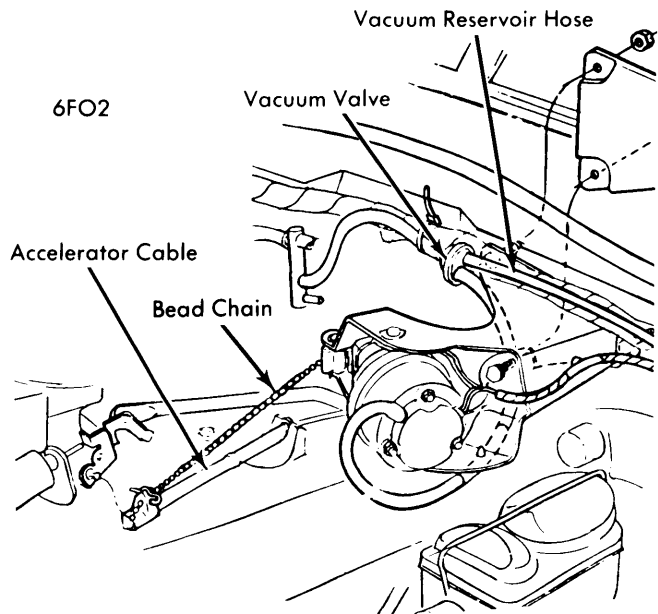

6F02

**SPEED CONTROL SENSOR & SERVO
(TORINO, MONTEGO, ELITE & COUGAR)**

Automatic Speed Controls

FORD MOTOR CO. (Cont.)

ADJUSTMENTS

LINKAGE ADJUSTMENT

Adjust bead chain to obtain .06-.25" actuator arm free travel when engine is at hot idle. On vehicles equipped with solenoid anti-diesel valve, perform this adjustment with ignition switch in "ON" position.

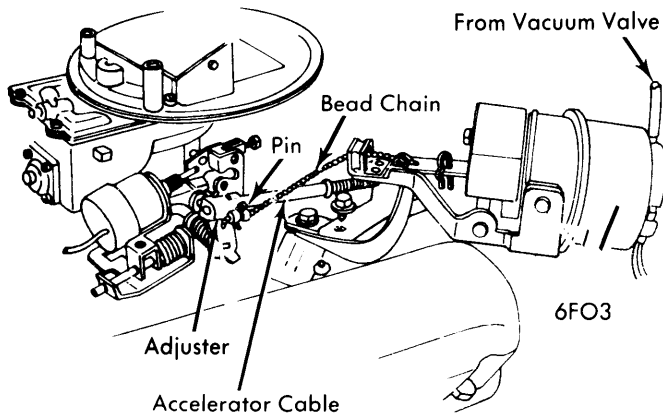

**SPEED CONTROL SENSOR & SERVO
(GRANADA & MONARCH - V8 SHOWN)**

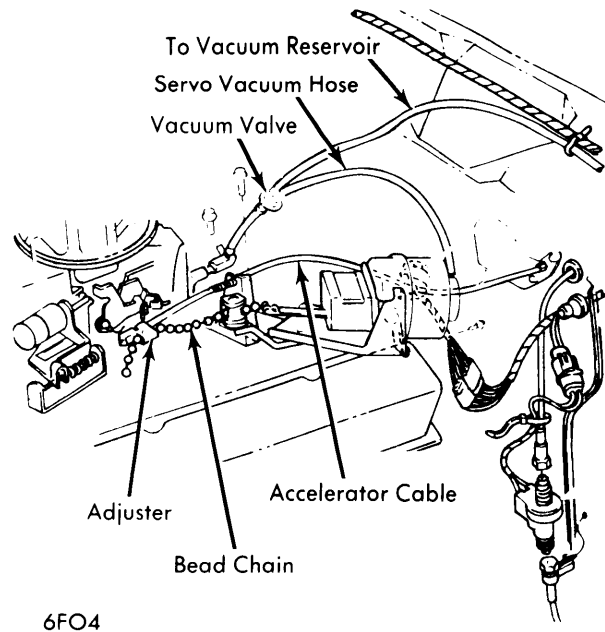

**SPEED CONTROL SENSOR & SERVO
(THUNDERBIRD, LINCOLN, & MARK IV)**