

Windshield Wipers

GENERAL MOTORS – ROUND MOTOR

Buick (Exc. Apollo, Skyhawk)
 Cadillac (All Models)
 Chevrolet (Exc. Camaro, Monza, Nova, Vega)
 Oldsmobile (Exc. Omega, Starfire)
 Pontiac (Exc. Catalina, Bonneville, Grand Ville, Astre, Ventura)

DESCRIPTION

Wiper system consists of a round shaped motor with a depressed park wiper arm feature. Wiper motor field coils are shunt wound for speed control and contains an internal circuit breaker and ground. Motor drive housing contains a reduction gear, pawl to open relay contacts and a terminal board with resistor.

OPERATION

"LO" & "HI" Speeds – With ignition switch on, relay coil circuit is complete to ground through wiper switch. Relay contacts close providing power to motor circuits operating motor in "LO" speed. In "HI" speed, shunt field circuit is grounded through resistor instead of wiper switch (see illustration). On Cadillac, an additional resistor in switch provides a slightly lower than "HI" position resistance when switch is in "MED" position and resistor is paralleled with shunt field circuit resistor.

"OFF" (Park) – Turning wiper switch "OFF" starts motor park cycle. The relay switch circuit is opened allowing the spring-loaded latch arm to move out in path of gear drive pawl. Relay switch contacts, however, remain closed and motor continues to operate until gear pawl engages latch arm. This action unlocks the output shaft and wiper crank arm from gear drive. The output shaft extends through the gear tube off center and as the gear continues to rotate, a cam action results. Gear cam action on output shaft assembly does two things. It causes gear pawl to push relay latch arm into relay housing opening contacts and shutting off wiper motor. Simultaneously, it causes wiper crank arm to move laterally producing additional angular rotation parking wiper arms.

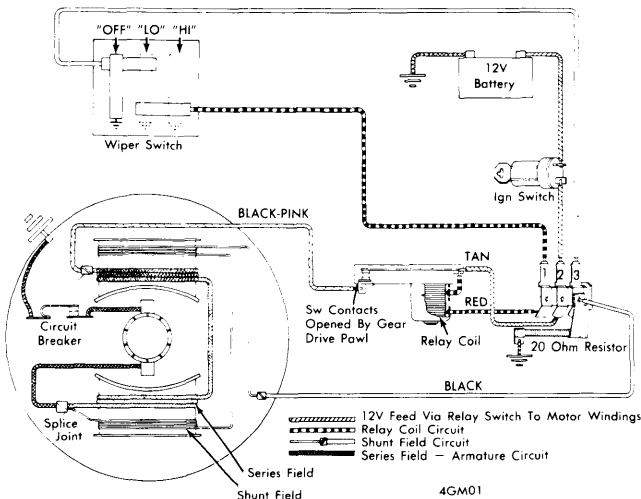

WIPER SYSTEM WIRING DIAGRAM

TESTING

WIPER CIRCUITS (EXC. PULSE SYSTEM)

Preliminary Checks – 1) Check terminal connections and ground on wiper motor and switch. Check fuse. With ignition on, 12 volts should be to center terminal on motor.

2) Disconnect motor connections and operate motor with jumpers by-passing wiper switch. For testing, terminal "1" is adjacent to gear box, terminal "2" is in center and terminal "3" is adjacent to motor housing. Connect power jumper to terminal "2", ground motor and operate with jumpers connected as follows: "LO" speed, connect terminals "1" and "3" to ground. "HI" speed, disconnect terminal "3", terminal "1" remains grounded. "OFF" (Park), reconnect terminal "3" and disconnect terminal "1".

3) If motor operates correctly after by-passing switch and harness, test other system components with motor on car. If motor does not operate, continue to step four.

4) Disconnect wiper linkage from motor crank arm and try jumper wire test again as in step two. If motor operates, check linkage for binds. If motor fails, remove motor and test motor circuits.

Testing System (Motor On Car) – 1) If wiper is inoperative or intermittent, check for an open lead wire from motor terminal "1" to wiper switch. Check for a defective switch or poor switch ground.

2) If wiper will not shut off (blades make full stroke), check for a grounded lead wire from wiper terminal "1" to wiper switch. Check for corroded wiper terminals or defective wiper switch.

3) If wiper will not shut off (blades move up and down about 15° from park), check for an open lead wire from wiper terminal "3" to wiper switch. Check for a defective switch or poor ground.

4) If wiper operates in high speed only, check for open lead wire from wiper terminal "3" to switch, or defective switch.

5) If wiper operates in low speed only, check for a grounded lead from wiper terminal "3" to switch or defective wiper switch.

NOTE – Cadillac only, if wiper operates in high speed with switch in "MED" position, check for open medium speed resistor.

Testing Motor (Off Car) – 1) If wiper is inoperative, check for open relay coil, circuit breaker open, series field open, brushes sticking, defective solder joints or binding condition at relay latch arm.

2) Motor will not shut off (rotates through 360°), check for relay coil grounding, relay latch spring disconnected or broken. Latch arm binding.

3) Motor will not shut off (crank arm moves back and forth with a loud knock), check relay switch contacts shorting together, drive pawl spring disconnected. Motor has open shunt field and operates only in high speed.

4) If motor has only high speed, check for an open shunt field or a poor connection at terminal "3".

5) Motor has low speed only, check for shunt field internally grounded, shunt field lead to terminal board, BLACK wire, grounded or shorted armature.

GENERAL MOTORS – ROUND MOTOR (Cont.)

- 6) If motor has excessive speed in "HI", and "LO" speed is normal, check for an open high speed resistor or poor resistor ground.
- 7) If motor stops at random and does not return to full park, check relay switch contacts. If motor operates intermittently, check for a defective circuit breaker, shorted armature or fields drawing excessive current causing circuit breaker to trip.
- 8) If motor operates normal on bench, but occasionally fails on car, check for proper armature end play, gear assembly end play or poor wire connections.

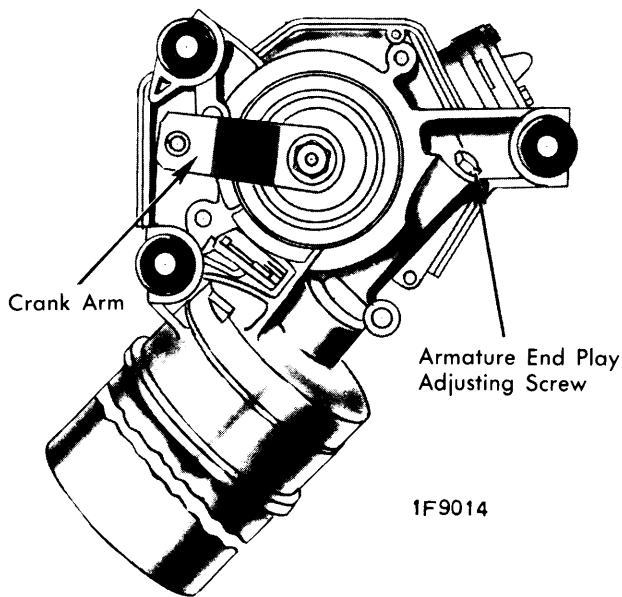

ARMATURE END PLAY ADJUSTMENT

Wiper Motor Armature Adjustment – Loosen adjusting screw lock nut (see illustration) and turn adjusting screw as required until end of screw barely touches end of armature. Back off adjusting screw ¼ turn and tighten lock nut.

WINDSHIELD WASHER SYSTEM

Washer Inoperative – Check washer solution quantity and hoses. Inspect solution screen, hoses and nozzles for plugging. Check electrical connections to washer pump and wiper switch. Test wiper switch and power feed to washer pump. Check pump solenoid or ratchet relay coil. Check ratchet wheel for missing tooth or pawl spring missing. Inspect pump valve assembly.

Washer Pumps Continuously When Wiper Operates – Inspect for a grounded wire from pump solenoid or ratchet relay to switch. Wiper switch may be defective. Check ratchet wheel teeth and dog. Lock-out tang on piston actuator plate may be broken or bent.

REMOVAL & INSTALLATION

WIPER MOTOR

1) Raise hood and remove cowl screen. Loosen transmission drive link-to-crank arm attaching nuts. Remove transmission

drive link(s) from motor crank arm. Disconnect wiring and washer hoses, remove motor attaching screws and remove motor guiding crank arm through opening.

2) To install, reverse removal procedure. Motor must be in "PARK" position when reassembling crank arm-to-transmission drive link(s).

WIPER MOTOR GEARBOX

Relay Switch & Terminal Board – 1) Remove washer pump. If wiper gear drive pawl is in full park position, manually trip latch arm toward coil. Apply feed current to center terminal of relay switch terminal board and ground motor case. Motor will turn gear moving drive pawl out of park position in relay switch slot. If motor does not operate, remove some insulation from the BLACK-PINK wire between motor and relay switch; apply feed current at this point. Tape wire after completing operation.

2) With gear mechanism out of park position, remove relay switch and terminal board attaching screw. Carefully lift assembly from gearbox. Unsolder leads as required. To install assembly, reverse removal procedure.

Drive Gear – 1) Remove washer pump. Clamp crank arm in a vise before removing retaining nut. *CAUTION* – Failure to clamp crank arm in a vise may result in stripping gear. Remove crank arm, rubber seal cap, retaining ring, shim washers, shield and spacer washer. Slide gear assembly out of housing. Slide drive plate and shaft out of gear. Remove drive pawl, lock pawl and coil spring as required.

2) To reassemble drive gear assembly, position drive pawl on drive plate, then install lock pawl. Slide gear and tube over drive shaft allowing lock pawl pins to fit gear guide channels. Reinstall coil spring between lock and drive pawls. Assemble inner spacer washer over gear shaft and install gear assembly in housing. Reassemble outer spacer washer, shield, shim washers, as required to obtain .004" ± .002" end play. Install snap ring and rubber seal cap. Operate motor to park position and install crank arm. Clamp crank arm in a vise before tightening retaining nut. Reinstall washer pump to wiper motor.

MOTOR SPECIFICATIONS

Application	Specification
Operating Voltage	12 Volts
Current Draw (no Load Max.)	
"Lo" Speed	
Camaro, Firebird	5 Amps.
All Other Models	6 Amps.
"Hi" Speed	
Camaro, Firebird	4 Amps.
All Others Models	4.5 Amps.
Current Draw (Stall, Cold)	
"Lo" Speed	
Camaro, Firebird	18 Amps.
All Others Models	29 Amps.