

# Seat Belt Starter Interlock Systems 4-81

## AMERICAN MOTORS

### DESCRIPTION

Seat belt starter interlock system prevents engine cranking unless all front seat belts at occupied positions are fastened after being seated. A seat belt reminder system provides audible and visual indication of an unfastened seat belt. Interlock components are logic module, seat sensors, seat belt buckle switches, starter relay, safety switches and emergency start override switch.

**Seat Sensors** — Send signal to module when seat is occupied. Seat sensors have normally open contacts which close when seat is occupied. Sensor should have continuity when 8 to 40 lbs. weight is on seat cushion.

**Seat Belt Buckle Switch** — Provides signal circuit for module when belt is fastened. Switch is located in female half of buckle in each of front seat belts. Buckle switches have normally open contacts and close when buckled.

### OPERATION

#### INTERLOCK COMPONENTS

**Logic Module** — Monitors sequence of seat sensor and seat belt switch operation. If belts are prefastened before being seated, module will send signal to open starter relay contacts preventing engine crank.

**Warning Buzzer & Light** — Provide audible and visual means of alerting driver when belts are not fastened correctly.

**Starter Relay** — Opens or closes circuit to starter solenoid pull-in winding "S" terminal. Relay contacts are controlled by logic module signals. The ground wire for solenoid pull-in coil is on engine firewall for manual transmission vehicles and on neutral safety switch for automatic transmission vehicles.

**Interlock Component Switches** — Automatic transmission vehicles use a neutral safety switch to prevent engine crank in any forward or reverse gear. Manual transmission vehicles use a park brake switch which provides a means of turning off warning light and buzzer when transmission is in neutral and passenger is unbuckled with ignition "ON".

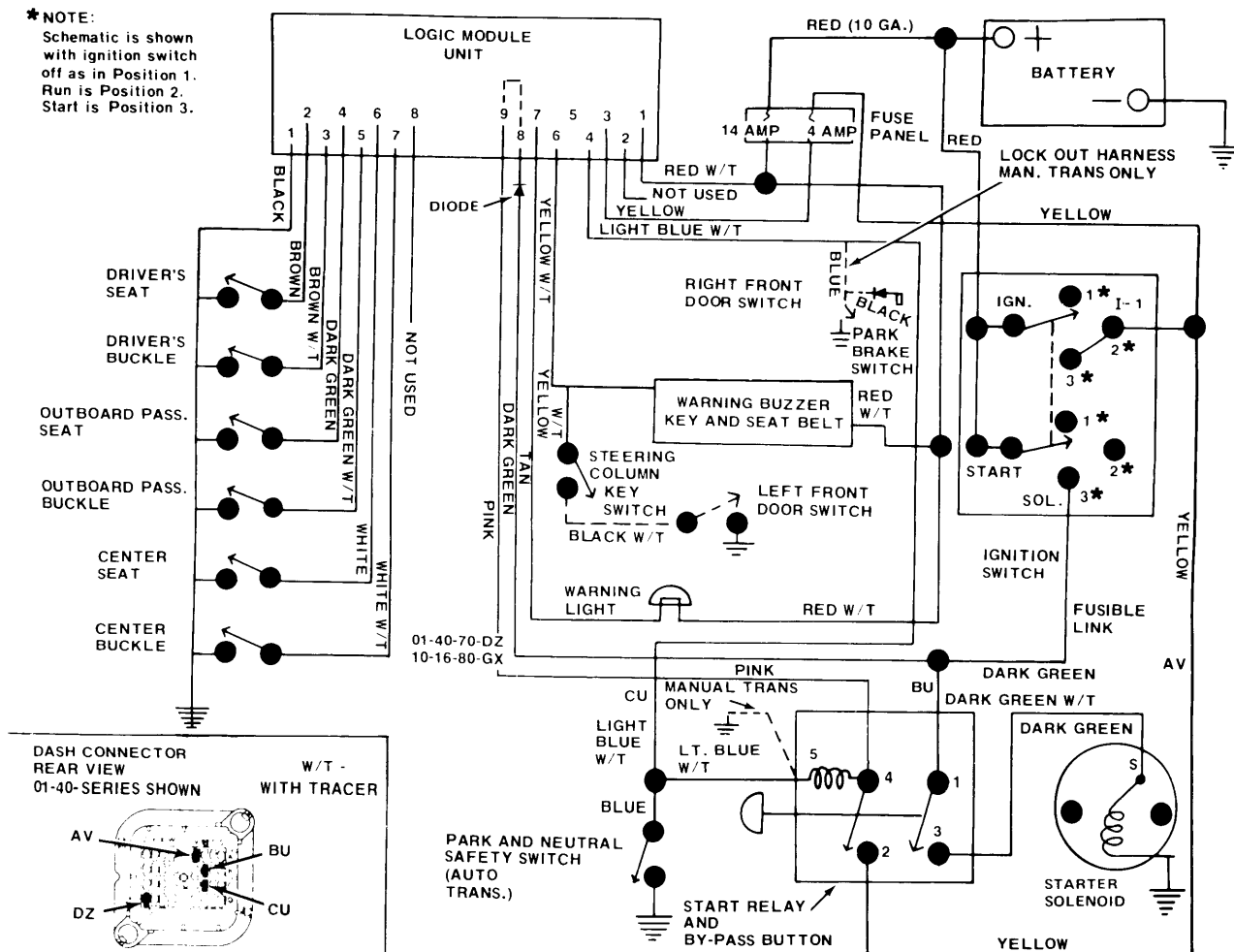

SEAT BELT-STARTER INTERLOCK WIRING DIAGRAM

## AMERICAN MOTORS (Cont.)

**Manual Override Operation** — In event of interlock malfunction, an emergency start override unit is provided and is part of starter relay. To operate, place automatic transmission in "P" and manual transmission in neutral. Apply park brake and turn ignition "ON". Locate relay in engine compartment on right side and depress WHITE button on top of relay. Turn ignition to "START", engine should crank provided malfunction is related to interlock system. Repeat procedure if ignition is turned "OFF" or if automatic transmission is shifted to "D".

**CAUTION** — Anytime an interlock by-pass start or solenoid jump-start is attempted, be certain park brake is applied and automatic transmission is in "P" or manual transmission is in neutral. Do not attempt to energize interlock relay No. 4 terminal with a jumper wire as this could damage a transistor in logic module.

### TESTING

#### NO START — FRONT SEATS UNOCCUPIED

1) Place transmission in "N" or "P" and turn ignition key to "START". Starter should crank, if not, check battery and cables. Buckle seat belts and turn key to "START". Starter cranks: See *Improper Start — Driver Seated & Not Buckled for seat switch tests*. If starter did not crank, turn ignition key to "ON", depress and release starter relay button and turn key to "START". No crank, see step 5). Starter cranks, check voltage of PINK wire to starter relay No. 4 terminal. Turn key to "START". Above 9 volts, replace starter relay. Below 9 volts, see step 2).

2) Connect voltmeter between PINK wire (module terminal No. 9) and ground. Below 9 volts, see step 4). Above 9 volts, check voltage of PINK wire between module (terminal No. 9) and firewall connector. Connect voltmeter between PINK wire at firewall connector (GX), (DZ), and ground. Turn key to "START"; voltmeter indicates below 9 volts, then repair open circuit between module and firewall connector. Above 9 volts, see step 3).

3) Connect voltmeter between PINK wire and ground at engine side of firewall connector; turn key to "START". Above 9 volts, replace PINK wire between firewall connector and starter relay. With less than 9 volts, repair firewall connector at DZ terminal (Hornet, Gremlin) or GX terminal (Matador).

4) Connect voltmeter between DK. GREEN wire (module terminal No. 8) and ground; turn key to "START". Above 9 volts, replace module. Below 9 volts, repair open circuit or diode in GREEN wire between module and fusible link.

5) Starter does not crank. **CAUTION** — Do not replace logic module until PINK and YELLOW wires to starter relay have been checked for short circuits. Depress and hold button in starter relay; turn key to "START". Starter does not crank, see step 6). Starter cranks, check LT. BLUE W/T wire for open circuit by connecting jumper wire between starter relay (No. 5 terminal) and ground; turn key to "START". Starter does not crank, see step 7). Starter cranks, if equipped with manual transmission, repair open circuit between starter relay (No. 5 terminal) and body ground screw. Starter cranks, with automatic transmission, check continuity of LT. BLUE W/T wire between relay (No. 5 terminal) and center terminal of neutral safety switch. No continuity, repair open circuit. With continuity in LT. BLUE wire, check continuity between center terminal and housing of neutral safety switch. Adjust linkage or replace switch as required.

6) Check GREEN wire between starter relay and solenoid; turn key "OFF" and connect voltmeter between battery positive post and No. 3 terminal of starter relay. Solenoid energizes, see step 7). Solenoid does not energize, touch jumper wire to "S" terminal of solenoid. Solenoid energizes, repair GREEN wire between solenoid and relay. Solenoid does not energize, repair solenoid ground, starter motor or cables. Stop test.

7) Solenoid does energize; check YELLOW wire at starter relay, turn key "ON" and connect voltmeter between YELLOW wire at starter relay and ground. Below 9 volts, see step 9). Above 9 volts, check DK. GREEN W/T wire at starter relay No. 1 terminal and ground. Turn key to "START"; above 9 volts, replace starter relay. Below 9 volts, see step 8).

8) Connect voltmeter between DK. GREEN W/T wire BU terminal (engine side of firewall connector) and ground. Above 9 volts, repair open circuit in DK. GREEN W/T wire between relay and firewall connector. Below 9 volts, connect voltmeter between DK. GREEN W/T BU terminal of firewall connector (under instrument panel) and ground. Turn key to "START", above 9 volts, repair firewall connector. Below 9 volts, connect voltmeter between solenoid terminal of ignition switch DK. GREEN wire and ground. Turn key to "START"; below 9 volts, repair ignition switch or battery feed to switch. Above 9 volts, repair open circuit in DK. GREEN wire or replace fusible link.

9) With key "ON", connect voltmeter between YELLOW wire AV terminal (engine side of firewall connector) and ground. Above 9 volts, repair YELLOW wire between firewall connector and relay. Below 9 volts, check same wire on connector under instrument panel, if meter reads battery voltage, repair firewall connector. If not, repair YELLOW wire between ignition switch and firewall connector.

#### NO START — DRIVER SEATED & PROPERLY BUCKLED

1) With automatic transmission, apply park brake and place in "D". With manual transmission, release park brake and place in neutral. With belts fastened, key "ON", wiggle male end of belt buckle, if "FASTEN BELTS" light flickers on and off, replace seat belt buckle assembly. If light does not flicker, place transmission in neutral or "P" and exit vehicle. Turn ignition to "START", starter does not crank, perform "No Start-Front Seats Unoccupied" test and if problem is not located, see step 3). If starter cranks, remove module and check wires for proper location in 8-way connector; if not correct, remove wires and insert in proper location. Continue test.

2) Disconnect module from harness, clean contacts with TV tuner cleaner, check for bent contacts in module or connector. Reconnect module and attempt normal start. Stop test if starter cranks; if not, unbuckle belts and disconnect module from harness. Check for seat belt harness grounds; check continuity between seat belt buckle wires BROWN, DK GREEN, WHITE (W/T) and ground. With continuity, disconnect seat belt wires at seat and retest. A shorted wire will show continuity. With no continuity in seat belt harness, fasten belts, disconnect module and check continuity between BROWN, GREEN, and WHITE wires (W/T) and BLACK wire of connector. If continuity is satisfactory, replace module, if not, repair open circuit in wires tested. Stop test.

3) Disconnect seat sensor switch, starting with driver seat. Turn key to "START" for each seating position. Starter cranks,

## AMERICAN MOTORS (Cont.)

replace seat sensor or repair sensor wire short. Starter does not crank, check seat sensor for short to ground circuit. Remove and disconnect module. Check continuity between ground and seat sensor switch wires. Continuity indicated, repair shorted wire(s); if not, disconnect wire from No. 2 terminal of starter relay and turn key to "START". If starter cranks, repair shorted wire connected to No. 2 terminal; if starter does not crank, replace module.

### BUZZER & "FASTEN BELTS" LIGHT DIAGNOSIS

**Condition A** — Turn ignition "ON", seat belt unbuckled; with automatic transmission, apply park brake and place in "D". With manual transmission, release park brake. If warning light and buzzer operate, system is operating properly, if not, see step 1).

**Condition B** — Seat belt unbuckled and front seat position(s) occupied. With automatic transmission in "P", manual transmission in neutral and park brake applied, turn ignition to "START". If warning light and buzzer operate, system is satisfactory, if not, see step 1). *NOTE* — If light and buzzer do not operate, module may be defective. If only one or the other does not operate, it is unlikely that module is defective.

1) Test module battery feed by disconnecting module from harness. Connect test light between RED W/T wire (9-wire connector) and ground. Test light fails, check 14 ampere fuse. Check RED W/T wire between module and fuse block. Check heavy RED wire (battery feed) to fuse block. Repair as necessary. If test light came on for module battery feed test, check ground wire at module; connect test light between RED W/T wire (9-way connector) and BLACK wire (8-way connector). If test light comes on, see step 2). If light fails, repair ground wire circuit. Ground wire passes through DY of firewall connector (Hornet, Gremlin). Check continuity before entering firewall connector. For Matador, ground wire grounds at left side of instrument panel. *NOTE* — A ground wire can be connected from bullet connector at module to a convenient ground.

2) Check warning light and buzzer ground at module. To test light, connect jumper wire between TAN wire (9-way connector) and ground. To check buzzer, connect jumper wire between YELLOW W/T wire and ground. *CAUTION* — Do not touch YELLOW wire with GROUND wire. If warning light and buzzer operate, replace module; if not, check warning light and buzzer ground at each unit. To check light, connect jumper between TAN wire and ground. To check buzzer, connect jumper between YELLOW W/T wire and ground. If light or buzzer operates now, replace defective wire between unit and module; if not, check battery feed to warning light and buzzer. Connect test light between RED W/T wire at warning light or buzzer and ground. Test light comes on, replace warning light or buzzer. Test light does not come on, check for a defective connection or open circuit between RED W/T wire to warning light or buzzer and fuse block wire.

3) Buzzer and warning light stay on after driver and/or front seat passenger(s) have properly buckled. Determine if a normal start can be achieved; if not, see previous tests. Normal start can be achieved; then disconnect ground wire (BLACK) at bullet connector. Light and/or buzzer stop, replace module. If buzzer continues, repair shorted YELLOW W/T wire between buzzer and module or buzzer and steering column. If warning light remains on, repair shorted TAN wire between light and module.

### IMPROPER START — DRIVER SEATED & NOT BUCKLED

1) Turn ignition to "START" with belts unfastened or prefastened; if starter cranks, check seat switch harness for short circuits. With seat unoccupied, ignition "ON", place automatic transmission in "D" and manual transmission cars, release park brake. If buzzer and warning light do not operate, see step 2). Disconnect seat sensor switch at seat, ignition "ON", weight off seat, transmission in gear and park brake released; if buzzer and light operated, repair shorted wire between seat sensor connector and module. If not, replace seat sensor switch.

2) Test starter relay by disconnecting two-terminal connector from relay (PINK wire and BLUE W/T) wire. Turn ignition to "START", if starter cranks, replace starter relay. If starter does not crank, check seat switch harness for an open circuit. Reconnect two-terminal connector to starter relay and turn ignition "ON". With automatic transmission in "D", or release park brake with manual transmission; sit down or press on seat with at least 35 lbs. of force. If buzzer and light operate, replace module; if not, see step 3).

3) Test seat sensor ground wire. Remove module (do not disconnect from harness). Connect jumper wire from body ground to BLACK wire in module 8-way connector (No. 1 position). Turn ignition "ON", sit or press down on seat positions. If buzzer and light do not operate, see step 4). Buzzer and light operate, repair ground wire. If an improper start can still be achieved, replace module.

4) Test seat sensor switch feed wire for open circuit. Disconnect module from harness connectors. Connect self powered test light between BROWN wire (driver seat) and BLACK wire of 8-way connector or between DK. GREEN wire (passenger seat) and BLACK wire. Sit or push down on seat. If test light shows continuity, replace module. If test show no continuity, disconnect seat sensor switch at seat. Connect self-powered test device across leads of sensor. Sit or push down on seat. With continuity indicated, repair open wire between seat sensor and module; if not, replace seat sensor.

## REMOVAL & INSTALLATION

### INTERLOCK MODULE

**Hornet & Gremlin** — Remove module from brackets. Module is located in right side of glove box.

**Matador** — Remove module from brackets. Module is located on right side of instrument panel next to glove box.

### SEAT SENSOR SWITCH

Two types of seat sensor switches are used. A beam type is used in Hornet and Gremlin models with bench and individual front seats. A pancake type is used in all models with bucket seats and on Matador with bench seats.

**Bucket Seat Sensor** — Disconnect sensor wire below seat, tilt back of seat forward, and remove nylon stops and tilt lock cover. Remove nylon clips attaching seat cover to frame (some use hog rings). *NOTE* — Remove clips by pushing toward center of seat back and twisting downward to disengage from lip of frame. Roll cover back far enough to remove seat sensor switch. To install, reverse removal procedure and note following: When installing a new switch, peel backing paper from switch and install in pad cavity with adhesive side down.

## AMERICAN MOTORS (Cont.)

**Bench Seat Sensor (Matador)** — Remove center seat belt attaching bolts. Disconnect seat sensor and belt buckle switch wires from harness below seat. Remove seat assembly from vehicle with center seat belts. Remove seat cover hog rings from sides and front of cushion and remove seat sensor switch(s). To install, reverse removal procedure.

**Individual & Bench Seat Sensor (Hornet, Gremlin)** — A beam type sensing switch is used between cushion support and seat spring. Disconnect switch at rear of seat, remove seat floor pan attaching bolts and tilt seat toward rear for access to switch. Remove switch retainers from spring and remove switch.

### INTERLOCK & BUZZER DISCONNECT

Disconnecting the interlock and buzzer must be done only at the request of the owner of the vehicle. The "FASTEN SEAT BELT" warning light must remain functional. If the interlock system has a malfunction, correction of the problem is recommended before attempting to disconnect the interlock or buzzer.

### DELETING SEAT BELT WARNING BUZZER

Remove interlock module from attaching bracket for access to 9-way connector. Find YELLOW/BLACK wire on connector and cut out a piece of this wire between connector and wiring harness wrapping. Tape protruding wire ends.

### DELETING INTERLOCK FUNCTION

Remove PINK wire from 2-way connector at emergency start override switch and cut this wire near wiring harness wrap-

ping. Tape protruding wire end. Then remove YELLOW wire from 3-way connector at emergency start switch, and insert it where the pink wire was removed from the 2-way connector. Check for proper operation of warning light. If warning light is burned out or missing, it must be replaced.

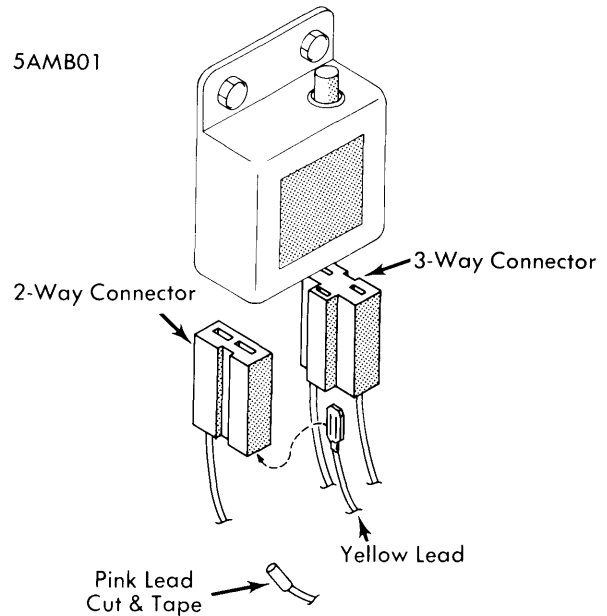

### OVERRIDE SWITCH WIRE RELOCATION