

GENERAL MOTORS

DESCRIPTION

Power seats are operated by a toggle-type control switch on left side of seat or in left door arm rest. Seat adjusters are actuated by a 12 volt reversible motor with a built in circuit breaker. An external 40 ampere plug in type circuit breaker is also used to protect power seat wiring and is mounted on fuse panel. Front seats incorporate a pressure sensitive ignition interlock seatbelt warning system and logic module. During seat service, use extreme care to prevent damage to interlock logic module, wiring and connectors.

OPERATION

2-Way Seats – These seats operate in a horizontal plane in forward or rearward direction only. Seat adjusters are actuated when the control switch energizes the motor. Each end of the motor shaft is connected to a jack screw which propels the seat adjusters in the desired direction through a horizontal gear nut attached to the seat adjuster.

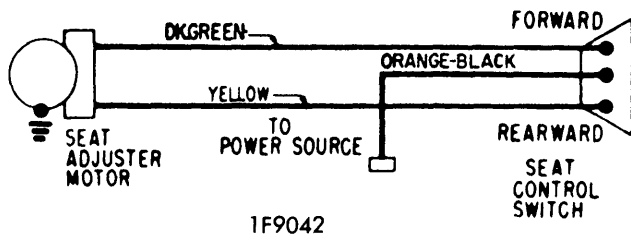

2-WAY POWER SEAT WIRING DIAGRAM

6-Way Seats – Operating mechanism consists of a transmission assembly which incorporates three solenoids and six drive cables to seat adjusters. One solenoid controls front of seat vertical movement, second controls horizontal movement and third controls rear vertical movement. When the control switch is actuated, a double contact first energizes solenoid selected engaging plunger dog and driving gear, then motor is energized. The solenoid driving gear rotates drive cables and operates both seat adjusters moving seat in desired direction.

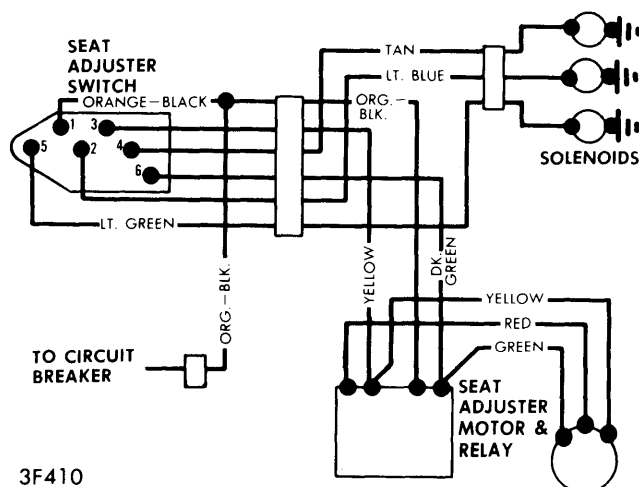

6-WAY POWER SEAT WIRING

COMPONENT REPLACEMENT

SEAT ASSEMBLY

2 & 6-Way (All Body Styles) – Remove seat belt-to-floor pan inner anchor plate attaching bolts. Where necessary, remove door sill plates, and turn back carpet to gain access to adjuster-to-floor pan attaching bolts. Operate seat to full forward and up position. At rear of adjusters remove adjuster-to-floor pan rear attaching nuts. Operate seat to full rearward and full rear tilt position. Remove front adjuster-to-floor pan nuts. Disconnect power seat wire harness under seat. All two door styles have a lap belt warning light and buzzer switch connector under passenger seat. This must also be disconnected prior to removal of seat. Remove seat. To install, reverse removal procedure.

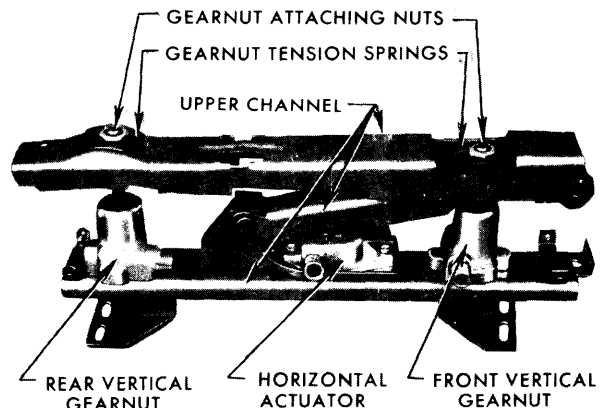

3F408

6-WAY SEAT ADJUSTER MECHANISM

SEAT ADJUSTER ASSEMBLY

2 & 6-Way (All Body Styles) – Remove seat as outlined above. Place seat upside down on bench. Disconnect drive cables at adjuster being removed, squeeze oblong connector to detach. On bucket seats, remove bolt securing motor and transmission support to adjuster being removed. Remove adjuster-to-seat bottom frame front and rear attaching bolts and remove seat adjuster. To install, reverse removal procedure, checking to be sure seats are in "phase".

SEAT ADJUSTER "PHASING"

2 & 6-Way (All Body Styles) – When installing power operated seat adjusters they must be "in phase" with each other. When adjusters are out of phase, one adjuster will reach its maximum travel before the other, resulting in improper travel of seat.

Horizontal Travel – Operate seat until one adjuster reaches full forward position. Detach horizontal drive cable from adjuster which has reached full forward position. Now operate seat forward until other adjuster reaches full forward position. Reconnect drive cable of early adjuster. Adjusters are now in phase.

Vertical Travel (Front or Rear) – Operate seat until one adjuster has reached fully raised position at both front and rear vertical travel limits. Disconnect both front and rear vertical drive cables from adjuster which has reached fully raised position.

GENERAL MOTORS (Cont.)

tion. Operate seat until other adjuster reaches fully raised position. Now reconnect cables of early adjuster. Seat should now be in phase, if not repeat the above procedure.

DRIVE MOTOR

2-Way Seat – If seat is operable, operate seat to a midway position. Remove front seat adjuster-to-floor pan attaching bolts and tilt seat rearward. Remove power drive cables from motor. Disconnect motor wiring. Remove screws that secure motor support bracket to seat bottom frame and remove motor with bracket attached. Disassemble motor and bracket as a bench operation. To install, reverse removal procedure.

6-Way Seat – Remove front seat assembly as previously described. Place seat on bench upside down. Disconnect motor feed wires from motor control relay. Remove motor and transmission support-to-seat frame attaching bolts. Now remove motor-to-support screws, then move motor assembly outboard away from transmission to disengage motor from rubber coupling. To install, reverse removal procedure.

ADJUSTING

Horizontal Actuator Adjustment – Chucking can be corrected by adjusting the horizontal actuator and pinion gear to full mesh with the lower adjuster lower track rack-gear as follows:

Operate seat to full up position, and approximately a 3/4 full forward position. Loosen horizontal actuator screws.

Using a large screw driver as shown in illustration, apply outward pressure on horizontal actuator (about 15-25 lbs.) and at the same time energize horizontal switch to move seat fore and aft slightly. This helps seat the horizontal actuator pinion gear teeth tight to the lower track rack gear teeth and eliminate free play between gear teeth. While maintaining outward pressure against horizontal actuator, tighten actuator screws.

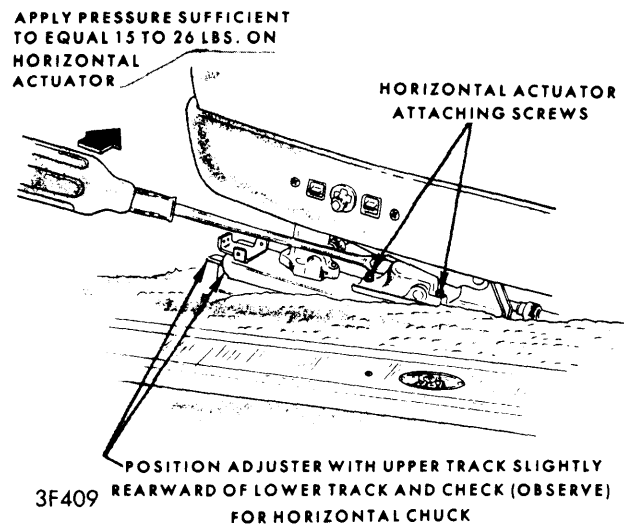

HORIZONTAL ACTUATOR ADJUSTMENT TROUBLE SHOOTING

Jerky Horizontal Operation – Improper lubrication of adjuster shoes and channels. Adjuster shoes too tight in upper channels.

Horizontal Chuck or Looseness – Horizontal actuator improperly adjusted.

One Adjuster Will Not Operate Horizontally – Horizontal drive cable damaged or disconnected. Horizontal actuator inoperative.

One Adjuster Will Not Operate Vertically – Vertical drive cable disconnected or damaged. Vertical gear nut inoperative.

Both Adjusters Will Not Operate Horizontally or Vertically – Inoperative horizontal or vertical solenoid in transmission.

Vertical Chuck or Looseness – Excessive clearance at vertical gear nut tension spring.