

CHRYSLER CORP. ELECTRIC

DESCRIPTION

All doors can be locked or unlocked electrically by operating either of the front door locking buttons. Right front and both rear doors can be locked or unlocked mechanically with inside door lock buttons. Driver's door can be unlocked, but not locked, mechanically from inside door except on Chrysler New Yorker Brougham and Imperial. They can be locked mechanically from inside front left door locking console lever. The tailgate door locks automatically when ignition switch is turned "ON". It may be unlocked when ignition is "ON" by pressing and holding spring loaded unlock switch while opening tailgate. Locks are operated by a push-pull double action solenoid. Solenoid is attached by a connecting rod-to-door lock actuating lever located in each door. A single pole double throw switch is mounted on each front door and a console mounted toggle switch which controls system. Trunk lid lock consists of a push button switch and a solenoid. Solenoid is energized only when button is depressed

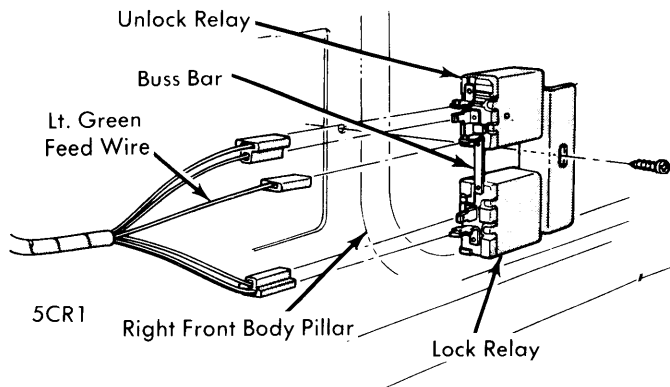

DOOR LOCK RELAYS

ELECTRICAL TESTING

DOOR LOCK SYSTEM

Before making tests, battery must be fully charged and solenoids correctly adjusted. Circuit breaker is located on fuse block, and door lock relay is located behind right side cowl kick panel. Connect positive lead of voltmeter to buss bar on relay, negative lead to a good ground. With no load, voltage should read 12.5 volts; with a load (locks activated), voltage should be 11 volts. If no reading is obtained, circuit breaker should be tested. Connect a voltmeter positive lead to light green terminal of circuit breaker and other lead to a good ground. If a reading of 12.5 volts is not obtained, connect voltmeter to battery side of circuit breaker. If a reading is obtained, circuit breaker is probably defective and should be replaced. If no reading is obtained, inspect for a broken feed wire or loose connection. Check each individual door lock solenoid by disconnecting solenoid connectors. If a solenoid has been shorted, excess current may have damaged door lock relays.

TAILGATE LOCK SYSTEM

Battery must be fully charged and solenoid properly adjusted. Remove wiring connector at tailgate solenoid. Connect a test light to Pink lead (Fury & Coronet) or Orange lead (Gran Fury, Monaco & Chrysler) at connector in wiring harness. With ignition switch "ON", test light should light. Move tailgate unlock switch to unlock position and hold, light should go out. Move test light to Orange lead (Fury & Coronet) or Pink lead (Gran Fury, Monaco & Chrysler) in connector, test light should

go out. Actuate tailgate unlock switch and test light should light. To determine if solenoid is operating properly, connect a hot lead to Orange wire in solenoid connector, solenoid link should extend. Move hot lead to Pink wire and solenoid should retract.

TRUNK LID LOCK RELEASE

Battery must be fully charged and latch and striker adjusted so trunk lid latches with a moderate slam. With ignition switch in "ON" or "ACCESSORY" position, push trunk lid unlock switch and lid should unlock. Trunk lid unlock switch is located on instrument panel or in glove box depending on model variation. If lid latch fails to unlock, check solenoid lead wire and connection. A minimum of 10 volts is required at solenoid. Check for proper ground. With solenoid removed, check plunger spring and attachment. Solenoid travel is adequate with $\frac{3}{8}$ " movement.

SOLENOID ADJUSTMENT

DOORS

Loosen solenoid mounting screws and slide solenoid to full down position. Extend solenoid link until latch is in locked position. Tighten solenoid mounting screws and test operation of lock.

TAILGATE

Fury & Coronet — Latch both tailgate upper latches. Push control button to locked position. Loosen solenoid mounting screws. Push solenoid toward locking control assembly. Holding solenoid, push locking control push rod until it bottoms out in locked position. Holding solenoid in this position, tighten mounting screws.

Gran Fury, Monaco & Chrysler — With tailgate latches correctly adjusted, loosen screw at locking control swivel to allow solenoid shaft rod-to-locking lever to float in swivel. Push lock control knob and rod to locked position. Pull solenoid locking lever toward tailgate (away from solenoid body) and tighten screw.

TRUNK LID

Latch and striker must be correctly adjusted before adjusting solenoid. When adjusting latch, use caution not to create too much tension on latch, or solenoid will be unable to release latch. To adjust solenoid, loosen solenoid mounting screws and move solenoid toward or away from latch assembly to adjust.

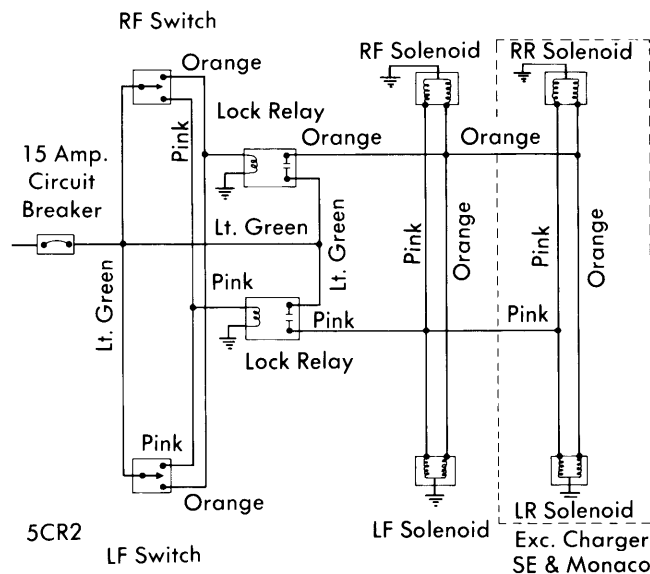

DOOR LOCK WIRING SCHEMATIC