

## FORD MOTOR CO. HEATED REAR WINDOW

### DESCRIPTION

System incorporates a series of grid wires baked on inside surface of rear window. Grid wires are heated by current from control switch relay.

### OPERATION

System is controlled by a three-position switch which is spring loaded to return from "ON" or "OFF" to its center or "NORM" position. When switch is turned to "ON", a relay is energized and delivers current to grid wires in rear glass. Relay is called a latching relay because it remains latched in energized position until either control switch or ignition switch is turned off.

### TESTING

**Control Switch** — With switch in "NORM" position, continuity should exist between two terminals. In "ON" position, there should be continuity between all terminals. In "OFF" position, there should be no continuity.

**Latching Relay** — Ground relay case and connect a jumper wire between pins one and two. Connect a 12 volt test light between pin three and ground. Apply voltage to pin two. Test light should not light. Momentarily short pin two and pin five test light should come on and stay on after short is removed.

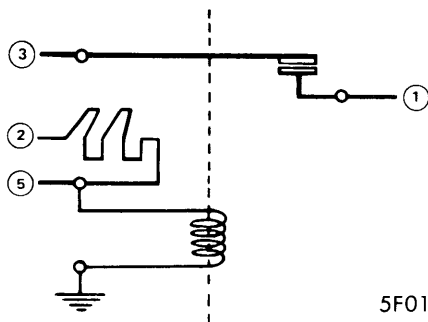

LATCHING RELAY TEST CIRCUIT

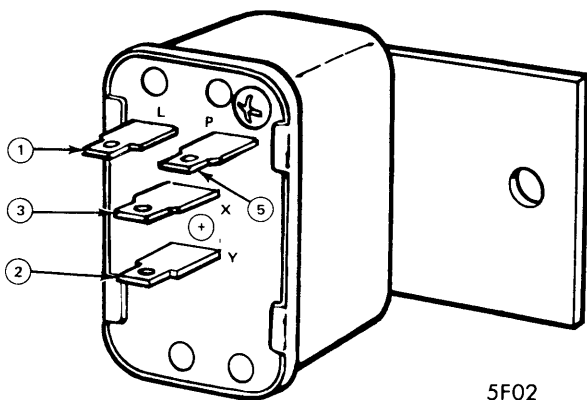

LATCHING RELAY

**Relay Location** — On Ford and Mercury, relay is located under lower edge of instrument panel on left side. On Cougar, Torino, Elite and Montego, relay is mounted on instrument panel above headlight switch. On Pinto and Bobcat, relay is mounted on instrument panel above glove box. On Mustang, relay is mounted on a brace between steering column "Y" brace and left cowl side panel under instrument panel. On Thunderbird and Mark IV, relay is mounted on a brace under instrument panel and next to brake pedal support bracket. On Continental, relay is mounted under instrument panel. On Granada and Monarch, relay is mounted to right cowl side panel inside access hole.

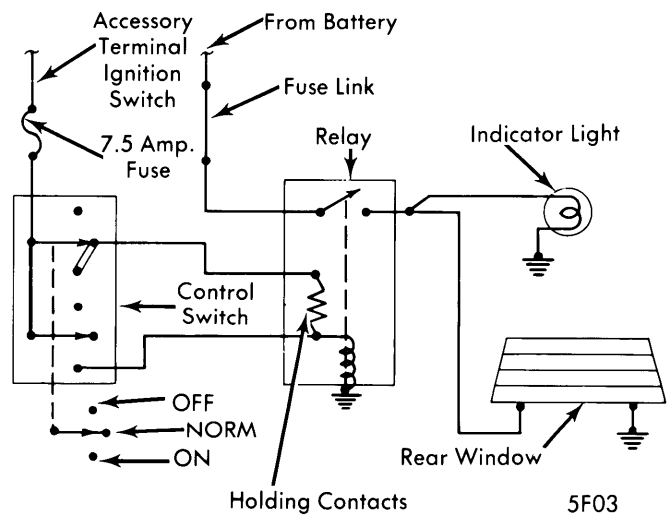

HEATED REAR WINDOW CIRCUIT (EXC. BOBCAT, MUSTANG, PINTO, GRANADA & MONARCH)

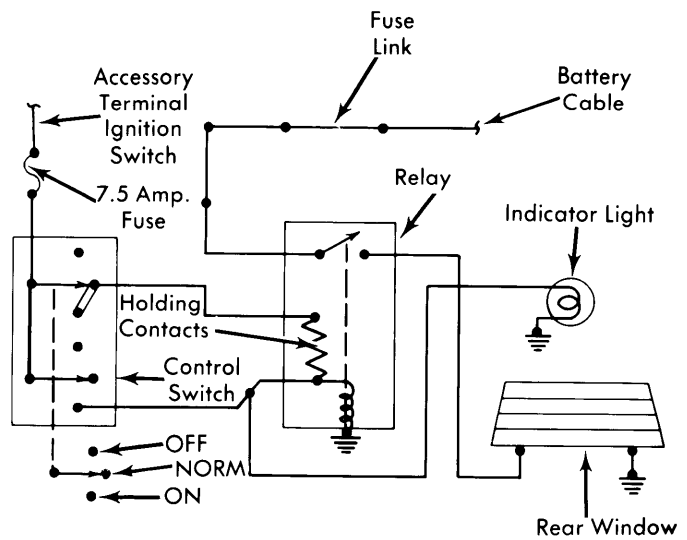

HEATED REAR WINDOW CIRCUIT (MUSTANG, PINTO, BOBCAT, GRANADA & MONARCH)