

## CHRYSLER CORP. SAFEGUARD SENTINEL

Chrysler  
Imperial

## DESCRIPTION

This unit is an electronic device which automatically controls on-off operation of headlights, tail lights and instrument panel lights. System consists of a light sensitive photocell on top of instrument panel, an amplifier unit, a variable time-delay switch, and a master control switch. During automatic operation, system is protected by a circuit breaker in amplifier. During manual operation, system is protected by headlight switch circuit breaker.

## OPERATION

## AUTOMATIC

1) With time-delay control switch "ON", ignition switch "ON", and regular headlight switch "OFF", photocell is responsive to amount of daylight and will automatically turn lights on when daylight decreases to point where lights are required for safe driving. Driver adjustment of time when lights turn on is provided by rotating cap on top of photocell between "EARLY" and "LATE" positions. **CAUTION** — Do not rotate cap so far that light through window in cap is blocked off from cell. Circuit is designed so lights will not go on or off with sudden changes in lighting such as passing under bright lights or going through tunnels.

2) A variable time-delay control switch permits driver to select a delay period from one to three minutes for lights to go off after ignition switch is turned off. Additional lighting at rear of car is provided by the unit turning on back-up lights when headlight switch is turned on and ignition switch is off (lights go off when ignition switch turned on). When ignition switch is turned off, all lights will go off automatically at end of time-delay period selected by driver.

## MANUAL

For manual operation, operate regular headlight switch in normal manner, with time-delay control switch turned off. **NOTE** — Malfunction in Safeguard Sentinel circuit will not interfere with manual operation if time-delay control switch is off.

## TESTING

## PRELIMINARY CHECKS

Make sure time-delay control switch is not in "OFF" position. Make sure photocell is not obstructed. Standard headlight switch must be "OFF". Lighting system should operate correctly manually. Ensure that fuses are not blown. **CAUTION** — Time-delay control switch acts as a ground for entire system. If system does not perform properly, connect jumper wire from switch knob to good ground on body. If system now operates properly, remove switch bezel and clean paint from panel so good contact will be made when bezel is installed.

## PHOTOCELL

1) Cover photocell with black cloth, start engine, and turn on system. If lights fail to come on within a few seconds, uncouple multiple connector at amplifier, remove gray wire from connector to body wiring and recouple connector. If lights come on, replace photocell and reinstall gray wire.

2) If lights fail to turn off automatically with adequate outside lighting, shine a bright light into photocell window and rotate cap to centered position between "EARLY" and "LATE". If lights turn off, cap may have been rotated so far that light through window in cap was blocked off. If lights remain on, check photocell by connecting jumper wire from gray wire to black wire at amplifier to close photocell circuit. If lights now turn off, replace photocell.

## TIME-DELAY CONTROL SWITCH

1) Check switch for good ground. If photocell tests good, and lights do not turn off automatically after ignition is turned off, connect jumper wire between yellow wire and light green wire at switch. If lights now turn off, replace switch.

2) If lights turn off immediately after ignition is turned off (no time delay), check tail light fuse and check switch for short.

## AMPLIFIER

1) If lights do not turn on automatically, and photocell and switch tests are good, remove amplifier from heater plenum chamber flange and disconnect multiple connector. Connect jumper wire from red wire to light blue wire in connector on body wiring side. If lights now turn on, replace amplifier.

2) If lights do not turn off automatically, and photocell and switch tests are good, disconnect multiple connector at amplifier. If lights now go off, replace amplifier.

3) If lights fail to turn off automatically when ignition is turned off, or lights turn off immediately regardless of time control setting on switch, check system with amplifier known to be good. If lights operate properly, replace original amplifier.

## TROUBLE SHOOTING

## LIGHTS DO NOT GO ON AUTOMATICALLY

Loose connections, poorly grounded time control switch, faulty time control switch, faulty photocell or amplifier.

## LIGHTS DO NOT TURN OFF AUTOMATICALLY

Photocell covered by clutter on instrument panel, loose connections in photocell or faulty photocell, faulty amplifier.

## LIGHTS TURN OFF IMMEDIATELY WHEN IGNITION IS TURNED OFF

Tail light fuse blown, faulty time control switch, short circuit between yellow wire and light green wire at time control switch or faulty switch, faulty amplifier.

## CHRYSLER CORP. SAFEGUARD SENTINEL (Cont.)

### LIGHTS STAY ON TOO LONG AFTER IGNITION IS TURNED OFF

Loose connection in yellow wire or light green wire of time control switch, faulty switch or amplifier.

### BACK-UP LIGHTS DO NOT LIGHT

Loose connections, defective circuit breaker on windshield wiper, faulty amplifier.

### BACK-UP LIGHTS OPERATE MANUALLY BUT NOT DURING TIME DELAY PERIOD

Faulty amplifier.

## REMOVAL & INSTALLATION

### TIME-DELAY CONTROL SWITCH

See *Switches, Gauges, Speedometer in A & E SECTION* for removal of instrument cluster bezel. After instrument cluster bezel has been removed, rotate switch knob until screw is visible, loosen setscrew and remove knob. Remove bezel nut and remove switch. To install, reverse removal procedure.

### PHOTOCELL

Disconnect fusible link in engine compartment and remove cowl top cover. Disconnect black and gray wires at photocell connector and remove Tinnerman clip. Remove photocell by lifting up through mounting hole. Cut wires and remove unit. To install, reverse removal procedure.

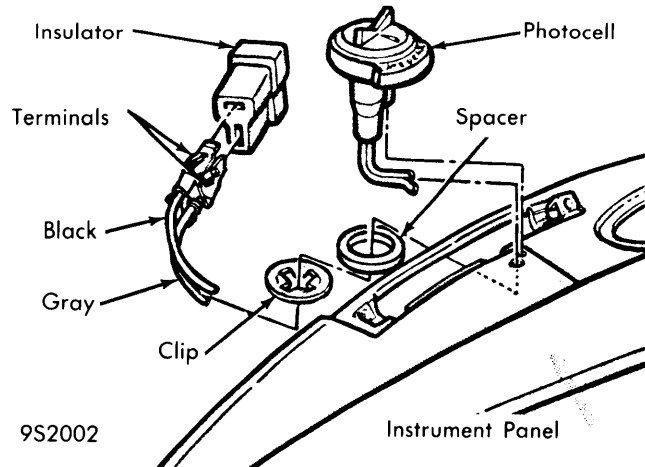

SAFEGUARD SENTINEL PHOTOCELL ASSEMBLY

### AMPLIFIER

Disconnect fusible link and remove lower instrument panel. Disconnect multiple connector and remove two attaching screws from lower instrument panel reinforcement. Remove amplifier. To install, reverse removal procedure.

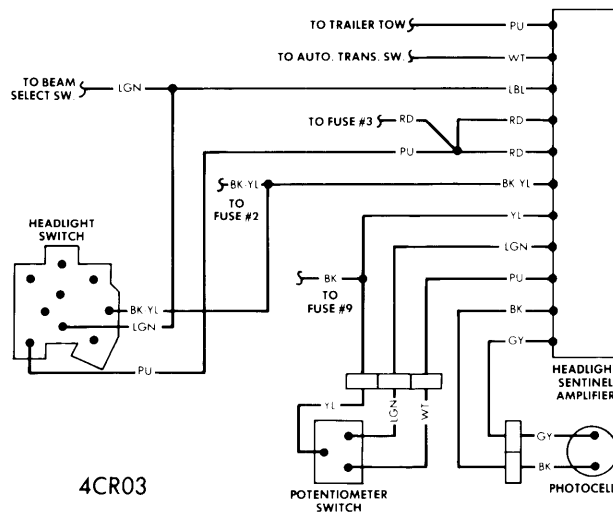

SAFEGUARD SENTINEL WIRING DIAGRAM