

Power Windows

FORD MOTOR CO. TAILGATE

DESCRIPTION

Electrically controlled station wagon tailgate window is operated by a reversible electric motor and a window regulator mechanism in tailgate. Control is through a key operated lock switch on upper right of tailgate outer panel, and a toggle or push-pull switch on left front door or instrument panel for driver control. A limit switch located at right side of tailgate pillar post prevents operation of window when tailgate is open.

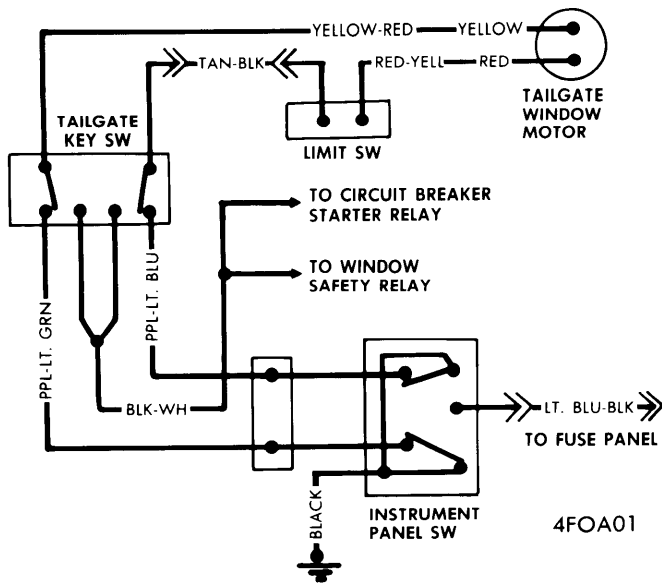

FORD MOTOR CO. POWER TAILGATE WINDOW WIRING DIAGRAM

TESTING

WINDOW MOTOR

Connect a fully charged 12 volt battery to window motor with an ammeter connected in series. Current draw for this no load test should not exceed 5 amps., and should not fluctuate. Reversal of the electrical connections should reverse motor rotation. Replace motor if current draw exceeds specifications. With motor installed, current should be about 12 amps. With window against a stop, current draw should be about 20 amps.

REMOVAL & INSTALLATION

REGULATOR & MOTOR ASSEMBLY

Torino, Montego – Remove tailgate trim cover and watershield. Remove inner access cover. Lower tailgate, and partially raise glass. Remove screws attaching each side of glass to bracket, and remove bushings and stops. Remove glass. Disconnect motor wires. Remove regulator attaching screws and disengage regulator from mounting brackets. Slide regulator to one side to disengage regulator arm rollers from glass brackets. Remove regulator.

Ford, Mercury, Meteor – Remove tailgate trim cover and watershield. Remove upper stops from glass. Remove right and left guides from glass. Remove regulator arm brackets from glass. Disconnect wires from rear window defroster terminals, if so equipped. Remove glass. Remove regulator arm brackets from rollers. Disconnect motor wires. Remove regulator attaching screws, and remove regulator.

MOTOR REMOVAL FROM REGULATOR

To remove motor from regulator, mount assembly in a vise. Drill a $\frac{5}{16}$ " hole through sector gear and regulator plate. Install a $\frac{1}{4}$ " bolt in hole to keep gear from moving when motor is removed. This must be done to prevent personal injury.

MOTOR REMOVAL (WITHOUT REMOVING REGULATOR)

All Models – Remove tailgate inner panel and watershield. Disconnect motor wires at connector. Working through access holes, remove three motor and drive-to-regulator attaching screws. Remove motor and drive from tailgate.

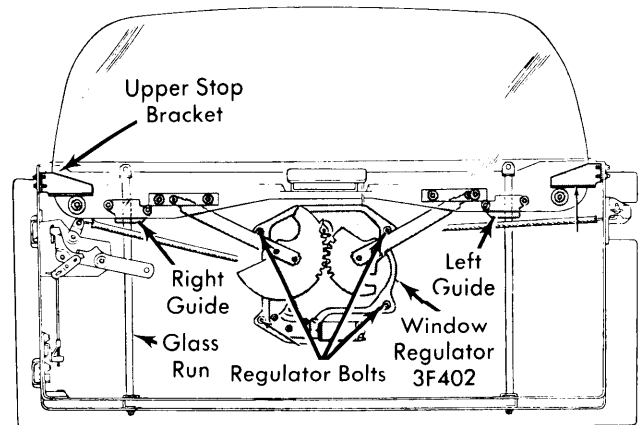

TAILGATE MECHANISM – FORD, MERCURY, METEOR

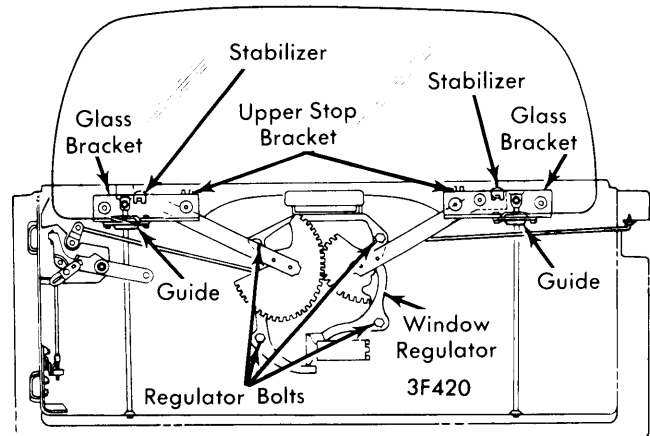

TAILGATE MECHANISM TORINO, MONTEGO