

CHRYSLER CORP.

DESCRIPTION

Electric window lift motors for front, rear and quarter panel windows are permanent magnet type. Motors are grounded through the master switch by a black lead attached to the left cowl panel.

TESTING

NOTE — Check inoperative glass for a binding condition between glass and run channels. Correct binding before making electrical tests.

SWITCH VOLTAGE

Remove switch from trim panel and carefully disconnect multiple terminal block on wire harness from switch body. Using a suitable test lamp, connect one lead of test lamp to black wire terminal and other test lamp lead to tan wire terminal. If light comes on, power circuit from battery is good. If light does not come on, check 30 amp. power fuse or for broken or shorted wire in circuit.

SWITCH "UP" TEST

1) Using two jumper wires, connect one jumper wire end to tan wire terminal and other end of jumper wire to UP terminal (see illustration). Connect other jumper wire to DOWN terminal and ground (see illustration).

2) If motor runs, power circuit to motor or switch is good. Reinstall switch to multiple connector and actuate switch. If motor does not run, replace switch body. If motor still does not run with switch replaced, perform Motor Lift Test. Test each window switch using same procedure.

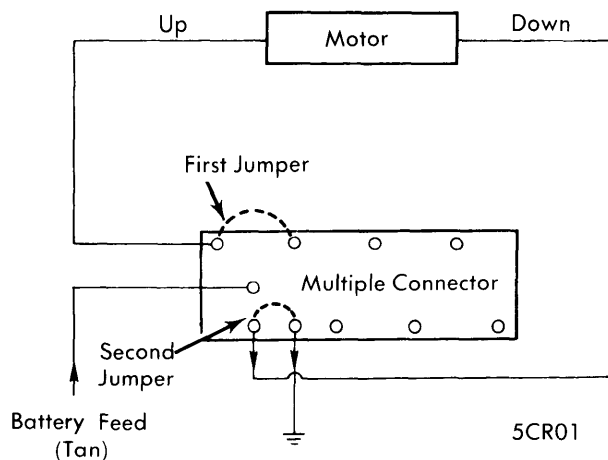

SWITCH "UP" TEST CIRCUIT

SWITCH "DOWN" TEST

1) Using two jumper wires, connect one jumper wire end to tan wire terminal and other end of jumper wire to DOWN terminal (see illustration). Connect other jumper wire to UP terminal and ground (see illustration).

2) If motor runs, power circuit to motor or switch is good. Reinstall switch to multiple connector and actuate switch. If motor does not run, replace switch body. If motor still does not run with switch replaced, perform Motor Lift Test. Test each window switch using same procedure.

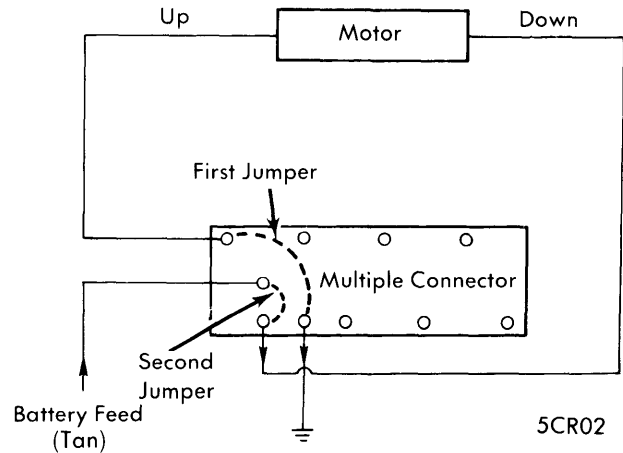

SWITCH "DOWN" TEST CIRCUIT

MOTOR LIFT TEST

1) Check motor by connecting a test battery positive lead to either of the motor terminals. Connect the negative lead of test battery to the opposite motor lead. Motor should operate to move window up or down.

2) Reverse the test battery leads. The motor should operate in opposite direction. If not, replace motor.

REMOVAL & INSTALLATION

DOOR WINDOW REGULATOR & MOTOR

1) Remove door trim for access to regulator. Remove regulator fasteners which disengage the regulator drive arm, and cross arms from connecting lift channel, and pivot bracket. If necessary, remove fasteners holding lift channel and pivot bracket. Disconnect motor wire harness.

2) If possible, electrically activate regulator motor to full up position to relieve counter balance spring tension. **CAUTION** — To avoid injury, do not remove counter balance spring or motor from regulator without locking regulator in a bench vise. With counter balance spring removed, remove motor from regulator.

3) To install regulator assembly and counter balance spring, proceed as follows: Position sector and plate in window up position. Clamp with a vise and install counter balance spring. Remove regulator from vise and operate motor to window down position to check counter balance spring wind-up. Install regulator in door while in half down position. Engage regulator drive and cross arms to lift channel and pivot bracket. Align window run channels as required to provide proper sealing.

CHRYSLER CORP. (Cont.)

MOTOR REMOVAL W/O REGULATOR (CHRYSLER, IMPERIAL, MONACO & GRAN FURY, REAR DOORS ONLY)

NOTE — Following procedure is not recommended if any system parts are loosened or removed from door. If window system parts other than motor are to be removed, use procedure for Removing Door Window Regulator and Motor.

1) With door trim panel removed, raise window to full up position, support window up with a block while removing and replacing motor. Disconnect motor wiring connector, remove screws holding motor gearbox to regulator and bracket support.

2) To remove motor, grip motor housing and pull towards outer panel, rocking action may be necessary to disengage motor from regulator. **CAUTION** — Keep hands and fingers away from sector gear area to avoid pinching by regulator linkage movement.

3) To install, reverse removal procedure and note following: When installing motor, position motor gearbox to engage regulator sector teeth and center post on gearbox must fit into pilot hole in plate.

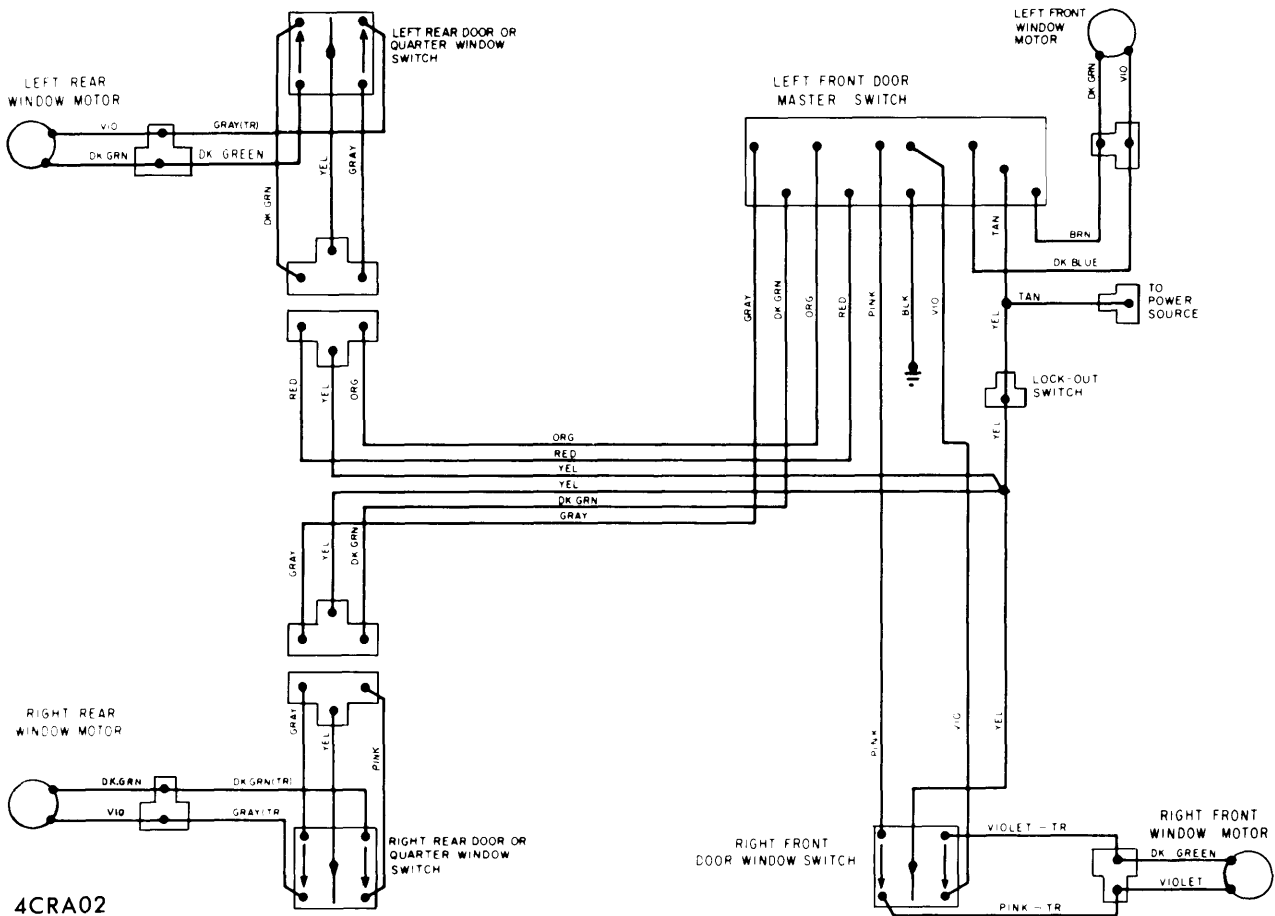

**POWER WINDOW WIRING DIAGRAM
CHRYSLER, IMPERIAL, MONACO & GRAN FURY SHOWN, OTHERS SIMILAR**