

AMERICAN MOTORS TAILGATE

DESCRIPTION

The window motor is of a two wire design, using polarity of circuit to change motor rotation. Window is controlled by two switches. One switch is mounted in instrument panel while the other switch is mounted in tailgate key lock. A safety catch, incorporated in tailgate, prevents tailgate from being opened until window is fully lowered. Ignition switch must be in "ON" or "RUN" position for switch on instrument panel to operate window, switch in tailgate key lock operates window at all times. Two 20 amp. circuit breakers, mounted in back of instrument panel on far left side, protects circuit.

TROUBLE SHOOTING

WINDOW FAILS TO OPERATE OR OPERATES SLOWLY

Battery low or dead. Defective circuit breaker. Loose battery ground. Loose or corroded terminals in control circuit.

WINDOW OPERATES INTERMITTENTLY

Loose wires on circuit breakers or switches. Defective circuit breaker.

TESTING

MOTOR (BENCH TEST)

With motor removed, connect a 12 volt power source to motor leads. Motor should operate. Reverse power source on leads, motor should operate in opposite direction. If motor fails to operate, check for binding in regulator. If regulator is free, motor or electrical leads to motor are defective.

REMOVAL & INSTALLATION

TAILGATE WINDOW REGULATOR

Replacement — Remove tailgate remote control handles and trim panel. Open tailgate and raise glass to the full up position. To raise glass while tailgate is open, manually depress safety switch. Slide glass out of slide channels to remove. Now remove two access hole covers. Move regulator arms to a horizontal position. Disconnect motor wiring from harness. Mark regulator position for installation. Remove four regulator mounting bolts. Remove regulator through access opening. To install, reverse removal procedure.

MOTOR & DRIVE UNIT

CAUTION — Regulator arms and sector gear are under counterbalance spring tension. Secure sector gear to back plate with a bolt before removing motor and drive.

Replacement — Remove window regulator. To retain spring tension, drill a 1/4" hole in back plate under one of the existing holes in sector gear. Insert bolt and secure with a nut. Remove nuts attaching motor to drive unit and separate motor from drive. Insert a screwdriver blade into coupling and turn until spring tension on drive unit is relieved. Remove bolts securing drive unit to regulator. To install, reverse removal procedure.

TAILGATE EMERGENCY OPENING

Disconnect battery. Remove remote control handles, trim panel, and access hole covers. Remove screws retaining regulator arm slide channels to glass bottom channel, hold glass in place and force slide channel out of glass bottom channel retaining brackets. Then lower window into tailgate. Repair malfunction.

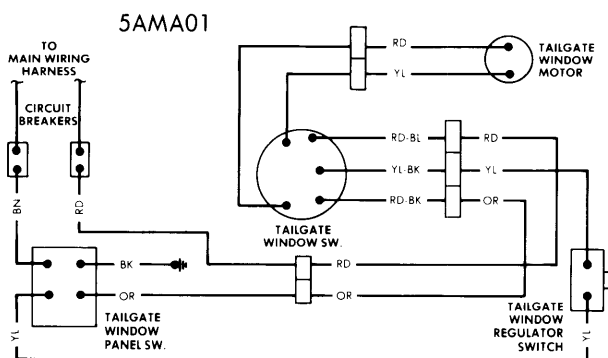

POWER TAILGATE WINDOW WIRING DIAGRAM