

AMERICAN MOTORS

DESCRIPTION

Window motors are of a two wire design, using polarity of circuit to change motor rotation. Windows are controlled by an individual switch mounted in each door trim panel. A complete set of switches controlling all windows is mounted in driver's door. A lockout switch, also mounted in driver's door, allows driver only to operate all windows in vehicle. The ignition switch must be in "ON" or "RUN" position to operate windows. A 20 amp. circuit breaker, mounted in back of instrument panel on far left side, protects circuit. Sedan models are equipped with one circuit breaker while station wagon models with power tailgate window option are equipped with three circuit breakers.

TROUBLE SHOOTING

WINDOWS FAIL TO OPERATE OR OPERATE SLOWLY

Battery low or dead, circuit breaker faulty, battery ground loose, terminal in control circuit loose or corroded.

WINDOWS OPERATE INTERMITTENTLY

Loose wires on circuit breaker or switches, or circuit breaker faulty.

ONE WINDOW FAILS TO OPERATE

Loose or broken connections at circuit breaker, faulty switch, defective window motor.

TESTING

CONTROL & SAFETY SWITCHES

1) Remove safety switch escutcheon and housing. Release barbed retainer hooks separating terminal plate halves to expose wire terminal ends. Turn ignition switch to "ON" position.

2) Using a 12 volt test lamp, connect one lamp lead to a black wire and other end to blue wire (without tracer). Repeat procedure with other black wire at master switch.

3) If lamp does not light, connect lamp lead that was on black wire to a good ground. If lamp now lights, an open circuit between switch and ground on dash exists.

4) If bulb still does not light, it indicates a defective circuit breaker or open circuit in blue wire between circuit breaker and master switch.

CIRCUIT BREAKER

1) Disconnect yellow wire from circuit breaker. Connect a test lamp between yellow wire and chassis ground. Turn ignition switch to "ON" position. If lamp does not light, an open circuit exists in yellow wire or ignition switch is defective.

2) Reconnect yellow wire to circuit breaker and disconnect blue wire from circuit breaker. Connect a test lamp between blue wire and ground. If lamp lights with ignition switch "ON", circuit breaker is good, if lamp does not light, circuit breaker is defective.

CONTROL SWITCH & MOTOR

NOTE — Before checking individual door controls, make sure safety switch is in the "ON" position.

1) Connect a test lamp between green and white wires on master switch. Operate switch up and down at respective window. If test lamp lights in both "UP" and "DOWN" positions, green and white wire circuit between master switch and that window is good. It also indicates door switch at that window is good.

2) Connect test lamp lead between blue wire (with tracer) and ground. If test lamp lights, circuit between individual switch and safety switch is good.

3) Disconnect orange and yellow leads at terminal plate. Connect orange wire to green lead and yellow wire to white lead. If window moves up and down as master switch is operated, switch at individual door is defective. If motor does not operate, remove door trim panel and check motor connections. If motor now operates, switch is defective. *NOTE* — It is possible that both motor and switch may be defective.

REMOVAL & INSTALLATION

FRONT DOOR WINDOW REGULATOR

Replacement — Disconnect battery. Remove arm rest, remote control handle, and window control switch escutcheon. Remove door lock button, trim panel, and water shield paper. With window in raised position, insert a drift into hole in the door inner panel to hold glass assembly. Remove two slide channel screws and four regulator mounting bolts. Remove lower division channel screw. Move regulator channel assembly arms forward and then to the rear to disengage glass bottom channels. Disconnect wiring. Move regulator arms up and out of opening in inner panel. Slide regulator and motor between inner panel and division channel to remove. To install, reverse removal procedure.

REAR DOOR WINDOW REGULATOR

Replacement — Disconnect battery. Remove arm rest and ash tray. Remove remote control handle and window regulator switch escutcheon. Remove door lock button, trim panel, and water shield paper. With window in raised position, insert a drift into hole in inner panel to hold glass. Remove two lower side channel screws and four regulator mounting bolts. Move regulator assembly forward and then to the rear to disengage glass bottom channels. Disconnect wiring. Move regulator arms up and out of inner panel opening, and remove motor and regulator. To install, reverse removal procedure.

Power Windows

AMERICAN MOTORS (Cont.)

MOTOR & DRIVE UNIT

CAUTION — Regulator arms and sector gear are under counterbalance spring tension. Secure sector gear to back plate with a bolt before removing motor and drive.

Replacement — Remove window regulator. To retain spring tension, drill a 1/4" hole in back plate under one of the existing holes in sector gear. Insert bolt and secure with a nut. Remove nuts attaching motor to drive unit and separate motor from drive. Insert a screwdriver blade into coupling and turn until spring tension on drive unit is relieved. Remove bolts securing drive unit to regulator. To install, reverse removal procedure.

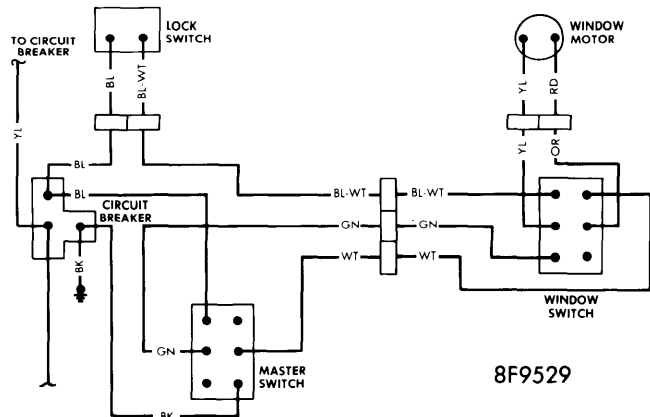

POWER WINDOW WIRING DIAGRAM