

## BUICK, CADILLAC, CHEVROLET & OMEGA CRUISE CONTROL

**Buick**  
**Cadillac**  
**Chevrolet**  
**Oldsmobile (Omega only)**

### DESCRIPTION

System uses manifold vacuum to power a throttle servo unit. When speed adjustment is necessary, servo moves the throttle by receiving a varying amount of controlled vacuum from a transducer unit. Speedometer cable (from transmission) drives transducer and a cable from transducer drives speedometer at instrument panel. Transducer is activated by a three-position switch located at end of turn signal lever. In addition, Cadillac models have an ON-OFF switch on instrument panel to completely shut system off.

### ON-OFF SWITCH

**Cadillac & Omega Only** — Switch is located on instrument panel along with an indicator light. This switch controls electrical current to system. With switch in "ON" position, system may be engaged at any speed above 24 MPH by using switch at turn signal lever.

### ENGAGEMENT SWITCH

Switch has three positions and is located in turn signal lever. To operate system, driver accelerates to desired speed and presses engagement switch in first detent position. *NOTE* — On Cadillac and Omega models, switch on instrument panel must be in "ON" position. Full voltage is then supplied to transducer solenoid which sets transducer to maintain car's speed at time of engagement. Releasing switch to full out position reduces current to solenoid. To increase or decrease set speed, driver must depress engagement switch to second (full in) detent position, which stops all current to solenoid and disengages system. Driver then either slows or accelerates to new speed desired and releases switch to full out position. Button passes through first detent (activating solenoid at new speed) and moves to full out position where it maintains solenoid in activated position. System will not operate at speeds below 35 MPH on Buick, 24 MPH on Cadillac or 30 MPH on Chevrolet and Omega. Driver may accelerate to speeds higher than set speed by depressing accelerator pedal, and upon release of pedal, car will resume set speed.

### BRAKE RELEASE SWITCH & VALVE

All models use two methods of disengaging system once it has been activated. When brake pedal is depressed, an electric release switch at brake pedal disengages solenoid in transducer, venting system vacuum to atmosphere through filter. Operation of engagement switch is required to reactivate system. If electric valve fails, a vacuum dump valve is also mounted at brake pedal and vents servo vacuum to atmosphere returning throttle to idle position.

### SERVO UNIT

Unit is a vacuum actuated variable position diaphragm assembly which operates carburetor throttle when system is in operation. It is powered by controlled vacuum from transducer and operates throttle linkage by means of a chain or rod.

### TRANSDUCER

Unit has two primary functions controlled by pull-in of solenoid. First, it is a vacuum switch and when engaged, it supplies vacuum to a "T" fitting. Second, it allows a metering valve clutch spring to grasp the rubber clutch which is fixed to speed cup spindle. A variation in speed results in a slight rotation of rubber clutch which moves air valve and meters a variable quantity of air to system where it blends with vacuum. Servo unit receives this controlled vacuum and maintains selected speed. Speedometer cable from transmission drives transducer speed sensing unit and transducer output cable drives speedometer head.

## TROUBLE SHOOTING & DIAGNOSIS

### WILL NOT ENGAGE — SYSTEM INOPERATIVE

ON-OFF switch (if used) is OFF. Brake switch circuit open. Fuse blown. Defective engagement switch. Vacuum leak in Servo and/or brake switch and connecting lines. Vacuum hose not connected to vacuum switch. Vacuum release switch misadjusted (always open). Crossed hose at regulator. Open in wiring harness. Pinched or plugged hose supplying servo. Defective regulator.

### DOES NOT CRUISE AT ENGAGEMENT SPEED

Orifice tube misadjusted.

### SYSTEM HUNTS, PULSES OR SURGES

Bead chain loose. Kinked or deteriorated hoses (air leak). Defective and/or improperly positioned drive cables and/or casing assemblies. Defective transducer.

### SYSTEM DOES NOT DISENGAGE WITH BRAKE PEDAL

Brake switches misadjusted or defective.

### SYSTEM ACCELERATES OR APPLIES FULL THROTTLE WHEN ENGAGED

Manifold vacuum connected directly to servo. Defective transducer.

### CANNOT ADJUST SPEED DOWNWARD WITH ENGAGE BUTTON

Defective engagement switch or wiring.

### SYSTEM CAN BE ENGAGED AT IDLE BY DEPRESSING SWITCH, BUT DROPS OUT WHEN SWITCH IS RELEASED

Wires reversed at transducer.

### SYSTEM OPERATES CORRECTLY, BUT VACUUM BLEEDS OFF WHEN SYSTEM DISENGAGED

Crossed vacuum hoses at transducer.

### DOES NOT ENGAGE OR ENGAGES AT SPEEDS LOWER THAN 30 MPH

Defective transducer.

## BUICK, CADILLAC, CHEVROLET & OMEGA CRUISE CONTROL (Cont.)

### TESTING

#### ENGAGEMENT SWITCH

1) Disconnect switch harness three wire connector at lower part of steering column. *NOTE — Wire colors are the same in all models except where noted.* Connect an ohmmeter between terminal number 1 (brown wire) and terminal number 2 (blue wire). Continuity should be maintained until switch is pressed all the way in.

2) Connect ohmmeter between terminal number 1 (brown wire) and terminal number 3 (black wire). No continuity should be shown. With button partially depressed, ohmmeter should show continuity. With button fully depressed, ohmmeter should again show no continuity.

3) Connect ohmmeter between terminal number 2 (blue wire) and terminal number 3 (black wire). No continuity should be shown. With button partially and then fully depressed, continuity should be shown.

#### ENGAGEMENT SWITCH WIRING HARNESS

1) Disconnect switch harness three wire connector at lower part of steering column. Disconnect battery ground cable.

Connect ohmmeter between brown/white wire (dk. blue wire on Cadillac) in main wire harness and ground. Make sure regulator is well grounded. Ohmmeter should read 42-49 ohms.

2) If resistance is above or below specified value, disconnect harness connector at transducer and measure resistance of brown/white (white on Cadillac) resistor wire. Resistance should measure  $40 \pm 2$  ohms. If resistance not as specified, replace wire harness.

#### TRANSDUCER SOLENOID COIL CIRCUIT

Measure resistance of solenoid coil circuit by connecting ohmmeter between hold terminal and ground. Resistance should be between 5 and 6 ohms. A reading of less than 4 ohms indicates coil circuit is shorted. A reading of more than 7 ohms indicates excessive resistance in coil circuit. If either condition exists, transducer must be replaced. Check black (white on Chevrolet) wire in main wiring harness between switch and transducer for continuity.

#### SERVO & VACUUM

To determine the condition of the diaphragm, remove hose from the servo unit and apply 14 inches of vacuum to the tube opening and hold in for one minute. The vacuum

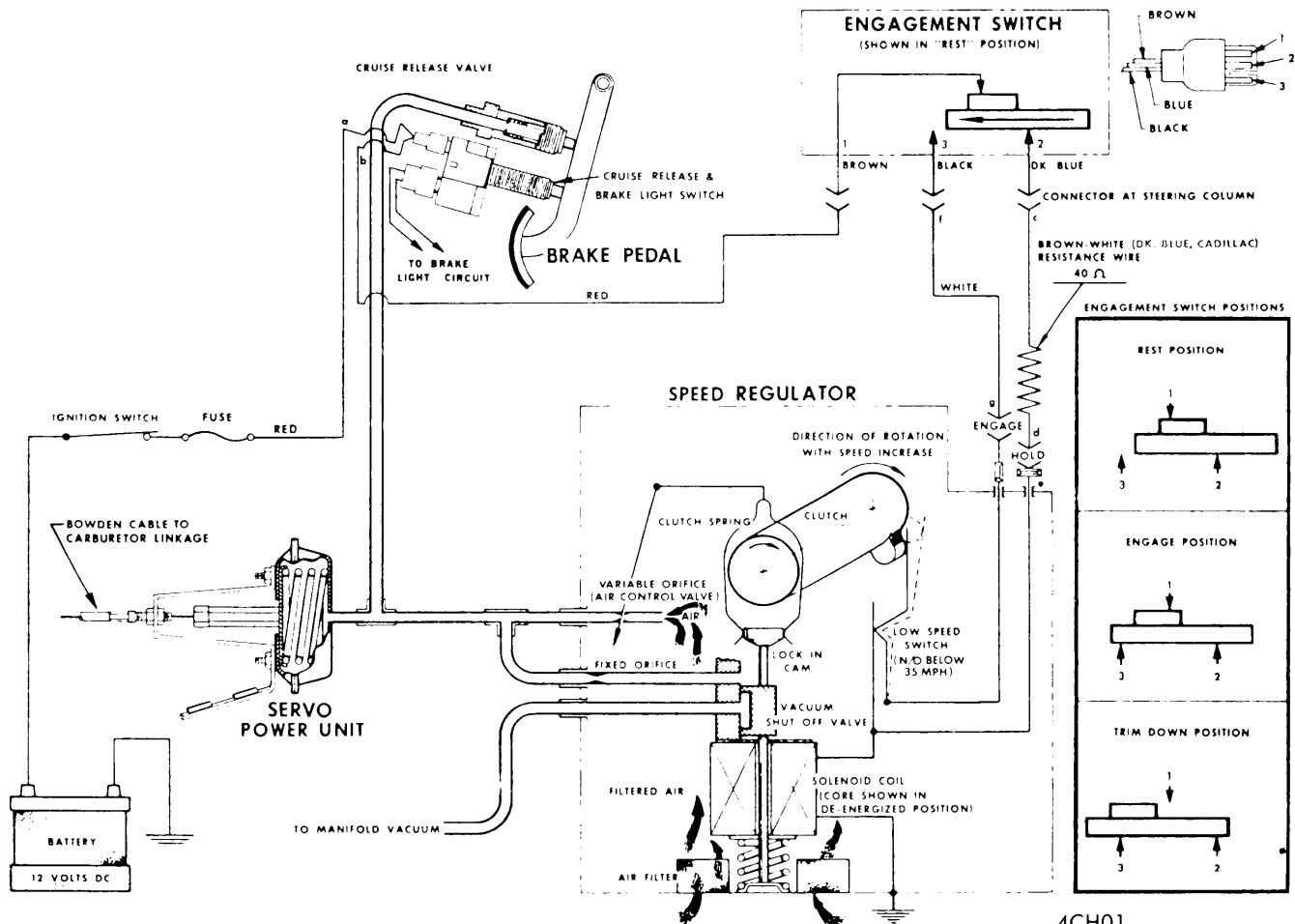

**CHEVROLET VACUUM & ELECTRICAL DIAGRAM  
(OTHER MODEL SYSTEMS SIMILAR)**

## BUICK, CADILLAC, CHEVROLET &amp; OMEGA CRUISE CONTROL (Cont.)

should not leak down more than five inches of vacuum in one minute. If leakage is detected, replace servo. To utilize the engine as a vacuum source, proceed as follows:

1) DISCONNECT SERVO BEAD CHAIN and hose from servo unit, connect engine vacuum directly to the servo fitting.

2) Note position of servo diaphragm. Start engine: The diaphragm should pull in. Clamp off engine vacuum supply line and check for leakage.

## VACUUM BRAKE SWITCH

The Cruise Control vacuum operated release brake switch and connecting hoses can be checked with the aid of a vacuum pump.

## ELECTRIC BRAKE SWITCH

Check fuse and connector. Unplug electric brake switch connector at switch. Connect an ohmmeter between two terminals at switch. Ohmmeter must indicate infinity when brake pedal is depressed, and continuity when pedal is released. Replace switch if necessary.

## ADJUSTMENTS

*NOTE* — The components of the Vacuum Cruise Control System are designed to be replaced should they become inoperative. However, the following adjustments may be made to correct speed drop or increase, or misalignment of the brake switch.

## ELECTRIC BRAKE RELEASE SWITCH

**Buick** — With brake pedal fully depressed, push switch forward until it contacts or stops against bracket or arm. Pull pedal back with 15 to 20 pounds force. This will automatically adjust switch.

**Cadillac, Chevrolet & Omega** — Brake release switch contacts must open, checked with a test lamp, when brake pedal is depressed  $\frac{1}{4}$  -  $\frac{3}{8}$ " (Cadillac),  $\frac{3}{8}$  -  $\frac{5}{8}$ " (Chevrolet) and  $\frac{1}{4}$  -  $\frac{1}{2}$ " Omega. The switch must always be adjusted to open before dump valve, otherwise a hiss will be heard inside car when brakes are applied.

## VACUUM BRAKE RELEASE SWITCH

**Buick, Cadillac & Omega** — The vacuum brake release switch is adjusted in the same manner as the Buick electric brake release switch.

**Chevrolet** — Brake switch should vent the vacuum system when pedal is depressed  $\frac{3}{16}$ ", measured at switch.

## ENGAGEMENT SWITCH

The engagement switch is serviced only by replacement.

## SERVO UNIT (BEAD CHAIN)

*NOTE* — DO NOT lubricate servo unit or its bead chain.

**Buick** — Adjust engine hot idle speed and mixture, then shut off engine. Check bead chain slack by unsnapping swivel from ball stud and holding chain taut at ball stud. Center of swivel should extend  $\frac{1}{8}$ " beyond center of ball stud. Adjust slack, if

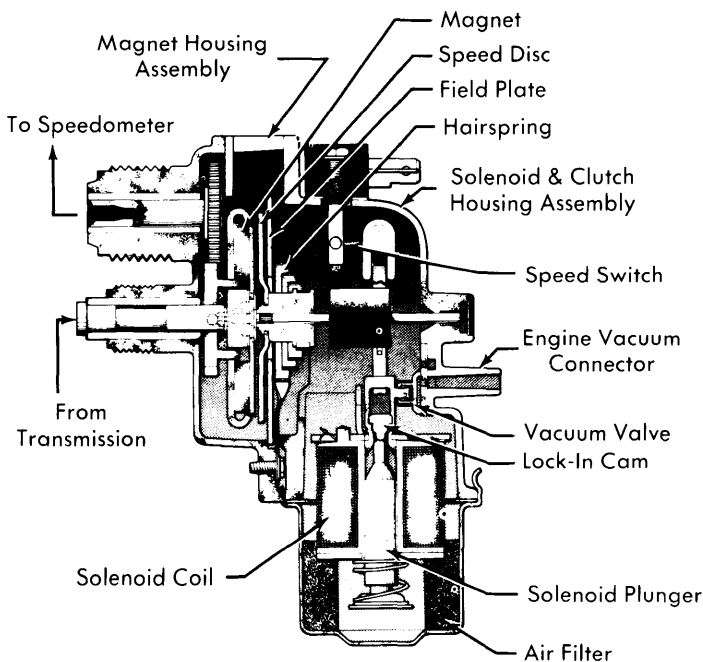

Side View

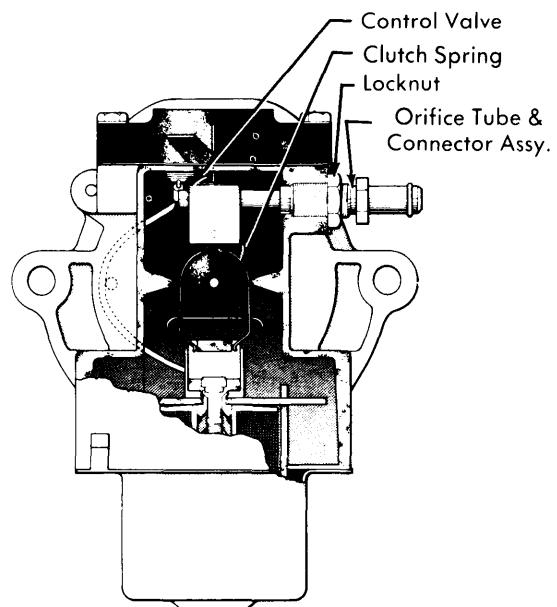

End View

## TRANSDUCER CROSS SECTION (ALL MODELS)

4CA03

## BUICK, CADILLAC, CHEVROLET & OMEGA CRUISE CONTROL (Cont.)

necessary, by removing retainer from swivel and chain assembly and position chain into cavity that will allow a slight amount of slack in chain. Install retainer over swivel and chain assembly.

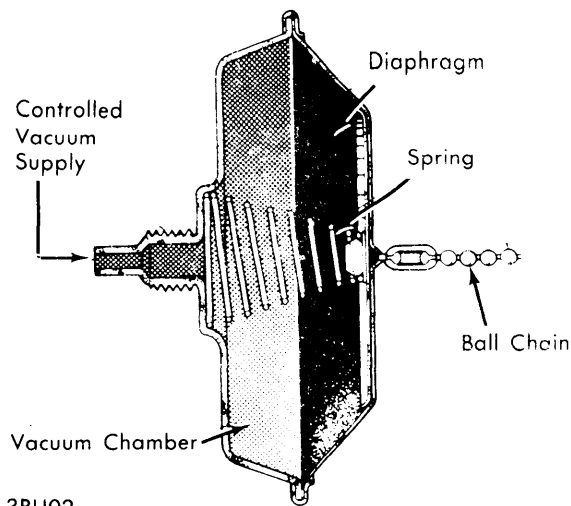

SERVO UNIT CROSS SECTION

**Cadillac** — Install bead chain with second ball on inboard slot of throttle plate clip.

**Chevrolet** — Install second ball of bead chain into pocket on servo cable. With throttle completely closed, ignition off and fast idle cam on low step, adjust cable jam nuts until servo chain has a slight amount of slack. Tighten jam nuts and pull servo rubber boot over washer on chain.

**Omega** — With slow idle correctly adjusted, carburetor at slow idle position and ignition off, remove retainer clip from servo rod. Select a hole in rod that will provide slight clearance between clip and servo bushing when clip is installed. Clearance should not exceed width of one hole.

### TRANSDUCER

1) Before any adjustment is made to transducer, inspect all vacuum hoses for damage. All hoses should be properly connected, not kinked or pinched, and no leaks should be detected. Check, and if necessary, adjust electric and vacuum brake release switches (as previously outlined). Check, and if necessary, adjust servo bead chain (as previously outlined).

2) If cruising speed is lower than the engaged speed, loosen the orifice tube locknut and turn the tube outward. If cruising speed is higher than engagement speed, turn orifice tube inward. Each  $\frac{1}{4}$ " turn will alter engagement cruising speed 1 MPH. Tighten the adjustment locknut and check system operation at 60 MPH.