

MOTORCRAFT

Ford Motor Co.

DESCRIPTION

Ford alternators are 12 volt negative ground units. Alternator amperage outputs range from 38 to 90 Amps. Alternators use six diodes, except the 61 Amp. alternator uses eight diodes. Alternators with 70 and 90 Amp. capacities are side terminal units. Alternator regulators are either electro-mechanical or transistorized.

CAUTION – Before servicing alternator or regulator, note the following precautions to avoid component damage.

Battery – Do not reverse battery connections. Negative terminal must be connected to ground. When charging battery, cables must be disconnected from battery before connecting charger. *DO NOT use a charger as a booster for starting engine.* If a booster battery is used to start engine, negative cable of booster battery must be connected to car battery negative terminal.

Alternator – DO NOT ground field circuit between alternator and regulator or operate alternator on an open circuit with field winding energized. DO NOT ground output terminal or attempt to polarize alternator as polarization is not required.

Regulator – Turn ignition switch off when working on regulator. Use care to prevent a short circuit between voltage regulator relay and regulator base when working on regulator. Use an insulated tool when making adjustments.

IDENTIFICATION & SPECIFICATIONS

Alternator is ink stamped with "FoMoCo" or "Motorcraft" trademarks. Color stamp and amperage rating are purple (38A), orange (42A), red (55A), and green (61A). No color code is used for 70 and 90 Amp. alternators. Rated alternator output is stamped on end frame. Charging circuits and alternator are protected by in-line fuse links located between alternator "BAT" terminal and starter solenoid.

Alternator	Amps.
D2ZF-AC	38
D3ZF-AA	38
D4ZF-BA	38
D42F-AA	38
D42F-EA	38
D42F-FA	38
D52F-AA	38
D20F-DB	42
D20F-GA	42
D30F-FA	42
D3TF-CA	42
D20F-BB	55
D20F-EB	55
D20F-HA	55
D2SF-AB	55
D30F-BA	55
D30F-CA	55
D40F-BA	55
D40F-CA	55
D40F-FA	55
D5AF-CA	60
D5AF-DA	60
D5AF-EA	60
D5AF-FA	60
D5AF-GA	60
D5AF-KA	60
D5AF-LA	60

D2DF-AC	61
D20F-CB	61
D20F-KA	61
D2TB-BA	61
D22F-BA	61
D3DF-AA	61
D30F-EA	61
D3UF-AA	61
D32F-BA	61
D4DF-AA	61
D40F-AA	61
D40F-DA	61
D4UF-AA	61
D42F-BA	61
D2AF-EA	70
D20F-AA	70
D20F-BA	70
D20F-GA	70
D22F-BB	70
D30F-AA	70
D32F-AA	70
D40F-EA	70
D4SF-AA	70
D4ZF-AA	70
D4ZF-CA	70
D42F-CA	70
D5DF-AA	70
D50F-AA	70
D3VF-AA	90
D3VF-AB	90
D3VF-BA	90

Specifications

Alternator	Specification
All 38-61 Amp.	
Field Current @ 12V	2.5 Amps.
All 70 & 90 Amp.	
Field Current @ 12V	2.9 Amps.
All Alternators	
Slip-Ring	
Min. Dia.	1.22"
Max. Runout	.0005"
Brush Length Wear Limit	.3125"
Pulley Nut Torque	60-100 ft. lbs.

TESTING

NOTE – Alternator output test using Rotunda ARE 27-38, ARE 20-23, and ARE 21-055 Volt-Amp Alternator testers are to be discontinued because of possible damage to the breakerless electronic ignition module and other electronic devices.

VOLTMETER TEST PROCEDURE

NOTE – When performing charging system tests with a voltmeter, turn off all lights and electrical components unless otherwise specified. Battery specific gravity must be 1.200 or higher before testing system.

1) Connect voltmeter leads to battery and record battery voltage. Connect a tachometer and operate engine at 1500 RPM with no electrical load. The voltmeter reading should increase 1 volt and not exceed 2 volts above first recorded battery voltage. Read voltage when voltmeter stops moving.

2) With engine operating, turn on heater blower motor (high speed) and turn headlights on high beam. Increase engine

MOTORCRAFT (Cont.)

speed to 2000 RPM. Voltmeter should indicate a minimum of 0.5 volt above the first recorded battery voltage. If voltage tests indicate proper voltage readings, the charging system is satisfactory; if not, proceed to Tests Results.

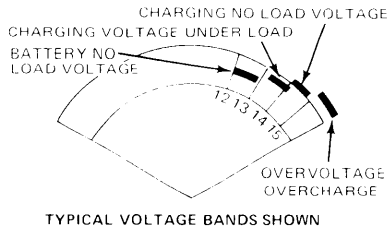

3F756

VOLTMETER TEST SCALE

TESTS RESULTS

- 1) If voltmeter reading indicates over voltage (more than two volts above battery voltage), stop engine and check ground connections between regulator and alternator and/or regulator and engine. Clean and tighten connections securely and repeat test.
- 2) If over voltage still exists, disconnect regulator wiring plug and repeat tests. If over voltage condition disappears, replace voltage regulator and repeat tests.
- 3) If over voltage still exists with regulator disconnected, a short is indicated in wiring harness between alternator and regulator. Repair short circuit, then replace voltage regulator and repeat tests with regulator plug connected.
- 4) If voltmeter reading does not increase at least one volt, check for presence of battery voltage at alternator "BAT" terminal, and at regulator plug "A" terminal. If no voltage is present, an open wire is indicated.

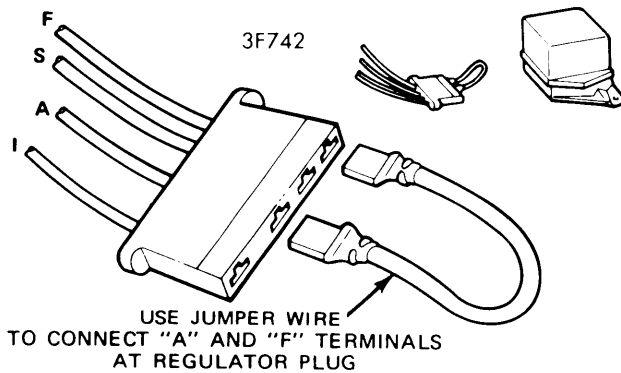

REGULATOR PLUG JUMPER WIRE CONNECTION

- 5) Before performing other tests, the field circuit (regulator plug to alternator) must be checked for a grounding condition. If the field circuit is grounded and the jumper wire is used as a check at regulator wiring plug from "A" to "F" terminals, excessive current will cause heat damage to regulator wiring plug terminals and may burn the jumper wire. Also if the field circuit was grounded, the connector wire inside the regulator will be burned open and an under voltage condition will result.
- 6) Field circuit should be checked with the regulator wiring plug disconnected and an ohmmeter connected from "F" terminal of regulator plug to battery ground. Ohmmeter should

indicate 4-250 Ohms. A lower reading indicates a short or ground circuit in field (including alternator).

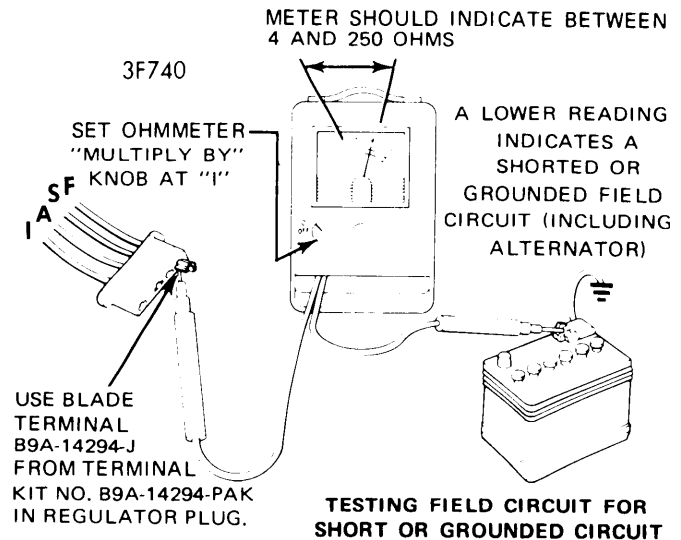

TESTING FIELD CIRCUIT WITH OHMMETER

- 7) Check regulator for a burned open wire by connecting an ohmmeter between "I" and "F" terminals on regulator. Zero Ohms is normal between terminals; if ohmmeter reads about 10 Ohms, the connector wire inside regulator is burned open. Repair field circuit ground before installing a new regulator.

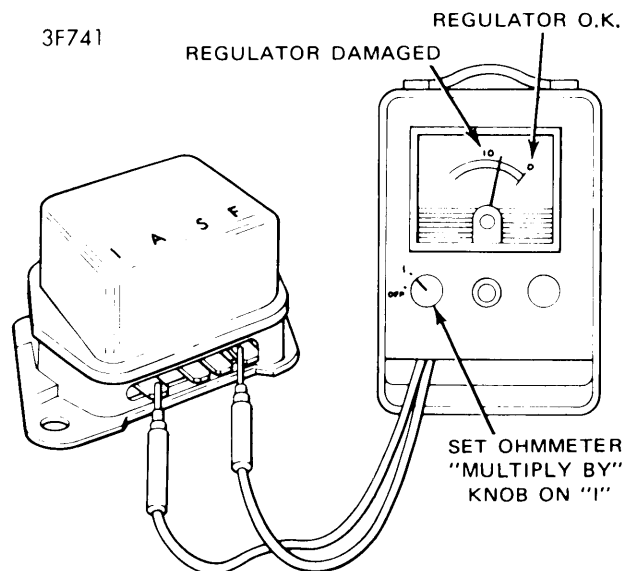

TESTING REGULATOR FOR BURNED OPEN WIRE

FIELD CIRCUIT & ALTERNATOR TESTS

If the field circuit is satisfactory, step 6) in Test Results, disconnect regulator wiring plug at regulator and connect a jumper wire between "A" and "F" terminals on regulator wiring plug. Repeat voltmeter tests procedures. If a problem of under voltage still exists, remove jumper wire and leave regulator plug disconnected; then connect a jumper wire to the "FLD" and "BAT" terminals on alternator (see illustrations). Repeat voltmeter tests procedure. If results are now satisfactory,

MOTORCRAFT (Cont.)

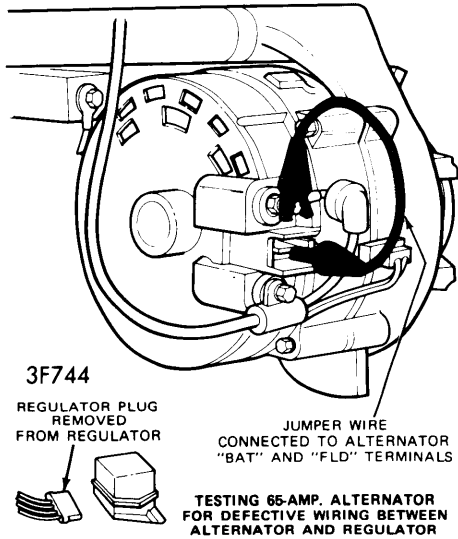

SIDE TERMINAL JUMPER WIRE CONNECTION

repair wiring harness from alternator to regulator. Reconnect regulator wiring plug and repeat voltmeter tests procedure to check system operation. If test results still show under voltage, repair or replace the alternator.

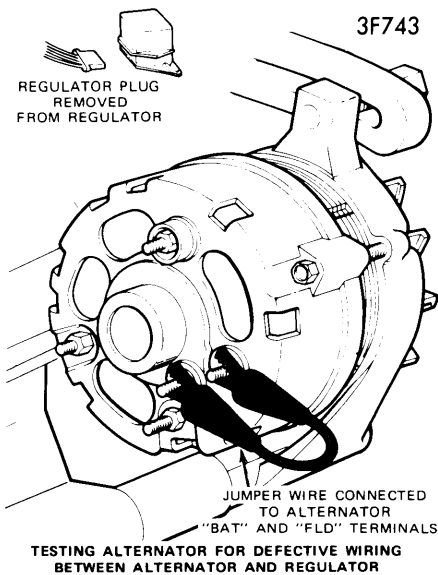

REAR TERMINAL JUMPER WIRE CONNECTION

REGULATOR CIRCUIT TESTS

"S" Circuit With Ammeter – Connect positive voltmeter lead to regulator wiring plug "S" terminal position. Turn ignition "ON", but do not start engine. Voltmeter should indicate battery voltage; if there is no voltage, the "S" wire lead from ignition switch is open. Repair and retest system.

"S" & "I" Circuit With Indicator Light – Disconnect regulator wiring plug and install a jumper wire between "A"

and "F" terminals. With engine idling, connect positive lead of voltmeter to "S", and then "I" terminals of regulator wiring plug. Voltage of "S" circuit should be about one half of "I" circuit. If no voltage is present, repair alternator or wiring circuit at fault. If circuit tests are satisfactory, install a new regulator.

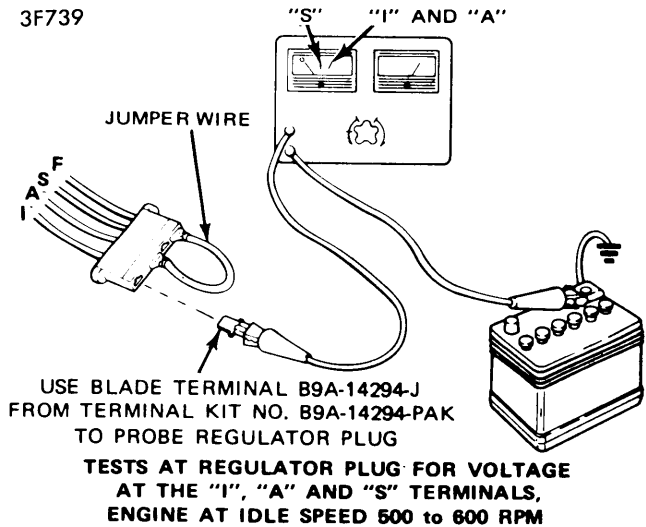

REGULATOR PLUG VOLTAGE TEST

BENCH TESTING

Rotor Field – With rotor removed from alternator rear housing, connect ohmmeter to rotor slip rings; meter reading should be 3.5-4.5 ohms. A higher reading indicates a damaged slip ring solder connection or broken wire. A lower reading indicates a shorted wire or slip ring. Check rotor for grounds by connecting ohmmeter from slip ring to rotor shaft; no continuity should exist.

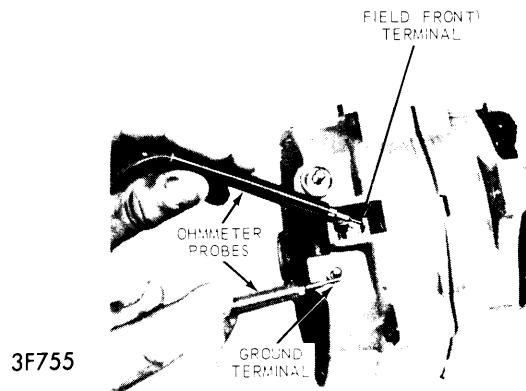

FIELD OPEN OR SHORT CIRCUIT TEST

Diode Assembly – With stator leads disconnected from diode assemblies, connect an ohmmeter as shown in illustrations. Then reverse ohmmeter leads and repeat test for each diode. All diodes should show a low reading of about 60 ohms in one direction and infinite reading in other direction.

MOTORCRAFT (Cont.)

Stator Windings — Check stator for grounds by connecting an ohmmeter to one stator lead and laminated core. No continuity should exist.

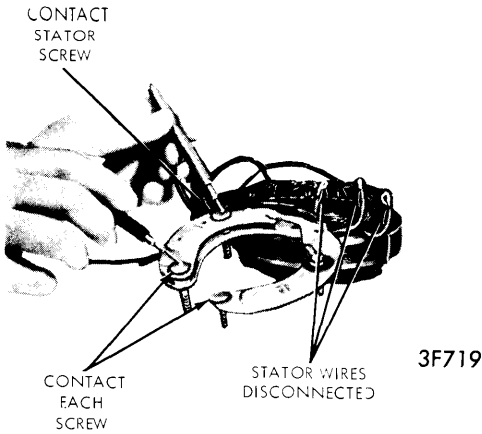

use a fiber rod as a screwdriver for this adjustment. Turn screw clockwise to increase the voltage setting; counterclockwise to decrease the voltage setting.

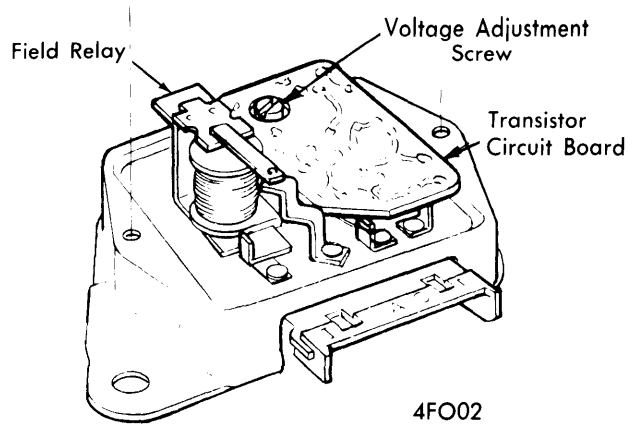

DIODE TEST CONNECTIONS — 61 AMP.

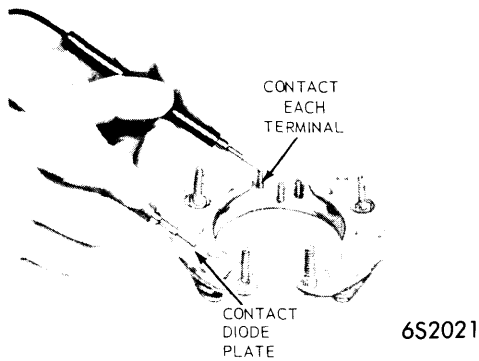

TRANSISTORIZED REGULATOR

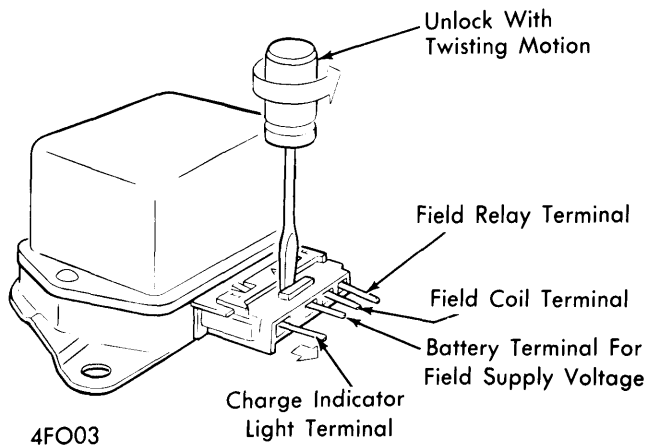

DIODE TEST CONNECTIONS — EXC. 61 AMP.

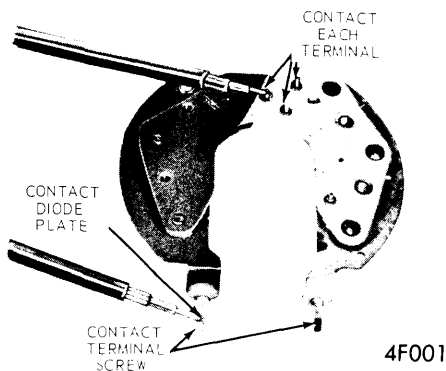

REGULATOR WIRE HARNESS CONNECTOR (TYPICAL)

OVERHAUL

DIODE TEST — SIDE TERMINAL ALTERNATOR

ADJUSTMENTS

ALTERNATOR REGULATORS

Electro-Mechanical Type — Regulator is factory calibrated and is not to be adjusted.

Transistorized Type — The only adjustment on transistorized regulators is the voltage limiter adjustment. With the regulator at normal operating temperature, remove regulator cover and

DISASSEMBLY

G.P.D. Rear Terminal — Mark both end housings and stator with a scribe mark for assembly. Remove thru bolts. Separate front housing and rotor from stator and rear housing. Remove all nuts and insulators from rear housing and remove rear housing from stator.

2) Remove brush holder mounting screws, and remove holder, brushes, springs, insulator, and terminal. If replacement is necessary, press bearing from rear housing, supporting housing on inner bore. If rectifier assembly requires replacement, unsolder stator leads from printed circuit board and separate stator from rectifier. Use a 100 watt soldering iron.

3) Original production alternators will have one of three types of rectifier circuit boards; one has circuit board spaced away from diode plates with diodes exposed, a second type is a single circuit board with built in diodes, and the third type has built in diodes with an additional booster diode plate containing two diodes (used on 61 Amp. alternators only).

Alternators & Regulators

MOTORCRAFT (Cont.)

4) If alternator rectifier has an exposed diode circuit board, remove screws from rectifier by rotating bolt heads 1/4 turn clockwise to unlock and remove them. Push stator terminal screw straight out on a rectifier with diodes built into circuit board, avoid turning screw while removing to make certain that the straight knurl will engage insulators when installing. Do not remove grounded screw.

5) On 61 Amp. alternator rectifier, press stator terminal screw from circuit board with a vise, back up terminal board with a 1/2" drive 1/2" socket. Leave nut on end of terminal to keep from damaging threads. When terminal has moved about 1/4" remove nut, and lift screw from board.

6) Remove pulley as shown in illustration. Then remove fan, fan spacer, front housing and rotor stop.

7) Remove front bearing retainer. If bearing is damaged or has lost its lubricant, support housing close to bearing boss and press out old bearing. With alternator now fully disassembled perform a diode test.

REASSEMBLY

1) Rotor, stator and bearings must not be cleaned with solvent, simply wipe with a clean cloth. Press front bearing in housing applying pressure on outer race only, then install retainer. If stop ring on rotor drive was damaged, install a new ring. Push new ring on shaft and into groove, do not open ring with snap ring pliers as it will stretch.

2) Position rotor stop on drive shaft with recessed side against stop ring. Position front housing, fan, spacer, pulley, and lock washer on drive shaft and install retaining nut. If rear housing bearing was removed, support housing on inner boss and press new bearing flush with outer end surface.

3) Place brush springs, brushes, brush terminal and terminal insulator in brush holder. Hold brushes in place by inserting a stiff piece of wire in brush holder (see illustration). Position brush holder assembly in rear housing, and install mounting screws. Wrap the three stator winding leads around circuit board terminals and solder them in place, be sure to use rosin core solder.

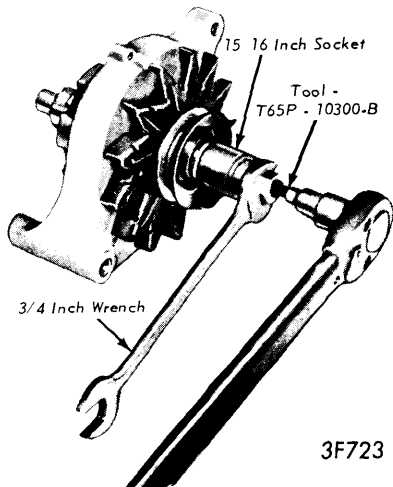

3F723
REMOVING ALTERNATOR PULLEY

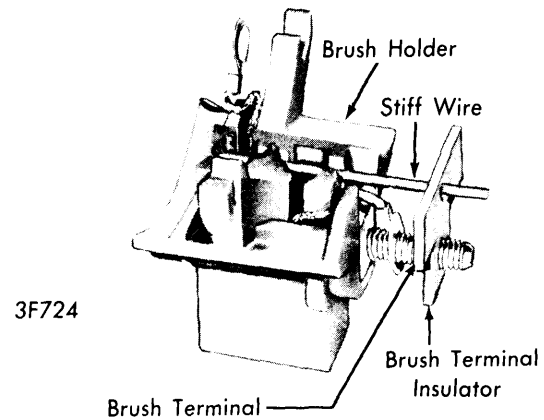

3F724
INSTALLING BRUSHES IN BRUSH HOLDER

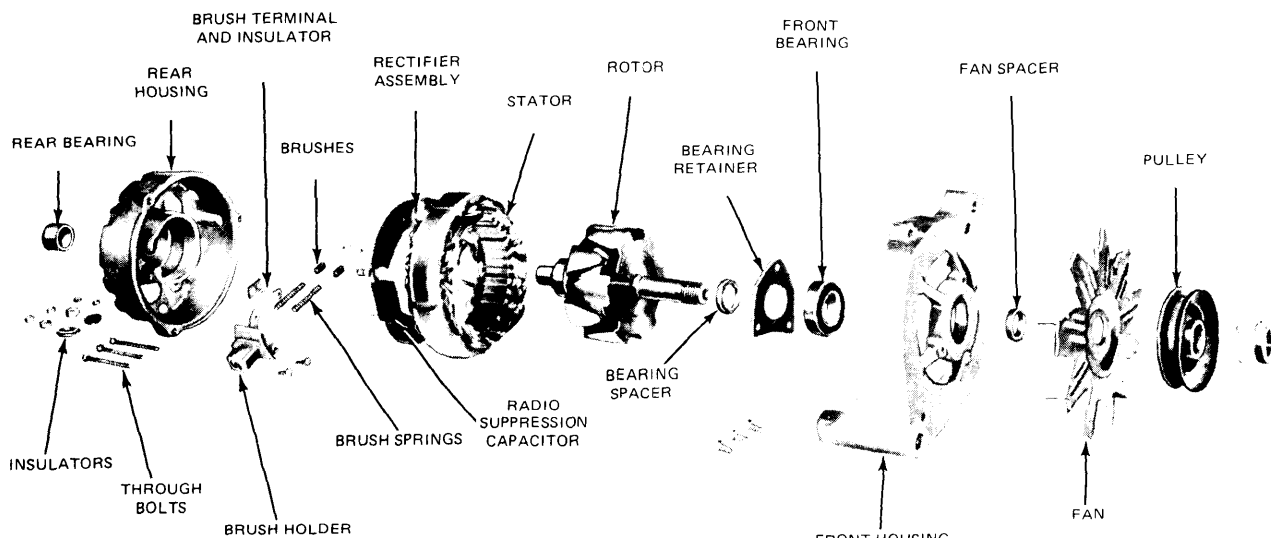

3F722

REAR TERMINAL ALTERNATOR

MOTORCRAFT (Cont.)

4) Position stator neutral lead eyelet on stator terminal screw and install screw in rectifier assembly. For a rectifier with diodes exposed, insert the special screws thru wire lug, dished washers and circuit board. Turn 1/4 turn counterclockwise to lock. For single circuit boards with built in diodes, insert screws straight thru wire lug, insulating washer, and rectifier into square hole in rectifier into the insulator. Dished washers are used on exposed diode circuit boards only.

5) For a rectifier with a booster diode plate (61 Amp.), position stator wire terminal on stator terminal screw and position screw into rectifier. Position square insulator over screw and into square hole in rectifier. Rotate terminal screw until it locks into position, then press screw in finger tight. Install stator wire. Now press terminal screw into rectifier and insulator, using a vise and a 3/8" drive 3/8" socket.

6) Position radio noise suppression capacitor on rectifier terminals. On circuit boards with exposed diodes, install the "STA" and "BAT" (see illustration) terminal insulators. On single circuit boards, position the square stator terminal insulator in the square hole in rectifier assembly. Position "BAT" terminal insulator.

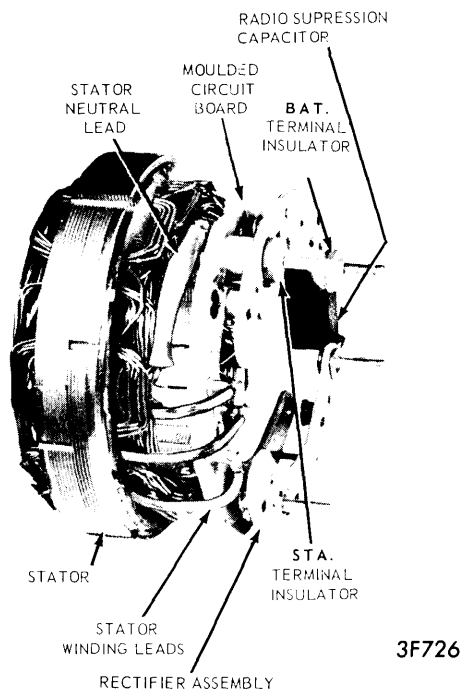

STATOR LEAD CONNECTIONS - EXC. 61 AMP.

7) Position stator and rectifier assembly in rear housing, make certain all terminal insulators are seated properly in the recesses. Position the "STA" (black), "BAT" (red), and "FLD" (orange) insulators on terminal bolts and install retaining nuts.

8) Position rear housing and stator assembly over rotor and align scribe marks made prior to disassembly. Seat machined portion of stator core into step in both end housings. Install thru bolts. Remove brush retracting wire, and put a daub of water proof cement over hole to seal it.

DISASSEMBLY

G.P.D. Side Terminal - Mark both end housings with a scribe mark for assembly. Remove thru bolts, and separate front housing and rotor from rear housing and stator. Do not separate rear housing from stator at this time.

2) Remove pulley drive nut, and pulley (see step 6 in rear terminal disassembly) fan, and fan spacer from rotor shaft. Pull rotor and shaft from front housing and remove spacer from rotor shaft. Remove three screws retaining bearing to front housing. If bearing is defective, support housing close to bearing boss and press out bearing.

3) Unsolder three stator leads from rectifier. Use a 200 watt iron. Lift stator from housing. Unsolder brush holder lead from rectifier. Remove capacitor lead from rectifier, and remove rectifier from rear housing.

4) Remove brush holder, remove any sealing compound from holder. Remove capacitor from rear housing. If bearing replacement is necessary, support rear housing close to bearing boss and press bearing out of housing from inside.

REASSEMBLY

1) Rotor, stator and bearings must not be cleaned with solvent, simply wipe with a clean cloth. If front bearing is being replaced, press in new bearing applying pressure to outer race only. Install bearing retainer.

2) Place inner spacer on rotor shaft and insert rotor shaft into front housing and bearing. Install fan spacer, fan, pulley, lockwasher and nut. If rear bearing is being replaced, press a new bearing in from inside the housing until it is flush with boss on outer surface.

3) Position brush terminal on brush holder. Install springs and brushes in brush holder, and insert a stiff wire to hold brushes in place. Position brush holder in rear housing and install screws. Push holder toward rotor shaft opening and tighten brush holder attaching screws.

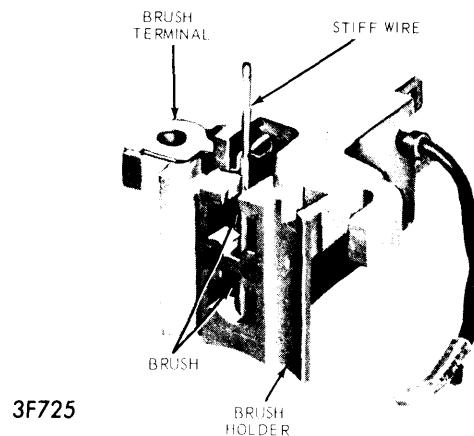

INSTALLING BRUSHES IN BRUSH HOLDER

Alternators & Regulators

MOTORCRAFT (Cont.)

4) Place two cup shaped (rectifier) insulators on bosses inside housing. Place insulator on "BAT" (large) terminal of rectifier in rear housing. Place outside insulator on "BAT" terminal, and install nuts on "BAT" and "GRD" terminals, finger tight. Install but do not tighten rectifier attaching screws. Tighten "BAT" and "GRD" terminal nuts on outside of rear housing. Then tighten four rectifier attaching screws.

5) Position capacitor lead to rectifier and install screw. Press brush holder lead on rectifier pin and solder securely. Position stator in rear housing and align scribe marks made before disassembly. Press three stator leads on rectifier pins and solder securely. Position rotor and front housing into stator and rear housing. Align scribe marks and install thru bolts. Spin pulley to be sure nothing is binding. Remove wire retracting brushes, and place a daub of waterproof cement over hole to seal it.

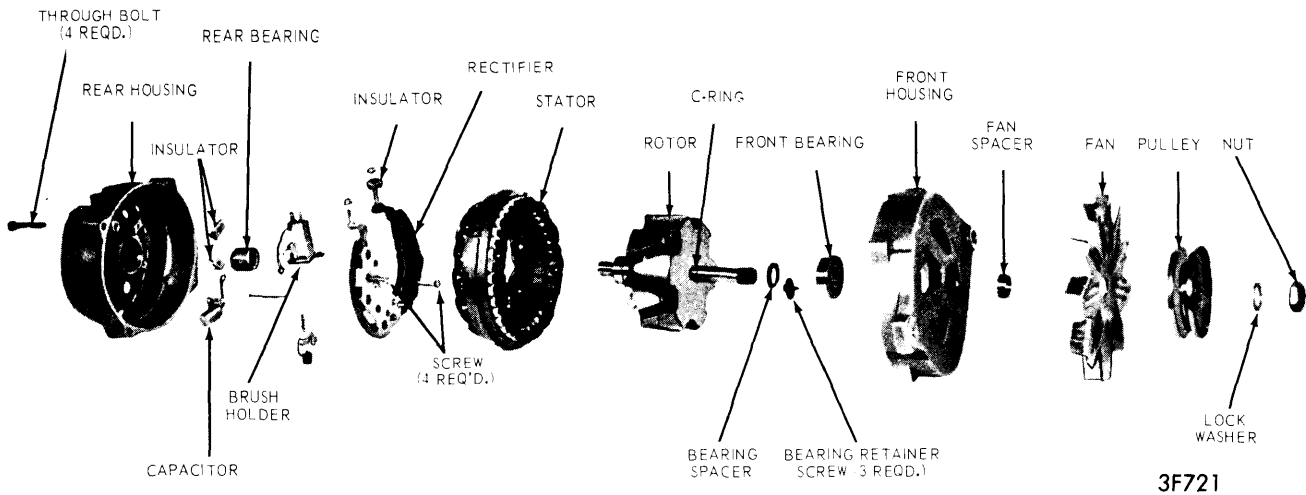

SIDE TERMINAL ALTERNATOR