

CHRYSLER CORP. REGULATOR

Chrysler No. 3755 850 (100 amp.).
Chrysler No. 3755 960 (All Others).

DESCRIPTION

Regulates electrical system voltage by limiting output voltage generated by alternator. This is accomplished by controlling amount of current that is allowed to pass through alternator field winding. Regulator has no moving parts and requires no adjustment after it is set at factory. Unit contains several semiconductor components, transistors and diodes plus some resistors and a capacitor. A large transistor is placed in series with alternator field winding and a control circuit which senses system voltage and turns transistor on and off as required. As alternator speed and electrical system load conditions change, control circuit is turning transistor on and off many times per second most of the time engine is in operation. The only time transistor is not turning on and off rapidly, is during low engine speed operation when high electrical loads are present (which require alternator field to be in the on state continuously). Electronic regulator control circuit can also vary the regulated system voltage up or down as temperature changes.

OPERATION

On all 1975 models except Dart and Valiant, a Field-Loads Relay is used in conjunction with the regulator. Relay is located between battery and regulator. It brings the regulator electrically closer to battery voltage, reduces voltage drop between battery and regulator and makes regulator more sensitive to battery requirements. With field-loads relay, battery is protected from over charging and improves cold starts by disconnecting nonessential circuits during cranking.

TESTING

NOTE — Battery specific gravity should be above 1.200 for a proper regulated voltage check. Charge battery or use a good test battery before testing regulator.

NOTE — Where tester (C-4133) is available, use adapter (C-4341) to switch circuit of regulator to be tested. Adapter (C-4341) has a three position switch to select regulator part number of regulator installed. Follow manufacturers test procedures.

1) On Models without field-loads relay, connect positive lead of voltmeter to terminal of ballast resistor with blue or blue-black wires connected to it. DO NOT remove connector from ballast resistor. On models with field-loads relay connect positive lead of voltmeter to positive post of battery. Connect negative lead to a good vehicle ground.

2) Start and run vehicle at 1250 RPM with all lights and accessories turned off. Check voltmeter, regulator is working properly if voltage readings are within specifications.

3) If voltage is not within limits or is fluctuating, check that regulator has a good ground. With engine off, disconnect regulator terminals. Turn ignition on, but do not start engine. Battery voltage should appear at both blue and green leads of connector. On vehicles with field-loads relay, check for proper operation of relay. If all tests are satisfactory, replace regulator and repeat tests.

4) To test field-loads relay, disconnect wiring harness connector at voltage regulator. Connect ground lead of voltmeter to a good vehicle ground and turn ignition switch on, but DO NOT start engine. If battery voltage is measured at terminals, relay is working correctly. If voltage is not present at connector and circuit wiring checks all right, relay is malfunctioning and must be replaced.

Specifications

Ambient Temperature [ⓐ]	Voltage Range
-20°F	14.9-15.9
80F	13.9-14.6
140°F	13.3-13.9
Above 140°F	Less than 13.6

[ⓐ] — Ambient temperature is measured ¼ " from regulator.

ADJUSTMENT

The Electronic Voltage Regulator cannot be adjusted. If specifications are not obtained and investigation has proved that the rest of the electrical system is not at fault, regulator must be replaced.

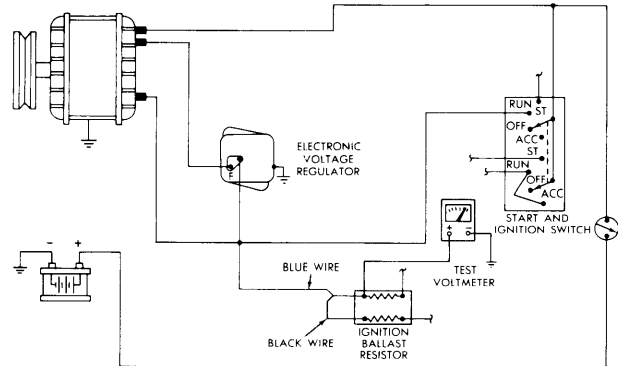

5CR1

VOLTAGE REGULATOR TEST (VALIANT & DART)

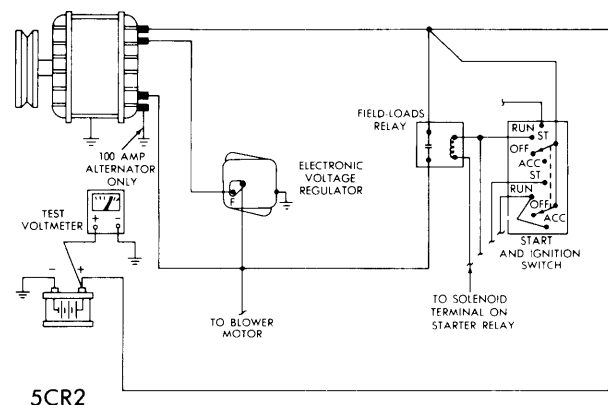

5CR2

VOLTAGE REGULATOR TEST (EXC. VALIANT & DART)