

# Windshield Wipers

## 1971-74 GENERAL MOTORS - ROUND MOTOR

### 1973-74

GM Division	Body Type	Car Name
Buick	A	Century, Regal
Chevrolet	A	Chevelle, Monte Carlo
Oldsmobile	A	Cutlass
Pontiac	A	LeMans, Grand Prix
Buick	B	LeSabre, Centurion
Chevrolet	B	Biscayne, Bel Air
	B	Impala, Caprice
Oldsmobile	B	Delta
Pontiac	B	Catalina, Bonneville
	B	Grand Ville
Buick	C	Electra
Cadillac	C	Fleetwood, Calais
	C	DeVille
Oldsmobile	C	Ninety Eight
Buick	E	Riviera
Cadillac	E	Eldorado
Oldsmobile	E	Toronado
Chevrolet	F	Camaro & Custom
Pontiac	F	Firebird

### Wiper Arm Adjustment

- 1) With cowl vent screen removed, remove right arm and blade assembly on "A" and "F" styles.
- 2) Loosen (not remove) transmission drive link crankarm attaching nuts. On all styles except "A" and "F", if only one arm needs adjustment, loosen only the drive link nuts for the unit requiring adjustment.
- 3) Rotate the left arm assembly on "A" and "F" styles and both arm assemblies on all other styles to a position 1" below the blade stops. *NOTE - On all styles except "A" and "F" bodies, even if only one arm requires adjustment, right and left assemblies must be rotated 1" below stops.* Tighten the attaching nuts on the drive link(s) to motor crankarm.
- 4) On "A" and "F" styles, position the right arm 1" below the blade stop and install arm assembly to shaft. Lift the right and left arms over the stops.
- 5) Check wipe pattern and park position (see following for check dimensions).

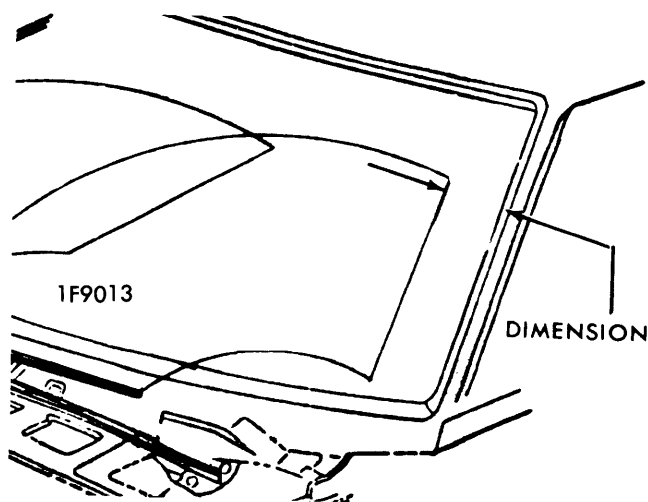

WIPER PATTERN CHECK

**Wipe Pattern Check Dimensions** - In the following table, the dimension(s) given is the distance in inches from the outboard edge of the wipe pattern to the windshield moulding at the left hand edge of the windshield. Wiper arms should be adjusted to conform to these specifications.

### 1971-72

Style	Dimension
"A" All Models	1.6 + 1.1 or -.5
"B" style 4-door station wagon & 4-door Notch Back sedans	2.00 + 1.50
"B" style 4-door Notch Back hardtop, 2-door Notch Back hardtop & 2-door convertible coupe	1.50 + 1.50
"C" style 4-door Notch Back hardtop & 2-door Notch Back hardtop	2.00 + 1.50
"E" style 2-door Notch Back hardtop & convertible coupe	1.50 + 1.50
"F" style	1.2 + 1.1 or -.5

### 1973-74

Style	Dimension
"A" 4-door hardtop & station wagon	1.75 + 1.50
"A" 2-door hardtop & El Camino	1.12 + 1.50
"B" 4-door station wagons & 4-door hardtop & sedan	2.00 + 1.50
"B" 4-door hardtop & 2-door hardtop, coupe, conv.	1.50 + 1.50
"C" 4-door hardtop, sedan & 2-door hardtop	2.00 + 1.50
"D" 4-door limousine	2.00 + 1.50
"E" 2-door hardtop & conv.	1.50 + 1.50
"F" All models	1.25 + 1.10 or -.5

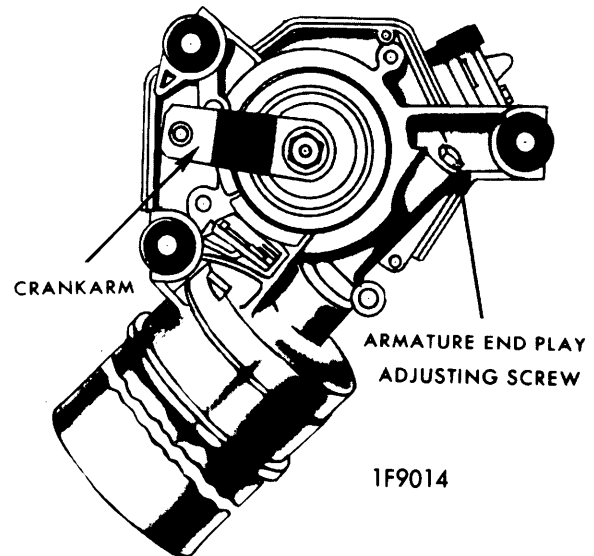

ARMATURE END PLAY ADJUSTMENT

## 1971-74 GENERAL MOTORS – ROUND MOTOR (Cont.)

**Wiper Motor Armature Adjustment** – Loosen adjusting screw locknut (see illustration) and turn adjusting screw as required until end of screw barely touches end of armature. Back off adjusting screw ¼ turn and tighten locknut.

### TROUBLE DIAGNOSIS - ON CAR (EXCEPT DEMAND SYSTEM)

- 1) If wiper inoperative or intermittent, check for: Open lead wire from motor terminal No. 1 to wiper switch. Wiper switch not securely mounted. Wiper switch defective.
- 2) If wiper will not shut off (goes full stroke), check for: Grounded lead wire from wiper terminal No. 1 to wiper switch. Corroded wiper terminals. Defective wiper switch.
- 3) If wiper will not shut off (blades move up and down about 15° from park), check for: Open in lead wire from wiper terminal No. 3 to wiper switch. Wiper switch mounting loose. Defective wiper switch.
- 4) If wiper operates at HI speed only, check for: Open lead wire from wiper terminal No. 3 to switch. Defective wiper switch.
- 5) If wiper operates at LO speed only, check for: Grounded lead from wiper terminal No. 3 to switch. Defective wiper switch.
- 6) (Cadillac only) – If wiper operates at HI with switch in MED position, check for: Open medium speed resistor.

### TROUBLE DIAGNOSIS - ON BENCH (EXCEPT DEMAND SYSTEM)

- 1) If wiper inoperative, check for: Open relay coil. Circuit breaker open. Armature open. Series field open. Brushes sticking. Defective solder joints. Binding condition at relay latch arm.
- 2) If wiper will not shut off (rotates through 360°), check for: Relay coil grounded. Relay latch spring disconnected or broken. Latch arm binding.
- 3) If wiper will not shut off (crankarm moves back and forth, with a loud "knock"), check for: Relay switch contacts shorting together. Drive pawl spring disconnected. Wiper has open shunt field and runs only at HI.
- 4) If wiper has only HI speed, check for: Shunt field open. Defective soldering at terminal No. 3 on terminal board.
- 5) If wiper has only LO speed, check for: Shunt field internally grounded. Shunt field lead to terminal board (black) grounded. Shorted armature.
- 6) If wiper has excessive speed in HI, and LO speed OK, check for: Open speed resistor. Poor resistor ground connection.
- 7) If wiper stops at random and does not return to full park, check for: Relay switch contacts dirty or broken.
- 8) If wiper operates intermittently, check for: Defective circuit breaker. Shorted armature or fields drawing excessive current causing circuit breaker to trip.

9) If wiper checks OK on bench but occasionally fails on car, check for: Armature end play tight. Gear Assembly end play tight. Loose solder or weld joints.

### TROUBLE DIAGNOSIS - WASHER SYSTEM (EXCEPT DEMAND SYSTEM)

Same procedure applies to GM "Round Motor" washer system as given for GM "Square Motor" wiper-washer system. See "General Motors Square Motor Wiper System" in this section.

### DEMAND SYSTEM TROUBLE DIAGNOSIS (ON CAR)

Check normal operation of wipers using instrument panel control switch. Check operation in all speeds and for correct shut-off and park. If wipers or washer pump do not operate correctly, refer to the following:

- 1) If wiper operates correctly with main control switch but does not start when shift lever switch is actuated in either detent, check for: Shift lever switch ground connection loose. Light blue wire to shift lever switch open. Shift lever switch defective.
- 2) If wiper is inoperative from either the control switch or shift lever switch, check for: Voltage at center terminal of motor. If no voltage, check for blown fuse or open circuit in feed wire. Light blue wire from wiper No. 1 terminal open. Wiper linkage locked or binding.
- 3) If wiper operates correctly from control switch but when shift lever switch is depressed to the first detent and released quickly, wiper blades start out of park position but return to park without making a full stroke, check for: Relay coil open. Relay switch contacts dirty or not closing. Holding contacts not closing. Yellow or orange leads not connected to relay, or poor solder connections.
- 4) If wipers will not shut off and blades operate through normal wipe pattern, check for: Holding switch contacts not opening. Wire between wiper terminal No. 1 and wiper control or shift lever switch grounded. Defective wiper control switch or shift lever switch. Wiper gear box relay coil grounded.
- 5) If wipers will not shut off and blades move up and down about 15° in and out of park, and operation is in HI only, check for: Wiper motor defective. Shunt field open. Wire between motor terminal No. 3 and wiper control switch open. Control switch defective.
- 6) If washer pump pumps continually when wiper is on, and wiper operates normally otherwise, check for: Dark blue wire between washer pump and control switches grounded. Defective wiper control switch. Washer pump defective. Pump ratchet wheel not being rotated by ratchet pawl.
- 7) If wipers have LO speed only, but shut off correctly, check for: Defective wiper control switch. Black wire from wiper terminal No. 3 to wiper control switch grounded. Wiper motor defective.
- 8) If operation is intermittent with main wiper switch on, check for: Loose wiper ground strap. Wiper control switch loose. Loose wiring connections. Defective wiper motor.

# Windshield Wipers

## 1971-74 GENERAL MOTORS - ROUND MOTOR (Cont.)

1971-74

Current Draw (Stall, Cold)

Lo Speed "F" Styles..... 18 Amps  
"A,B,C,D,E" Styles⓪ ..... 29 Amps

### Electrical Specifications (Round Motor)

Operating Voltage.....12 Volts

Current Draw (No Load Max.)

Lo Speed "F" Styles..... 5.0 Amps

"A,B,C,D,E" Styles⓪ ..... 6.0 Amps

Hi Speed "F" Styles..... 4.0 Amps

"A,B,C,D,E" Styles⓪ ..... 4.5 Amps

⓪ - Current draw for "A" Styles in 1971-72 is the same as "F" Styles shown.

### Wiper Motor Terminal Location (Round Motor)

No. 1 ..... Adjacent to gear box.

No. 2 ..... Center

No. 3 ..... Adjacent to motor.