

Windshield Wipers

1973-74 FORD MOTOR CO. ELECTRIC

DESCRIPTION & OPERATION

WIPER SYSTEM

Torino, Montego (Low Series), Pinto, Maverick, Mustang, Cougar, Comet – Windshield wipers are actuated by a permanent magnet, rotary type electric motor. Two wiper arms and blades are mounted on a pivot shaft, one at each side of windshield. Pivot shafts are connected to the motor by linkage arms and attaching clips.

Ford, Meteor, Mercury, Torino, Montego, Continental, Thunderbird, Mark IV – Wiper motor is a two speed permanent magnet depressed park type with brush end plate at one end of housing and a gear housing at the other end. The park switch is located in the gear cover and the park mechanism is located in the output arm.

INTERMITTENT WIPER GOVERNOR

All Models (Exc. Pinto, Maverick, Comet) – Intermittent operation of windshield wiper motor is controlled by a variable resistor in the windshield wiper control switch which, in conjunction with the electronic governor, allows a variable pause between wiping cycles. For intermittent operation the knob is rotated to the left. The more left rotation, the more resistance, thus more time between wipe cycles.

ADJUSTMENTS

ARM & BLADE ASSEMBLY

All Models – Remove arm and blade assemblies from pivot shafts. Turn on wiper switch, all pivot shafts to rotate three or four cycles. Turn off wipers, pivot shafts will now be in park position. Install arm and blade assemblies to the dimensions in the following table.

Model	Drivers Side	Right Side
Torino, Montego ^①	1/4 to 1 5/8"	0 to 1 3/8"
Torino, Montego ^②	^③ ±3/4"	0 to 1 1/2"
Maverick, Comet	1 1/2 to 2 1/2"	2 to 3"
Mustang, Cougar	1.60 to 1.90"	1.65 to 1.95"
Ford, Merc., Meteor	0 to 1.38"	0 to 1.38"
T-Bird, Mark IV	+1 to -1/4"	+1 to 1/4"
Continental	0 to 1.38"	0 to 1.38"
Pinto	2.38 to 3.38"	2.5 to 3.5"

- ① – Depressed Park
- ② – Non-Depressed Park
- ③ – About Top of Paint Line

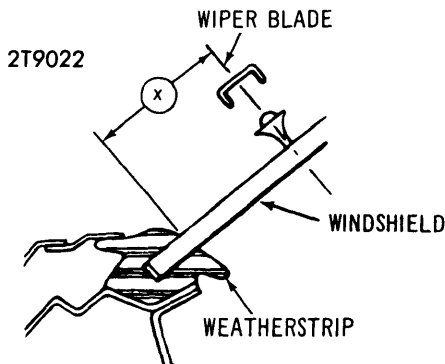

NON-DEPRESSED WIPER BLADE SETTING

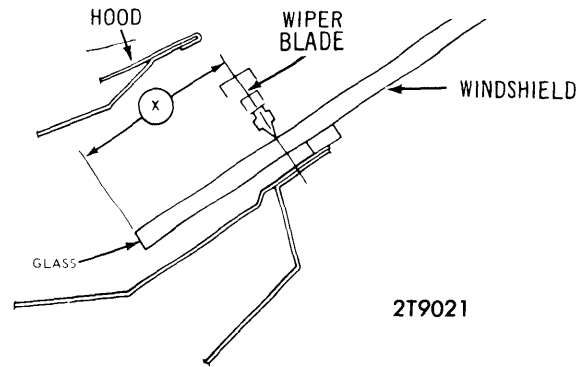

DEPRESSED WIPER BLADE SETTING

TESTING

WIPER MOTOR

Depressed Park – Connect ammeter as shown. Connect a jumper wire from battery negative post to low speed terminal on motor end plate and read current draw. Move jumper to high speed terminal and read current draw. In both cases current draw should not exceed 3.5 Amps.

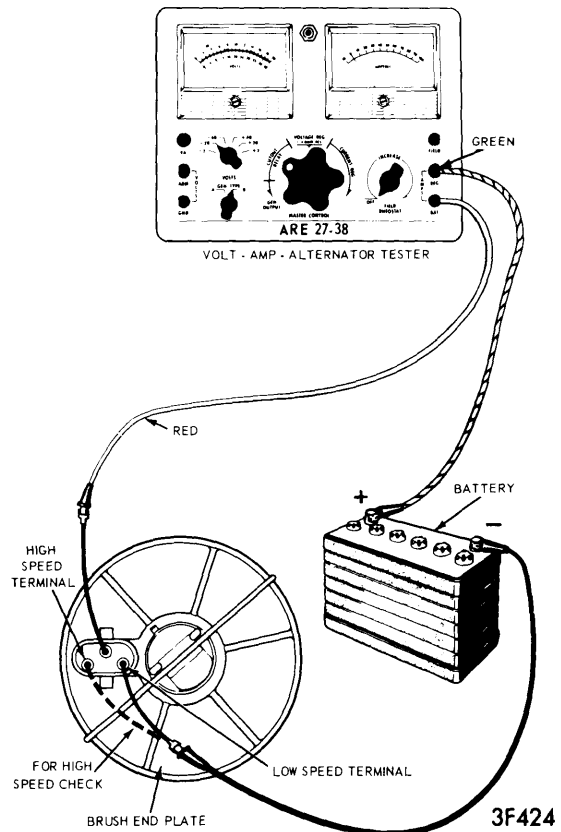

DEPRESSED MOTOR CURRENT DRAW TEST

1973-74 FORD MOTOR CO. ELECTRIC (Cont.)

Non-Depressed Park – Disconnect battery. Disconnect linkage from motor, and disconnect electrical plug to test motor on vehicle. Connect meter as shown. Current draw in high and low speed should not exceed 3 Amps.

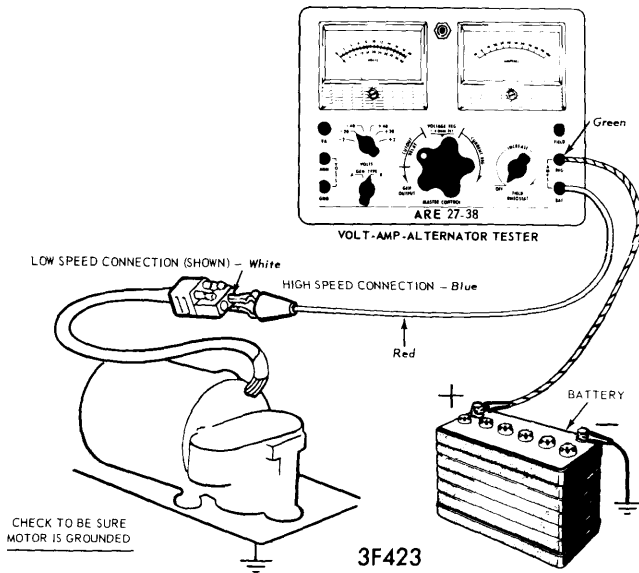

NON-DEPRESSED MOTOR CURRENT DRAW TEST

CIRCUIT BREAKER

All Models – Circuit breaker is located in wiper control switch, except on Ford, Mercury, Meteor which has a 8 1/4 Amp. circuit breaker in fuse panel. All rotary pin terminal switches have a circuit breaker rating of 8 1/4 Amps., and rotary blade terminal switches have a rating of 7 Amps.

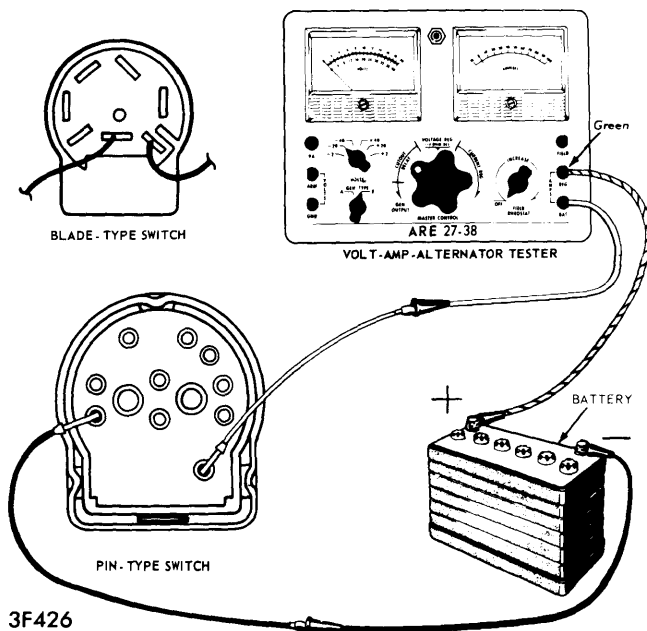

CIRCUIT BREAKER TEST

Before connecting leads, short them together and adjust current draw so that it equals circuit breaker rating. Connect meter as shown. Leave breaker connected to meter for ten minutes. Current reading should remain at rated current. If circuit breaker opens during the ten minutes it should be replaced.

Now adjust current draw to twice the rated current. The current reading on the ammeter should drop to zero within 30 seconds. If it takes longer than 30 seconds for breaker to open, it should be replaced.

WIPER SWITCH CONTINUITY TEST

All Models – Check continuity between switch terminals as shown in illustrations. Either a self powered test light or an ohmmeter can be used to test a standard switch. An ohmmeter must be used to test a switch used with the intermittent system. To detect marginal operation of the switch, rotate control knob while each reading is being taken. If switch does not exhibit continuity as shown or poor continuity exists, replace switch.

WIPER MOTOR PARKING TEST

Non-Depressed Park – Stop wiper system with ignition switch so blades are not in park position. Connect jumper wires as shown. The wipers should not run more than one full cycle then park. If motor will not park, or will not run to park, replace motor.

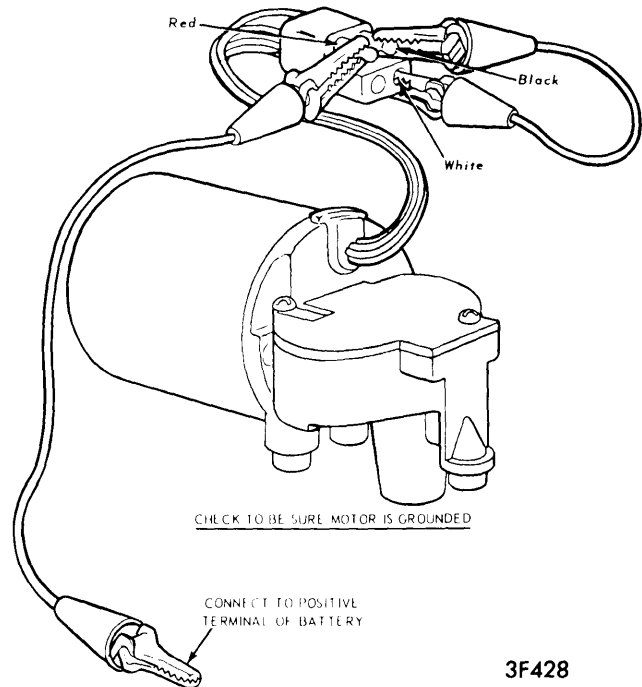

NON-DEPRESSED MOTOR PARK TEST

Depressed Park – Stop output arm about 90° past park position for this test. Make electrical connections (see illustration). With this hookup, the motor output arm should move in the following cycle: Rotate in normal direction. Reverse direction of rotation for about 10-15°. Stop rotating while

Windshield Wipers

1973-74 FORD MOTOR CO. ELECTRIC (Cont.)

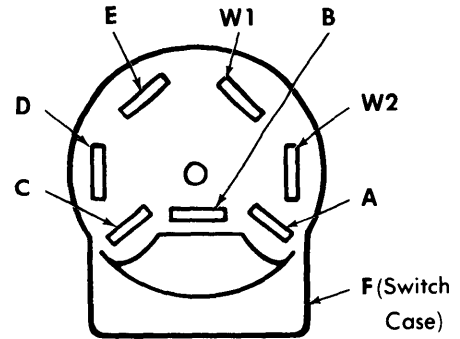
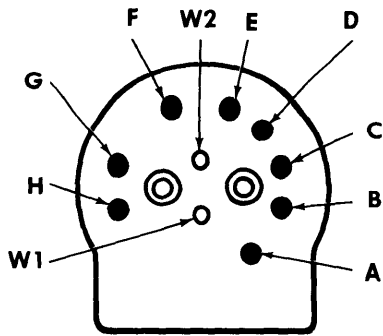

PIN-TYPE SWITCH

STANDARD EQUIPMENT (2 SPEED)

SWITCH POSITION	CONTINUITY BETWEEN TERMINALS
OFF (PARK)	B-C A-H F-G
LOW	C-D A-G-H
HIGH	D-E A-G-H
WASH	W1-W2

BLADE-TYPE SWITCH (2 SPEED)

SWITCH POSITION	CONTINUITY BETWEEN TERMINALS
OFF (PARK)	C-D A-B
LOW	A-B-C
HIGH	A-B-E
WASH	W1-W2

INTERMITTENT

SWITCH POSITION	CONTINUITY BETWEEN TERMINALS
OFF (PARK)	B-C A-H F-G
LOW	C-D-F-G A-H
HIGH	D-E-F-G A-H
INTERMITTENT	A-H C-D-F VARIABLE RESISTANCE BETWEEN F AND G-MIN. 100-900 ohms MAX. 5600-8400 ohms
WASH	W1-W2

INTERMITTENT

SWITCH POSITION	CONTINUITY BETWEEN TERMINALS
OFF (PARK)	A-B D-E
LOW	A-B D-E-F
HIGH	D-E-F A-B-C
INTERMITTENT	E-F A-B VARIABLE RESISTANCE BETWEEN D-E-MIN. 100-900 ohms MAX. 5600-8400 ohms
WASH	296-941

STANDARD SWITCH

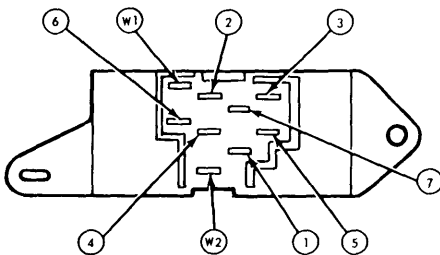

INTERMITTENT SWITCH

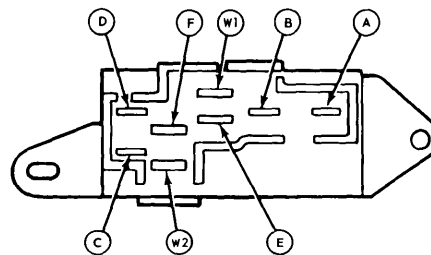

SWITCH POSITION	CONTINUITY BETWEEN TERMINALS
OFF	1-5, 3-7
LO	1-4, 2-7
HI	1-4, 2-6
WASH	W1-W2

* RESISTANCE BETWEEN TERMINALS F AND C VARIES FROM 500Ω ± 100 AT MIN. DWELL TO 10KΩ ± 20% AT MAX. DWELL

SWITCH POSITION	CONTINUITY BETWEEN TERMINALS
OFF	A-E
INT.	B-E-F, *
LO	B-E-F-C
HI	D-B-F-C
WASH	W1-W2

3F427

WIPER SWITCH CONTINUITY TESTS

1973-74 FORD MOTOR CO. ELECTRIC (Cont.)

crank pin is moved radially outward in a semicircular motion. Then finally stop in park position with current draw going to zero.

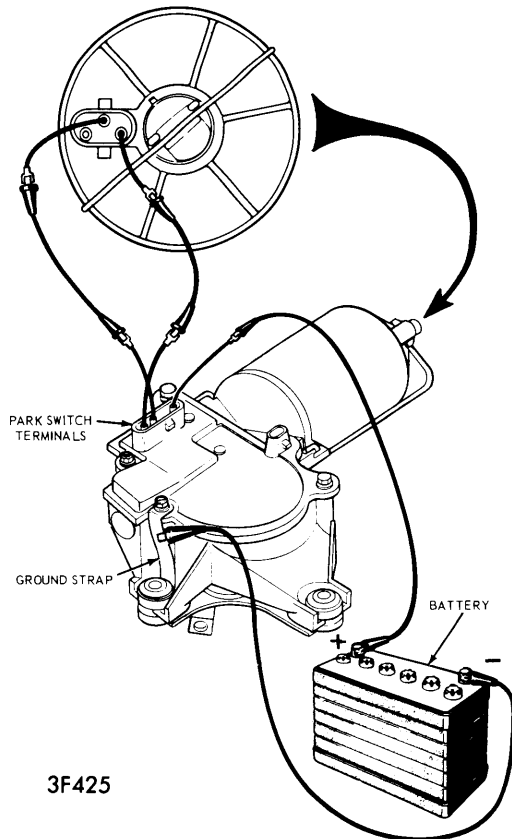

DEPRESSED MOTOR PARK TEST

If output arm rotates in the reverse direction more than 15°, or if the motor stalls or jams while the output arm is rotating in the reverse direction replace the arm and windlatch assembly with the appropriate kit. If the motor does not run or does not park, check wiring connections at motor before removing motor from vehicle. For any other deviation, replace the gear cover and switch assembly with appropriate kit.

COMPONENT REPLACEMENT

WIPER MOTOR

Ford, Mercury, Meteor, Torino, Montego, Continental, Thunderbird, Mark IV, (Depressed Park) – Disconnect battery. Remove wiper arm and blade assemblies. Remove left cowl screen for access through cowl opening. Disconnect linkage drive arm from motor output arm crankpin by removing retaining clip. From firewall, disconnect wire connectors from motor. Remove three bolts retaining motor to dash and remove motor. If output arm catches on dash during removal, hand turn clockwise so it will clear opening. Before installing motor, be sure output arm is in park position.

Maverick, Comet – On all models, wiper motor removal requires that the instrument cluster be removed first. If vehicle is equipped with A/C, the center connector and duct assembly will have to be removed for access to the wiper motor. With these items removed proceed as follows: Working through cluster opening disconnect the two pivot shaft links from motor drive arm by removing retainer clip. Disconnect wiring at motor. Remove three motor-to-motor mounting bracket bolts. Take motor out through cluster opening. To install, reverse removal procedure making sure that connecting clips are forced into lock position.

Montego, Torino, Maverick, Comet, Mustang, Cougar, (Non-Depressed Park) – Disconnect battery. Disconnect wiper motor wiring at connector. Remove cowl top left vent screen. Remove wiper link retaining clip from wiper motor arm. Remove wiper motor retaining bolts and remove wiper motor. To install, reverse removal procedure, making sure that connecting clips are forced to lock position.

Pinto – Disconnect wiper pivot shaft and link assembly from the motor drive arm ball. Remove three motor attaching screws and lower the motor away from under the left side of the instrument panel. Disconnect wiper motor harness, and remove wiper motor. To install, reverse removal procedure.

INTERMITTENT GOVERNOR

All Models – To remove governor on Montego, Torino, Thunderbird, Mark IV, it is necessary to remove instrument panel. The governor on Mustang, Cougar, and Lincoln Continental is mounted to the lower edge of instrument panel near wiper control. Once access is gained, remove connector plugs, retaining screws, and remove governor. To install, reverse removal procedure.