

Windshield Wipers

1973-74 AMERICAN MOTORS MODEL 16

DESCRIPTION

Wiper motor model 16 is a two speed permanent magnet depressed park type with brush end plate at one end of housing and a gear housing at the other end. Park switch is located in gear cover and park mechanism is located in output arm. As optional equipment, intermittent operation of wiper motor is controlled by a variable resistor in wiper switch in conjunction with an electronic governor. This allows for a variable pause between wiping cycles.

variable resistance between terminals "6" and "7" with an ohmmeter. This resistance controls governor operation for intermittent wipe operation.

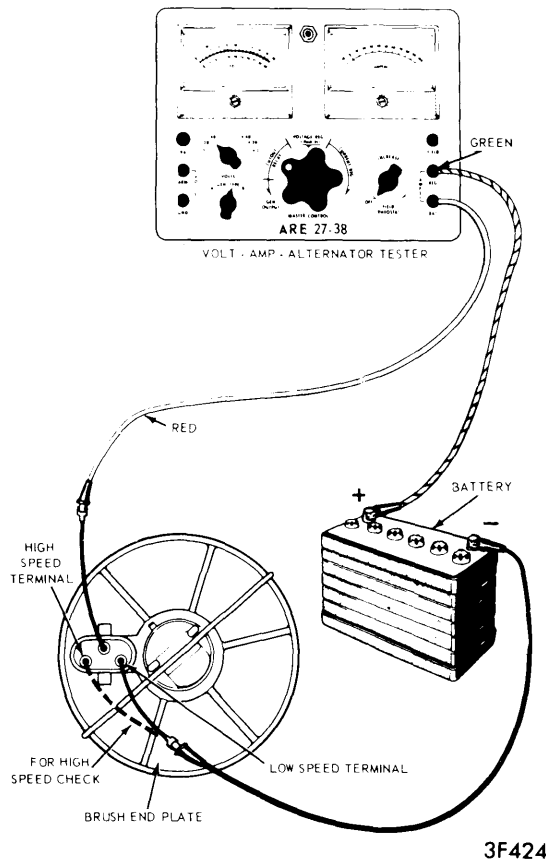

MOTOR CURRENT DRAW TEST

TESTING

WIPER MOTOR CURRENT DRAW

Perform test with motor on car and linkage disconnected or on bench. Connect ammeter (see illustration). Connect a jumper wire from battery to low speed terminal on motor end plate and read current draw. Move jumper to high speed terminal and read current draw. In both cases, current draw should not exceed 3.5 amps.

WIPER CONTROL SWITCH

Test wiper switch continuity using a test light or ohmmeter. Continuity should exist between different terminals at various switch positions (see illustration). Test intermittent switch

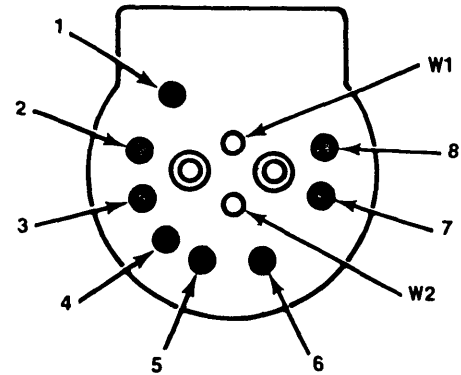

	SWITCH POSITION	CONTINUITY BETWEEN TERMINALS
STANDARD	OFF (PARK)	2-3 1-8 6-7
	LOW	3-4
	HIGH	1-7-8 4-5
	WASH	1-7-8
		W1-W2
INTERMITTENT	OFF (PARK)	2-3 1-8
	LOW	3-4-6-7 1-8
	HIGH	4-5-6-7 1-8
	INTERMITTENT*	1-8
	WASH	3-4-6 W1-W2

*Variable resistance between 6 and 7 - MIN. 100-900 ohms - MAX. 5600-8400 ohms.

4AM01

WIPER SWITCH CONTINUITY TEST

WIPER MOTOR PARK TEST

Operate motor and stop motor when output arm is about 90° past park position for this test. With jumper wires connected as shown in illustration, the motor output arm should move in following cycle: Rotate in normal direction, then reverse rotation for about 10-15°, and stop rotation while crank arm is moved outward in a semicircular motion. Then finally stop in park position with current draw reducing to zero.

Windshield Wipers

1973-74 AMERICAN MOTORS MODEL 16 (Cont.)

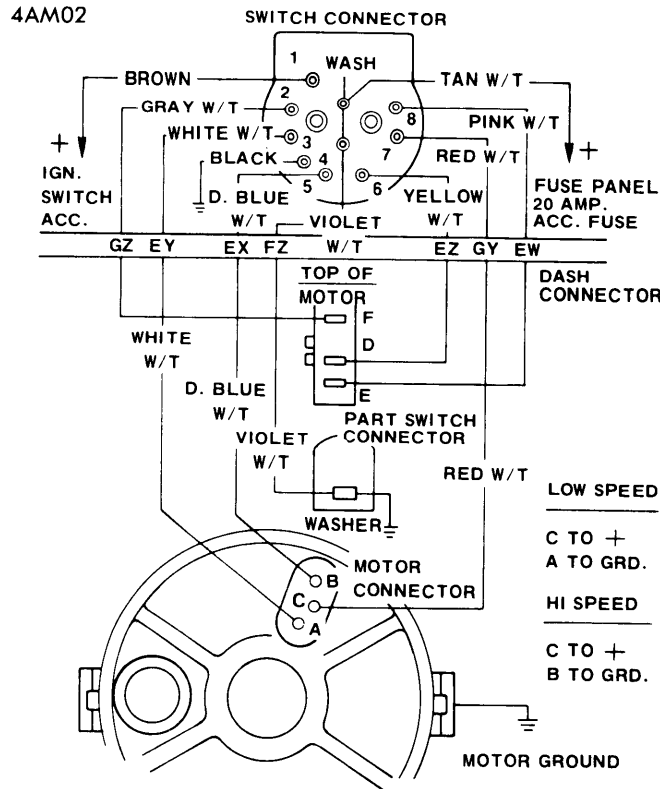

WIPER WIRING DIAGRAM TYPICAL

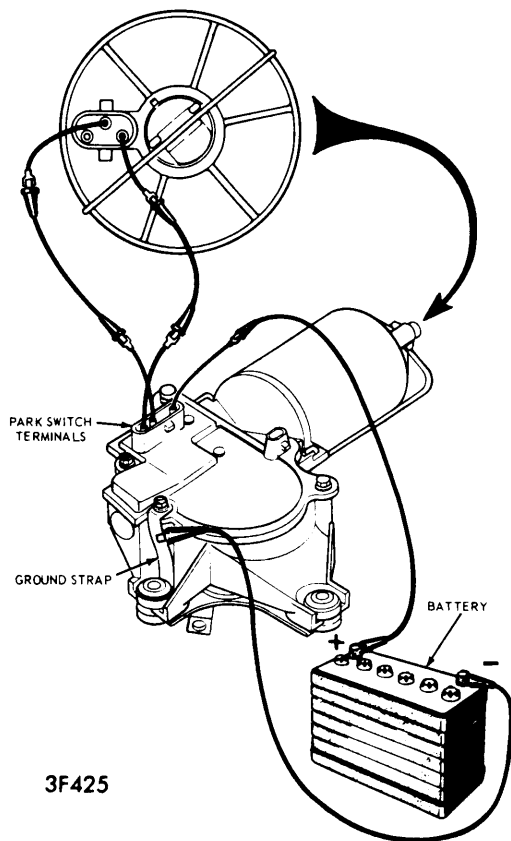

MOTOR PARK TEST

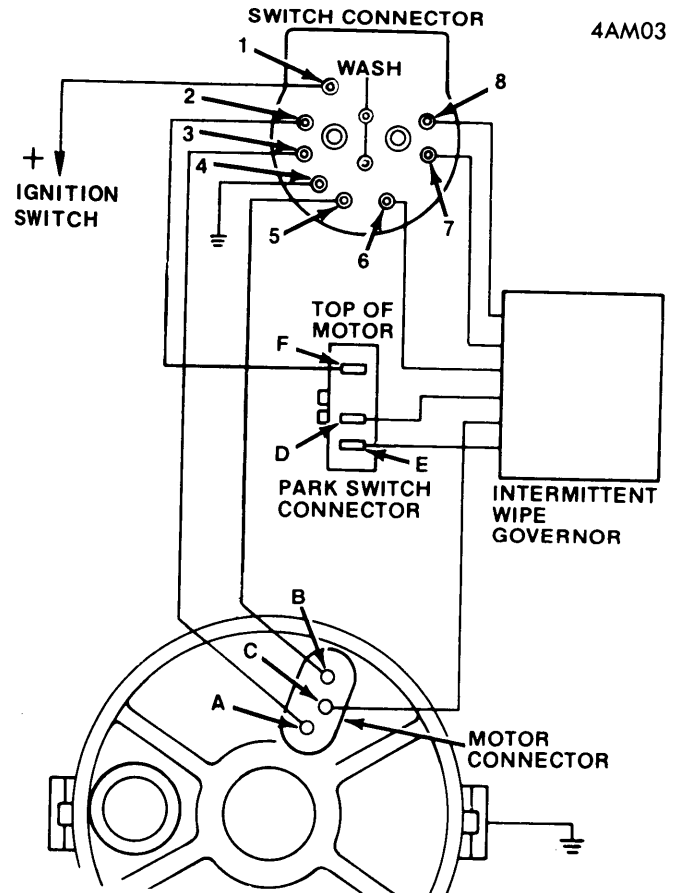

WIPER WIRING DIAGRAM WITH GOVERNOR