

1972-74 FORD MOTOR CO. HEADLIGHT DOORS

Continental Mark IV
Lincoln Continental
Mercury

DESCRIPTION

Headlight covers are actuated by one vacuum motor on Continental Mark IV, and two vacuum motors on Lincoln and Mercury. Vacuum is directed to motor(s) by a vacuum distribution valve integral with headlight switch. A reserve vacuum reservoir provides limited headlight cover cycling without engine operating. A check valve is used in vacuum source line to prevent vacuum leakage from reservoir back to engine. Springs are used on all models to automatically open covers in event of vacuum system failure. If headlight covers will not open automatically, a by-pass valve is provided to vent system and allow covers to open.

OPERATION

Pulling out headlight switch knob actuates the distribution valve on back of switch. Vacuum is then applied to vacuum motor(s), opening headlight covers. Distribution valve also provides a vacuum relief (exhaust) port to side of motor diaphragm without vacuum. When headlight switch is pushed in, vacuum supply and relief ports are reversed and headlight covers close. The reserve vacuum reservoir provides vacuum storage for limited headlight cover cycling. A reservoir check valve is used to prevent vacuum leakage back to engine and is located integral with vacuum manifold on Lincoln Continental models. For other models, check valve is located in vacuum supply line. Headlight covers on Continental Mark IV models have a spring attached to each cover for opening covers in event of vacuum failure. On Mercury and Lincoln models, spring is built into each motor. Vacuum applied to vacuum motor(s) during closing overcomes spring tension. A by-pass valve is located in vacuum lines between headlight switch and vacuum motor(s). By-pass valve vents system to allow covers to open if covers will not open automatically. *NOTE — If engine has been shut down long enough to allow a normal leakdown in vacuum system (overnight), springs will open headlight covers.*

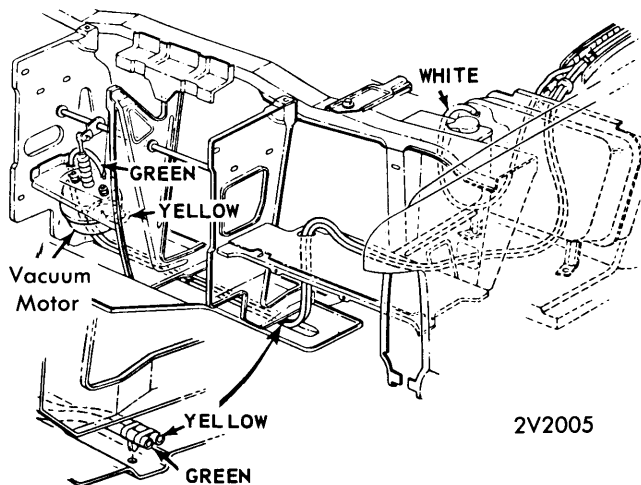

CONTINENTAL MARK IV VACUUM SYSTEM

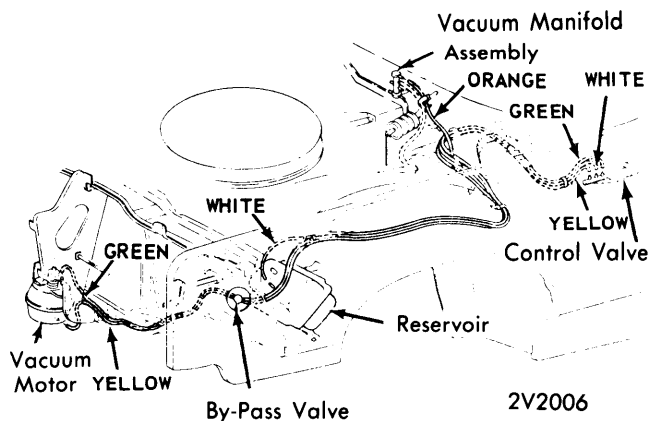

LINCOLN CONTINENTAL & MERCURY VACUUM SYSTEM (TYPICAL)

TESTING

A leak test on any part or component of vacuum system can be accomplished with the use of a vacuum test probe. Plug probe into system at desired point. The reading on the gauge should momentarily fall below 14" of vacuum, if there are no leaks in the system the reading should come back to 14" of vacuum and hold steady. To leak test headlight switch, attach vacuum probe to center (white) port, and cap the two outside ports. Move selector switch thru OFF-PART-ON positions and observe the gauge. The gauge readings should be 14" in all positions, if reading should fall off in any position switch should be replaced.

REMOVAL & INSTALLATION

VACUUM MOTOR

Disconnect vacuum hoses from cover motor. Disconnect clip retaining motor control rod to headlight cover outer shaft assembly and remove rod from shaft. Remove nuts retaining motor assembly to motor support, and remove motor thru opening at bottom of vehicle. To install, reverse removal procedure, noting that hose with green stripe goes to top of motor and hose with yellow stripe on bottom.

VACUUM RESERVOIR

Raise left front of vehicle and remove left front tire and wheel assembly. From under fender, remove retaining nuts from vacuum reservoir, and vacuum hoses, and remove vacuum reservoir. To install reverse removal procedure.