

## 1974 GENERAL MOTORS TWILIGHT SENTINEL

**Buick  
Cadillac**

### DESCRIPTION

System automatically controls on-off operation of headlights, tail lights and instrument panel lights in response to amount of daylight in which car is being operated. A time delay control allows lights to remain on for a preselected period after ignition is turned off. Component location differs on individual car models as follows:

**Buick** – Photocell assembly is mounted with the sensitive surface facing up to obtain an unobstructed view of skylight through the windshield. Mounting location is adjacent to the radio front left-hand speaker grille or left defroster opening. The amplifier unit is mounted on the lower instrument panel to right of steering column. The time delay and on-off switch is attached to rear of regular light switch.

**Cadillac** – Photocell assembly is mounted with sensitive surface face up. Mounting location is under the left front speaker grille. The amplifier is mounted on the lower instrument panel brace. The time delay and on-off switch control is attached to rear of the regular light switch.

### OPERATION

#### AUTOMATIC

1) Twilight Sentinel system will operate automatically when the ignition switch is on, the headlight switch is off and the control ring pointer is turned on (any position on the dial counterclockwise from "Off" position). The system will automatically turn lights on when daylight reduces to the point at which road illumination becomes necessary for safe driving. As daylight increases in the morning to the point at which road illumination is no longer necessary, it will turn lights off. The system is designed so lights will not go on or off when there are sudden changes in lighting such as going through tunnels, passing under bright lights, etc. This is accomplished by a 10-60 second delay before amplifier switch system either on or off.

2) A variable time-delay switch control permits driver to select a delay period of from a few seconds to a maximum of 1½-4½ minutes for headlights to go off after ignition switch is turned off. Additional lighting may be provided (during this period) by turning on cornering lights (if equipped). All lights will turn off automatically at end of time-delay period selected by driver.

#### MANUAL

Manual operation of lights can be obtained by rotating time-delay control knob to OFF position. This disables twilight sentinel by disconnecting ground circuit. Lights will now operate only by use of regular light switch.

### TESTING & DIAGNOSIS

Make sure time-delay control is in ON position, photocell is not obstructed, lighting system operates correctly manually, manual headlight switch is OFF, and that fuses are not blown.

#### CHECKING PROCEDURE

**Buick** – Follow procedures in sequence listed.

1) With light and ignition switches "Off" and Sentinel "On", cover photocell and turn ignition on. Lights should turn on within 10 seconds.

2) Remove cover from photocell and shine bright light (flashlight) on photocell. Lights should turn off within 10-60 seconds.

3) Cover photocell again and allow time (10-60seconds) for lights to turn on. Turn ignition switch off and lights should remain on for 1½ -4½ minutes and then turn off.

4) With ignition off and key removed (to prevent ignition buzzer from sounding), turn regular light switch to park or headlight position. Open a door and warning buzzer should sound.

5) Satisfactory performance of tests 1 through 4 indicates unit is operating properly. If unit is operating properly but turn on time is incorrect, make minor Sensitivity Adjustment.

**Cadillac** – Follow procedures in sequence listed.

1) With headlight switch in "Off" position, adjust Twilight Sentinel control ring midway between "Off" and "Max". Hold a lighted flashlight or trouble light directly over photocell. Turn ignition switch to "On" position. Headlights and taillights should remain off.

2) Remove light and cover photocell with a heavy dark cloth. Headlights and taillights should turn on within one minute.

3) With photocell covered and ignition switch in "On" position, allow 10-60 seconds for lights to turn on. Turn ignition switch to "Off" position. Headlights and taillights should turn off within three minutes.

4) With ignition switch in "Off" position and key removed (to prevent ignition buzzer from sounding), turn regular light switch to park or headlight position. Open a door and warning buzzer should sound.

5) Satisfactory performance of tests 1 through 4 indicates unit is working properly. If unit is operating properly but turn on time is incorrect, make minor Sensitivity Adjustment.

### SENSITIVITY ADJUSTMENT

If a photocell or amplifier is malfunctioning, both must be replaced as a matched set since no provision is made for adjusting a mismatched set. However, if the turn-on or turn-off time is not correct a recommended procedure to advance or retard turn-on time by 15 minutes follows:

#### TROUBLE SHOOTING

##### HEADLIGHTS TURN ON TOO LATE IN EVENING OR OFF TOO EARLY IN MORNING

With ignition and headlight switch turned off, cover photocell so no light strikes it. Take a resistance reading between Black and Purple wires on Buick or Black/Yellow and Light Green wires on Cadillac amplifier connector. Now adjust control screw (see illustration) until resistance reads one-half of that obtained above. If amplifier has been previously adjusted, set resistance value to 4100-4500 ohms.

##### HEADLIGHTS TURN ON TOO EARLY IN EVENING OR OFF TOO LATE IN MORNING

Follow same procedure as above, turning screw clockwise until resistance is one and one-half times original reading.

# Headlights

## 1974 GENERAL MOTORS TWILIGHT SENTINEL (Cont.)

Sensitivity Adjustment Control Screw

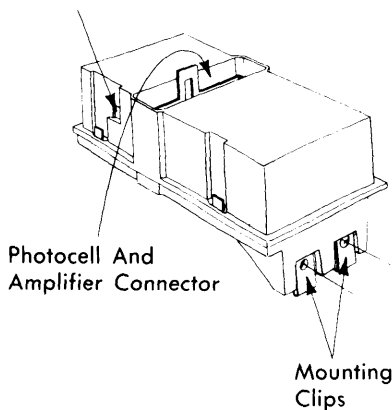

4BU01

### SENSITIVITY ADJUSTMENT CONTROL SCREW

link and light switch. Inoperative light switch (circuit breaker). Open ground path through on-off switch of time delay control assembly. Inoperative photocell or amplifier.

### LIGHTS WILL NOT TURN OFF IN DAYLIGHT

Amplifier Sensitivity control maladjusted. Missing photocell, poor contact between photocell and socket, or socket assembly fallen out of mounting hole. Inoperative photocell or amplifier.

### LIGHTS WILL NOT TURN OFF AFTER IGNITION IS OFF

Ignition line not at ground potential in off position. Inoperative time delay control assembly. Open wiring in circuit. Inoperative amplifier.

### LIGHTS WILL NOT STAY ON FOR 1 1/2 - 4 1/2 MINUTES AFTER IGNITION IS OFF

Inoperative time delay control assembly. Blown taillight fuse. Improper resistance at amplifier connector. Short in wiring circuit. Inoperative amplifier.

### LIGHTS WILL NOT TURN ON IN DARKNESS

Improper alignment of wiring harness connector at amplifier. Loose connection at light switch. Open wiring between fusible

### WARNING BUZZER WILL NOT OPERATE

Open wiring in buzzer circuit. Inoperative door jam switch. Bad connection at light switch. Inoperative amplifier.

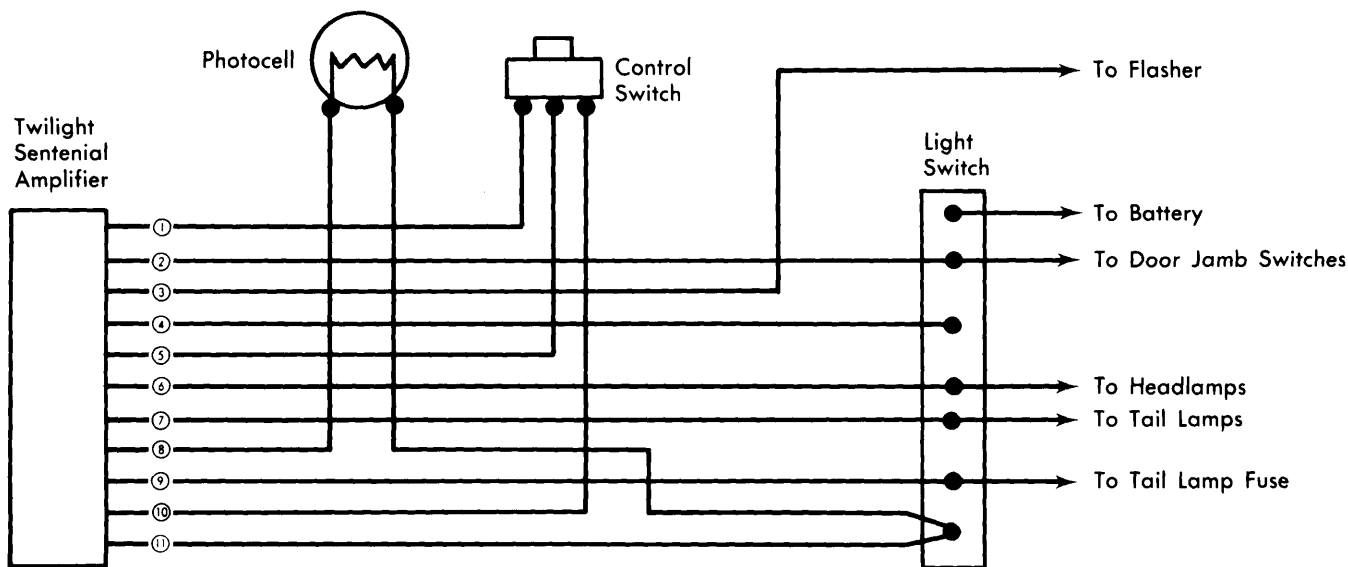

4GMA02

#### BUICK

- ① - Black-Yellow
- ② - White
- ③ - Black-White
- ④ - Orange
- ⑤ - Lt. Green
- ⑥ - Lt. Blue
- ⑦ - Dk. Green-White
- ⑧ - Black
- ⑨ - Brown-White
- ⑩ - Purple
- ⑪ - Red

#### CADILLAC

- ① - White
- ② - Black-Yellow
- ③ - Purple
- ④ - Lt. Green
- ⑤ - Black-Yellow
- ⑥ - Orange
- ⑦ - White
- ⑧ - Lt. Blue
- ⑨ - Red
- ⑩ - Brown-White
- ⑪ - Dk. Green-White

### GENERAL MOTORS TWILIGHT SENTINEL CIRCUIT