

1973 DODGE

STOP LIGHT SWITCH

Switch is located on brake pedal bracket.

SPEEDOMETER & GAUGES

Speedometer and all instruments can be removed or serviced after instrument cluster has been removed.

PRINTED CIRCUIT BOARD

Can be serviced after instrument cluster has been removed.

INSTRUMENT CLUSTER REMOVAL

Dart — Disconnect battery ground cable. Tape steering column to prevent scratching surface. Remove Air Cond. outlet (if equipped). Remove four screws retaining steering column cover and remove cover. Lower steering column and remove speedometer cable. Remove six cluster retaining screws, and bring cluster out far enough to disconnect printed circuit board and remove cluster.

Challenger — Disconnect battery ground cable. Remove lamp panel mounting screws, slide panel out and lay on top of instrument panel. It is not necessary to disconnect harness to lamp panel. Remove switch bezel mounting screws and let bezel hang loose. It is not necessary to disconnect switches. Remove steering column plate mounting screws and column support clamp retainer nuts. Allow column to rest on seat. Disconnect speedometer cable. Remove cluster bezel mounting screws, angle bezel out so that it clears clock reset button. Reach between bezel and panel and disconnect stereo wiring harness (if so equipped). *NOTE — On Rallye cluster, clock reset knob and odometer reset knob must be removed from cluster bezel to remove clock.* Remove cluster to panel mounting screws. Disconnect wiring harness and remove cluster.

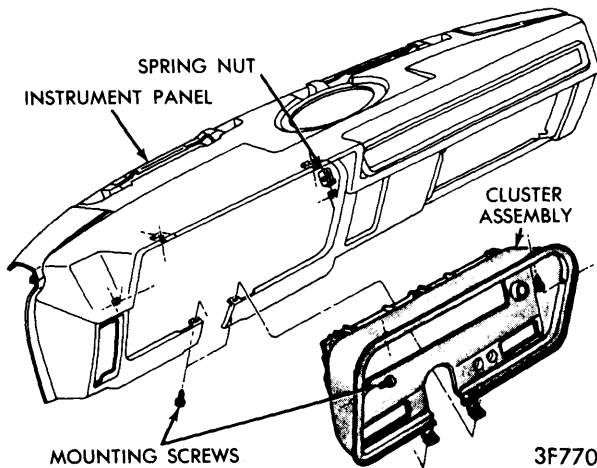

CORONET, CHARGER INSTRUMENT CLUSTER REMOVAL

Charger, Coronet — Disconnect battery cable. Remove radio, and all electrical leads and lamps on right rear of cluster. Remove speedometer cable and heater control support from rear of cluster. Remove other two heater control screws and let control hang. Tape steering column to prevent scratching surface and lower column. Remove six cluster retaining screws and tip cluster out at top. Disconnect all remaining electrical connections and lamps and remove cluster.

Polara, Monaco — Disconnect battery cable. Tape steering column to prevent scratching surface. Remove screws retaining lamp panel and remove panel. Remove hood release handle. Remove retaining screws holding column cover and remove cover. Remove plastic rib that holds vent control cable. Remove retaining clip and cable thru column cover opening. Remove Air Cond. center duct (if equipped). Lower steering column and remove speedometer cable. Remove two hidden screws under cluster bezel, one from top and one from side and remove radio bezel. Remove cluster bezel retaining screws and tip down far enough to remove all remaining electrical connections and lamps. Remove cluster bezel from panel. Remove four cluster assembly screws and remove cluster.

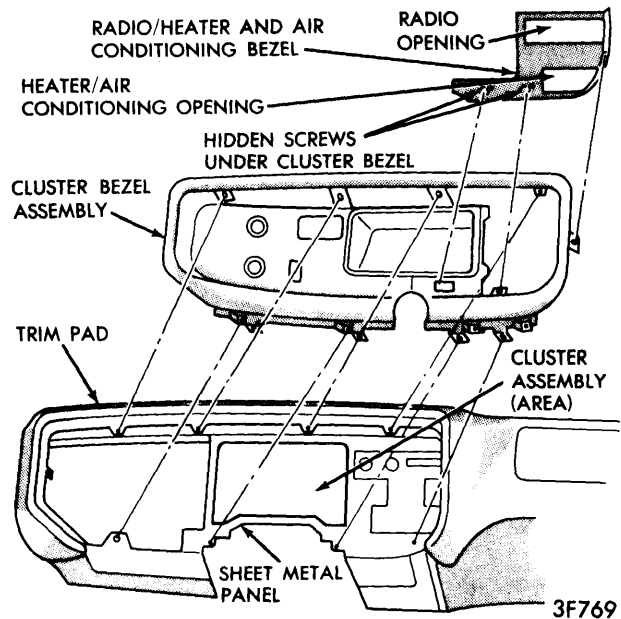

POLARA, MONACO INSTRUMENT CLUSTER REMOVAL

1973 PLYMOUTH

STOP LIGHT SWITCH

Switch is located on brake pedal bracket.

SPEEDOMETER & GAUGES

Speedometer and all instruments can be removed or serviced after instrument cluster has been removed.

PRINTED CIRCUIT BOARD

Can be serviced after instrument cluster has been removed.

INSTRUMENT CLUSTER REMOVAL

Valiant — Disconnect battery ground cable. Tape steering column to prevent scratching surface. Remove air cond. outlet (if equipped). Remove four screws retaining steering column cover and remove cover. Lower steering column and remove speedometer cable. Remove six cluster retaining screws, and bring cluster out far enough to disconnect printed circuit board, remove cluster.

Barracuda — Disconnect battery ground cable. Remove lamp panel mounting screws, slide panel out and lay on top of instrument panel. It is not necessary to disconnect harness to lamp panel. Remove switch bezel mounting screws and let bezel hang loose. It is not necessary to disconnect switches. Remove steering column plate mounting screws and column support clamp retainer nuts. Allow column to rest on seat. Disconnect speedometer cable. Remove cluster bezel mounting screws, angle bezel out so that it clears clock reset button. Reach between bezel and panel and disconnect stereo wiring

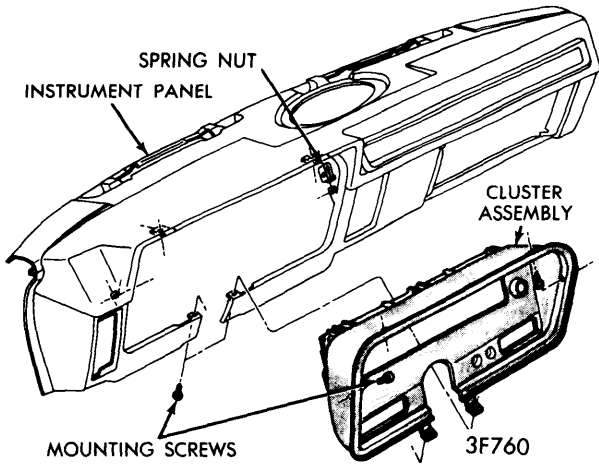

SATELLITE INSTRUMENT CLUSTER REMOVAL

harness (if so equipped). *NOTE* — On Rallye cluster, clock reset knob and odometer reset knob must be removed from cluster bezel to remove clock. Remove cluster to panel mounting screws. Disconnect wiring harness and remove cluster.

Satellite — Disconnect battery ground cable. Remove radio and all electrical leads and lamps on right rear of cluster. Remove speedometer cable and heater control support from rear of cluster. Remove other two heater control screws and let control hang. Tape steering column to prevent scratching surface and lower column. Remove six cluster retaining screws and tip cluster out at top. Disconnect all remaining electrical connections and lamps and remove cluster.

Fury — Disconnect battery ground cable. Tape steering column to prevent scratching surface. Remove screws retaining lamp panel and remove panel. Remove hood release handle. Remove retaining screws holding column cover and remove cover. Remove plastic rib that holds vent control cable. Remove retaining clip and cable (thru column cover opening). Remove air cond. center duct (if equipped). Lower steering column and remove speedometer cable. Remove two hidden screws under cluster bezel, one from top and one from side and remove radio bezel. Remove cluster bezel retaining screws and tip down far enough to remove all remaining electrical connections and lamps. Remove cluster bezel from panel. Remove four cluster assembly screws and remove cluster.

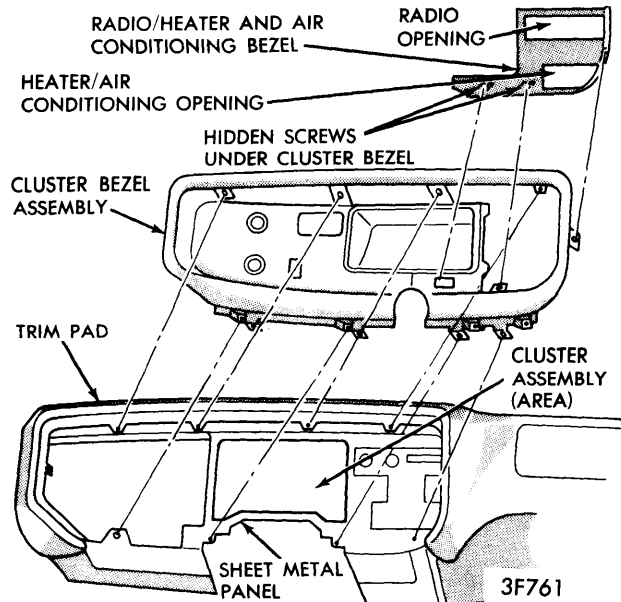

FURY INSTRUMENT CLUSTER REMOVAL