

4-114 Switches, Gauges & Speedometer

1974 CHEVROLET

CLUTCH START SWITCH

Vehicles with manual transmissions use a clutch start switch which prevents engine start unless the clutch pedal is depressed. The switch mounts on clutch pedal bracket.

All Models (Exc. Corvette) – To remove switch, unplug electrical connector from switch, compress actuating shaft retainer and disconnect shaft from clutch pedal. Remove switch and/or bracket for service as required. To install switch, reverse removal procedure, no adjustment is necessary.

Corvette – To remove switch, unplug electrical connector from switch. Remove retainer from link on clutch pedal arm. Remove screw fastening switch to pedal support and lift off switch. To install, reverse removal procedure.

HEADLIGHT SWITCH

Chevrolet & Nova – Disconnect battery. Place control knob in "ON" position. From under instrument panel release switch shaft retainer, pull knob and shaft assembly out. Remove ferrule nut and lift out switch assembly. Disconnect plug from light switch. To install, reverse removal procedure.

Chevelle & Monte Carlo – Disconnect battery. Remove instrument panel pad. Remove left radio speaker and pull switch control knob to "ON" position. From behind instrument panel release switch shaft retainer and remove shaft assembly. Remove ferrule nut and lift out switch assembly. To install, reverse removal procedure.

Camaro – Disconnect battery. Remove steering column lower cover (6 screws). Reach up under panel and depress switch shaft retainer, while pulling on shaft. Remove nut securing switch to carrier. Remove cluster carrier (4) screws in front, (2) screws from back of cluster lower edge (either side of steering column) and tilt right side of cluster out. *NOTE* – Grounding ring at cigar lighter housing may have to be freed for further movement of cluster carrier. Unplug connector from lighting switch and remove switch. To install, reverse removal procedure.

Corvette – Disconnect battery. Remove screws securing mast jacket trim covers, remove covers for access. Unclip and remove left side console forward trim panel so that left side instrument cluster may be lowered for access to switch. Lower

steering column. Remove screws and washers securing left instrument panel to door opening, top of dash and left side of center instrument panel. Pull cluster assembly down and then tip forward for access to switch. Depress switch shaft retainer and remove knob and shaft assembly. Remove switch retaining bezel. Disconnect vacuum hoses from switch (mark for reassembly). Pry connector from switch and remove switch. To install, reverse removal procedure.

INSTRUMENT CLUSTER

Nova – Disconnect battery. Lower steering column. Remove 3 screws above front of heater control securing it to cluster. Remove radio control knobs, washers, bezel nuts and front support at lower edge of cluster (allows radio to remain in panel). Remove screws at top, bottom and sides of cluster. Tilt console forward and reach behind to disconnect speedometer cable, speedminder and electrical plug connectors. After removing screws, lift cluster out of carrier. To install, reverse removal procedure.

Camaro – Disconnect battery. Remove 6 screws (2 above ash tray) securing trim cover beneath steering column. Reach under cluster left side and depress headlamp switch shaft retainer button, while pulling on switch knob. Remove headlamp switch retaining nut. Remove cigar lighter and housing. From rear of panel remove screw on either side of steering column. Remove 4 screws on front of carrier and one screw retaining ground wire for wiper switch. Tilt carrier out (for access) and remove connector plugs on wiper and headlamp switches. Remove 8 screws securing cluster lens and 4 screws securing cluster. Disconnect PRNDL indicator from steering column. Reach behind cluster, depress speedometer cable housing tang on rear of cluster then tilt cluster forward. Remove connectors from printed circuit and clock then free harness from retainer clips. Remove cluster. To install, reverse removal procedure.

Chevrolet – Disconnect battery. Remove cigar knob and remove hidden screw (where knob was). Pull headlamp switch ON, then remove hidden screw above middle of shaft. Remove 2 screws at bottom corners of shroud and lift off shroud.

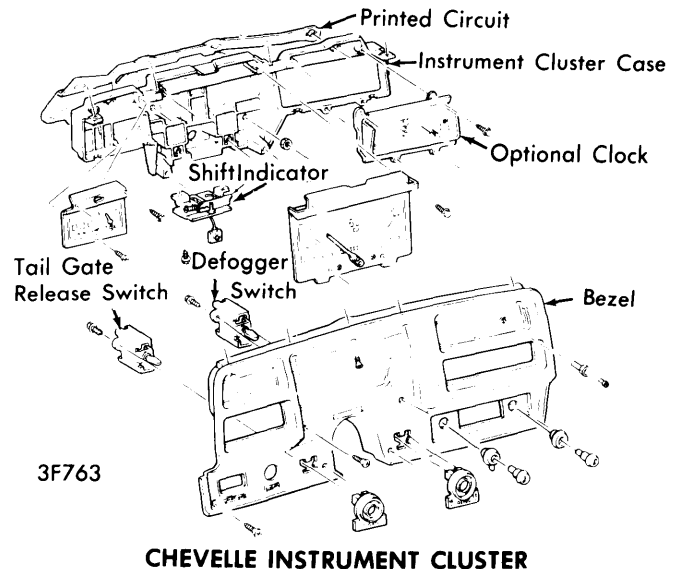
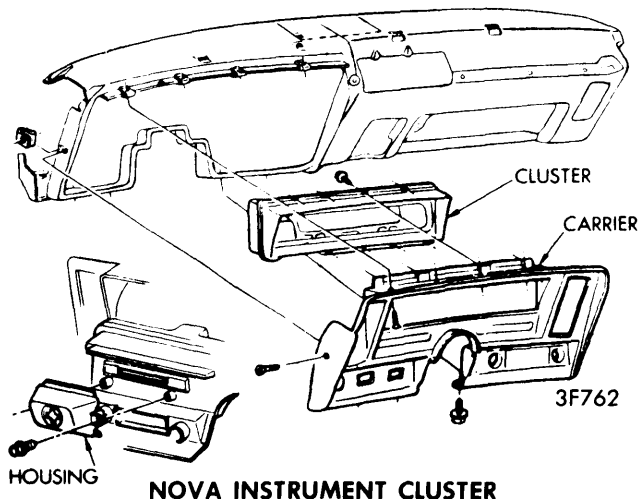

Switches, Gauges & Speedometer 4-115

1974 CHEVROLET (Cont.)

Chevelle (Std.) – Disconnect battery. Remove radio and clock stem knobs. Remove instrument bezel retaining screws. Pull bezel out and disconnect tailgate release, (Station Wagon), or defogger switch. Remove retaining screws to speedometer head and lift head out. Remove clock mounting screws and lift out clock. Disconnect transmission shift indicator cable from steering column. Disconnect wiring and speedometer cable. Remove instrument cluster case. Remove fuel gauge and transmission shift indicator.

Monte Carlo & Chevelle SS – Disconnect battery ground. Remove radio knobs and clock set knob. Remove instrument bezel retaining screws and pull bezel out. Disconnect rear window defogger switch (if equipped). Remove speedometer retaining screws and speedometer. Remove gauges for service as required. To install bezel, reverse removal procedure.

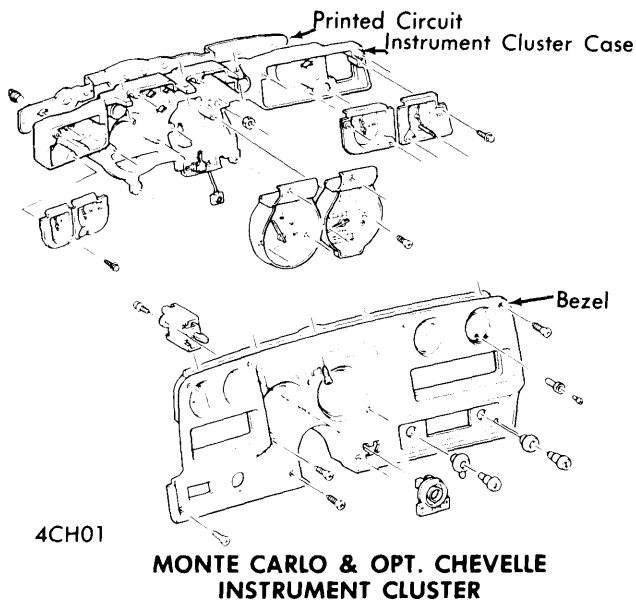

Corvette (Left Side) – Disconnect battery. Lower steering column. Remove screws and washers securing left instrument panel to door opening, top of dash and left side of center instrument panel. Unclip and remove floor console left forward trim panel. Pull cluster assembly slightly forward (for access). Remove speedometer cable housing nut, tachometer cable housing nut, headlight and ignition switch connectors and instrument lamps. To install, reverse removal procedure.

Corvette (Center Section) – Disconnect battery. Remove wiper switch trim plate screws, tip plate forward and remove connector. Lift trim plate out from cluster assembly. Unclip and remove right and left console forward trim pads. Remove nuts from studs at lower edge of cluster. Remove remaining screws retaining cluster assembly to instrument panel. Remove right instrument panel pad. Remove radio knobs, bezel retaining nuts and one radio support bolt (behind cluster assembly). Slide radio back towards firewall and pull cluster forward. Reach behind cluster, disconnect oil pressure line, wiring harness and bulbs. **CAUTION** – Center cluster trim plate is designed to collapse under impact. Do not pry cluster plate forward to gain access. Lift cluster assembly up and forward for removal. To install, reverse removal procedure.

