

4-108 Switches, Gauges & Speedometer

1974 BUICK

CAUTION — If equipped with Air Cushion Restraint System, turn ignition key to lock, disconnect battery ground cable and tape end before servicing instrument panel components. This must be done to prevent accidental release of A.C.R.S.

HEADLIGHT SWITCH REMOVAL

Century, Century Luxus, Regal — Pull switch out to last notch, depress latch button and pull knob and rod assembly from switch. **NOTE** — On air conditioned models, first remove left duct by removing two screws and two hose clamps. Remove switch escutcheon, pull switch down as far as possible and unplug from connector.

All Other Models — Pull switch out to last notch, depress spring-loaded latch button on switch, while pulling knob and rod assembly out of switch. Remove escutcheon, then remove left trim panel. Remove switch retainer nut and pull switch down and remove from connector.

CLUTCH START SWITCH

Apollo models with manual transmissions have a clutch start switch located on right side of pedal bracket. Purpose of switch is to prevent engine start while in gear with clutch pedal not depressed.

STOP LIGHT SWITCH

Mechanical type mounted on brake pedal bracket. Adjust Apollo stop light switch so stop lights come on when brake pedal is depressed .38 to .64" measured at pad. Adjust all other models as follows: With brake pedal fully depressed, push switch and valve forward until they stop against bracket or arm. Pull pedal rearward with 15 to 20 pounds force to properly adjust switch.

CENTURY, CENTURY LUXUS & REGAL SERIES

INSTRUMENT PANEL & CLUSTER REMOVAL

Disconnect battery ground cable and tape end. Remove glove box door, glove box, and right trim plate. Remove four instrument panel housing-to-cover screws. Disconnect front speaker

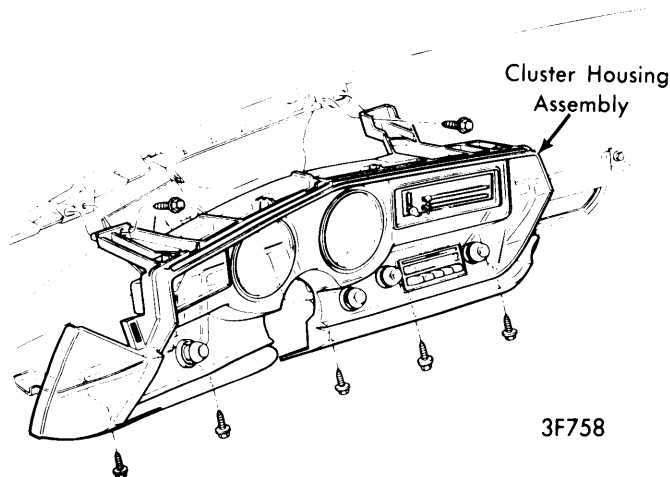

CENTURY, REGAL INSTRUMENT PANEL

connector from radio. Pull instrument panel cover rearward on left side to disengage retaining clips. On right side, cover must be pulled downward while pulling rearward. Pry cluster trim plate from panel if equipped. Disconnect heater-air conditioning cables and connections from control head. Disconnect speedometer cable and necessary wiring connectors. Remove radio knobs and two retaining nuts. Remove instrument panel housing screws and remove panel. To install, reverse removal procedure.

GAUGES & SPEEDOMETER

Position shift lever in "L" and disconnect shift indicator cable from steering column. Carefully pry out trim plate. Remove gauge or speedometer retaining screws, disconnect speedometer cable and/or disconnect wire connectors. To install, reverse removal procedure.

PRINTED CIRCUIT

Remove speedometer or fuel gauge as previously outlined. Remove three screws and five light sockets to remove speedometer cluster printed circuit. Remove eight nuts, one or three resistors (as equipped), two screws and four light sockets to remove the tell-tail and fuel gauge cluster printed circuit. To install, reverse removal procedure.

APOLLO SERIES

INSTRUMENT PANEL & CLUSTER REMOVAL

Disconnect battery ground cable. Remove glove box. Remove upper air conditioner extension and lower outlet at center of panel; remove upper center outlet nozzle, adapter, and flex hose to right side outlet (if equipped). Remove panel pad nuts above glove box and ash tray; remove right side pad screw near pillar post. Remove upper carrier screws and left side carrier screw near left pillar post. Remove steering column cover, disconnect shift quadrant indicator cable at shift bowl (if automatic transmission). Remove steering column nuts at panel and lower carrier screws. Remove radio knobs, bezels and nuts. Remove two lower heater or air conditioner control

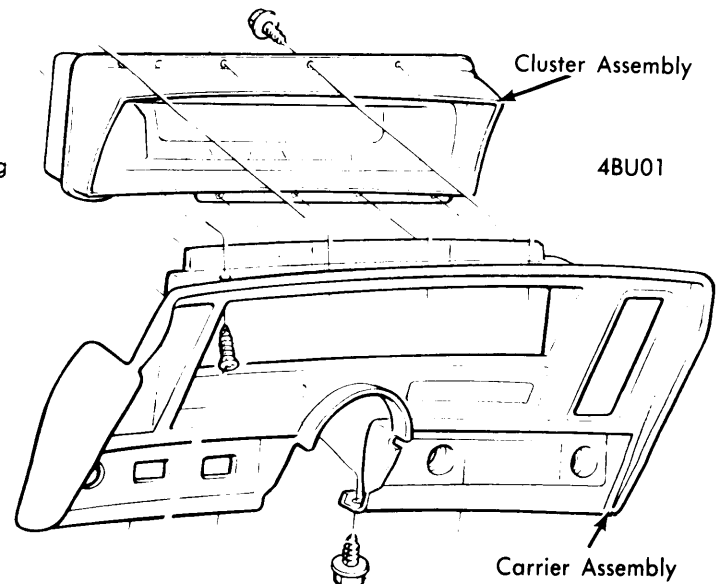

APOLLO INSTRUMENT PANEL

1974 BUICK (Cont.)

screws. Remove toe plate cover and toe plate-to-cowl screws and lower steering column. Disconnect speedometer cable and pull carrier assembly rearward. Separate cluster from carrier as required. To install, reverse removal procedure.

ELECTRA, ESTATE WAGON, LE SABRE, LIMITED & RIVIERA

INSTRUMENT PANEL & CLUSTER REMOVAL

Remove instrument panel lower filler and front speaker connector from radio. Remove glove box and door, and panel end screw. Remove six instrument panel cover retaining screws. Pull cover assembly loose from retainers and on the right side, the cover must be pulled downward while pulling rearward. To remove cluster housing continue as follows: Remove radio knobs, bezels and fader control if equipped; then remove trim plate and radio retaining nuts. Disconnect speedometer cable, shift quadrant, and necessary vacuum and electrical connectors. Remove cluster housing retaining screws and carefully lift housing outward. To install, reverse removal procedure.

GAUGES & SPEEDOMETER

Remove lower instrument filler panel. With shift lever in "L" position, disconnect shift indicator cable from steering column. Disconnect speedometer cable. Remove two instrument bezel screws and rotate bezel out of panel pulling top of face glass out first. Remove speedometer assembly screws and lift speedometer out. Remove fuel or temperature gauges as required. To install, reverse removal procedure.

PRINTED CIRCUIT

Remove fuel or temperature gauges as previously outlined. Insert a screwdriver into square hole at left top corner of panel front; rotate screwdriver and push connector back out of panel. Remove four nuts from front of circuit board panel and lift panel and printed circuit assembly out. To install, reverse removal procedure.

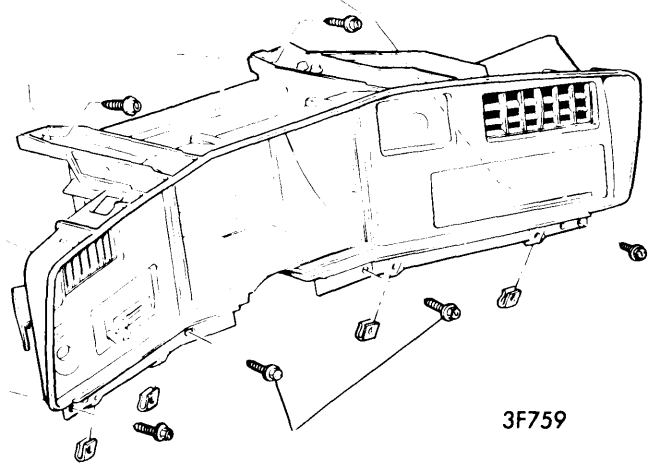

**ELECTRA, ESTATE WAGON, LE SABRE,
LIMITED & RIVIERA INSTRUMENT PANEL**